



National Défense
Defence nationale

B-GG-380-000/FP-002

CANADIAN ARMED FORCES DIVING MANUAL

VOLUME 2

ORGANIZATION, REGULATIONS, RULES AND COMPRESSED AIR BREATHING APPARATUS (CABA) DIVING

(ENGLISH)

(Supersedes B-GG-380-000/FP-002 dated 2015-12-01)

Issued on Authority of the Chief of the Defence Staff

OPI: D DIVE S 2

2016-08-09

Canada 



NOTICE

This documentation has been reviewed by the technical authority and does not contain controlled goods. Disclosure notices and handling instructions originally received with the document shall continue to apply.

AVIS

Cette documentation a été révisée par l'autorité technique et ne contient pas de marchandises contrôlées. Les avis de divulgation et les instructions de manutention reçus originellement doivent continuer de s'appliquer.

LIST OF EFFECTIVE PAGES

Insert latest changed pages and dispose of superseded pages in accordance with applicable orders.

NOTE

The portion of the text affected by the latest change is indicated by a black vertical line in the margin of the page. Changes to illustrations are indicated by miniature pointing hands or black vertical lines.

Dates of issue for original and changed pages are:

Original	0	2016-08-09	Ch	3
Ch	1		Ch	4
Ch	2		Ch	5

Zero in Change No. column indicates an original page. Total number of pages in this publication is 394 consisting of the following:

Page No.	Change No.	Page No.	Change No.
Title	0	4-1 to 4-50	0
A	0	5-1 to 5-64	0
i/ii to xiv	0	5A-1 to 5A-12	0
1-1 to 1-62	0	5B-1 to 5B-20	0
1A-1 to 1A-17/1A-18	0	6-1 to 6-18	0
1B-1 to 1B-7/1B-8	0	7-1 to 7-14	0
1C-1 to 1C-3/1C-4	0	8-1 to 8-5/8-6	0
2-1 to 2-30	0	8A-1 to 8A-14	0
3-1 to 3-31/3-32	0	8B-1 to 8B-4	0
3A-1 to 3A-19/3A-20	0		

Contact Officer: D DIVE S 2-2

© 2016 DND/MDN Canada

DIVING EMERGENCY MEDICAL ASSISTANCE & CONSULTATION

DIVING SUPERVISORS ARE TO ENSURE THEY ARE IN POSSESSION OF LOCAL DIVING EMERGENCY CONTACT PHONE NUMBERS (NEAREST EMERGENCY MEDICAL FACILITIES, RECOMPRESSION FACILITIES AND MEANS OF CASUALTY EVACUATION) AND A COMPLETE (AND BRIEFED) EMERGENCY EVACUATION PLAN PRIOR TO COMMENCING DIVING ACTIVITIES

NO RECOMPRESSION REQUIRED

Once immediate on-site actions have been carried out, initiate casualty transport.

911 and/or, follow dive team emergency evacuation plan to the nearest emergency medical facility.

RECOMPRESSION REQUIRED

Once immediate on-site actions have been carried out, initiate transport to nearest diving emergency medical facility (with available recompression chamber).

911 and/or follow dive team emergency evacuation plan, then call;

- PACIFIC DUTY DIVING MEDICAL OFFICER..... 1-250-888-0632**
- ATLANTIC DUTY DIVING MEDICAL OFFICER..... 1-902-721-8890**
- CENTRAL CONSULTANT OF DIVING MEDICINE (DRDC) 1-416-246-3155**

OTHER PERTINENT 24/7 EMERGENCY CONTACTS

JOINT RESCUE COORDINATION CENTERS

- PACIFIC 1-800-567-5111 / 250-413-8933 / Cell Phone # (pound) 727**
- CENTRAL..... 1-800-267-7270 / Cell Phone *(star) 16**
- ATLANTIC..... 1-800-565-1582 / 902-427-8200**

FLEET DIVING UNITS

- PACIFIC 250-363-2379**
- ATLANTIC 902-720-1339 (Daytime)**
..... 902-720-1353 (Evening)

DIVERS ALERT NETWORK (DAN) 24 HR Emergency Hotline 1-919-684-9111

FOREWORD

1. B-GG-380-000/FP-002, Canadian Armed Forces Diving Manual, Volume 2, Organization, Regulations, Rules and Compressed Air Breathing Apparatus (CABA) Diving, is issued by Director Diving Safety on authority of the Chief of the Defence Staff IAW DAODs 8009-0 and 8009-1.
2. This volume contains rules and regulations applicable to all forms of diving in the Canadian Armed Forces (CAF) and is the principal reference document governing the conduct of all CAF self-contained (air) diving. Other volumes of the CAF Diving Manual contain rules and regulations specifically applicable to the material within that Volume.
3. The CAF Diving Manual is comprised of the following volumes:
 - a. B-GG-380-000/FP-001, Canadian Armed Forces Diving Manual, Volume 1: History, Physics and Physiology of Diving,
 - b. B-GG-380-000/FP-002, Canadian Armed Forces Diving Manual, Volume 2: Organization, Regulations, Rules and Compressed Air Breathing Apparatus (CABA) Diving,
 - c. B-GG-380-000/FP-003, Canadian Armed Forces Diving Manual, Volume 3: Surface-Supplied Diving Manual,
 - d. B-GG-380-000/FP-004, Canadian Armed Forces Diving Manual, Volume 4: Self-Contained Mixed-Gas Diving:
 - (1) Book 1 of 3: Canadian Clearance Diving Apparatus Version 2 (CCDA [V2]),
 - (2) Book 2 of 3: Canadian Underwater Mine Countermeasures Apparatus Version 2 (CUMA [V2]), and
 - (3) Book 3 of 3: S-10 Oxygen Rebreather.
 - e. B-GG-380-000/FP-005, Canadian Armed Forces Diving Manual, Volume 5: Hyperbaric Chamber Operation and Treatment Procedures,
 - f. B-GG-380-000/FP-006, Canadian Armed Forces Diving Manual, Volume 6: Diving Supervisor's Handbook (English),
 - g. B-GG-380-000/FP-007, Manuel de Plongée dans les Forces Canadiennes, Volume 7 : Aide-Mémoire du Superviseur de Plongée (Français), and
 - h. B-GG-380-000/FP-008, Manuel de Plongée dans les Forces Canadiennes, Volume 8 : Organisation, Consignes, Règles et Appareil Respiratoire à Air Comprimé (ARAC).
4. The CAF Diving Manual is a controlled publication for issue solely to diving staff positions, diving teams and schools in support of their diving operations.
5. Suggestions for amendments shall be forwarded through the normal chain of command to National Defence Headquarters, Attention: Directorate of Diving Safety (D DIVE S).

TABLE OF CONTENTS

	PAGE
CHAPTER 1 – RULES AND REGULATIONS	1-1
GENERAL	1-1
101. Scope.....	1-1
102. Annexes and Index.....	1-1
DIVING RESPONSIBILITIES.....	1-1
103. Administration.....	1-1
104. Commanding Officer.....	1-2
105. Diving Officer.....	1-3
106. Diving Supervisor.....	1-3
107. Diver.....	1-4
108. Standby Diver.....	1-4
109. Diving Attendants (Tenders).....	1-5
110. Rescue Swimming.....	1-5
111. Divers on Loan.....	1-5
112. Allied Divers Diving with the CAF.....	1-5
SELECTION AND QUALIFICATION	1-7
113. General.....	1-7
114. Classification of Divers.....	1-7
115. Issue of Diving Equipment.....	1-7
116. Currency and Proficiency of Divers.....	1-7
117. Rescinding Qualifications.....	1-12
118. Non-diver Attendants.....	1-14
119. Re-qualification/Re-certification Requirements.....	1-14
SAFETY REGULATIONS	1-14
120. CABA Personal Required to Conduct Diving Operation.....	1-14
121. Free-swimming – General Rules.....	1-16
122. Free-Swimming – Clearance Divers.....	1-16
123. Depth Limitations.....	1-17
124. Lifelines, Float Diving, Marked Swimming and Marking of Lines.....	1-18
125. Buddy Lines.....	1-21
126. Safety Boats.....	1-21
127. Divers in Boats Underway.....	1-21
128. First-aid Equipment.....	1-21
129. Wearing of Knives.....	1-27
130. Meals and Alcohol.....	1-27
131. Dentures and Piercings.....	1-28
132. Contact Lens.....	1-28
133. Medications and Diving.....	1-28
134. Female Divers.....	1-28
135. Use of CAF Diving Equipment.....	1-28
136. Use of Non-CAF Diving Equipment.....	1-28
137. Buoyancy Compensator (BC).....	1-29
138. HP Air/Gas Cylinder Tests.....	1-29
139. Diving Equipment Maintenance.....	1-29
140. Purity of Compressed Breathing Air and Gases For Divers.....	1-30
141. Utilizing Diving Air From Non-CAF Sources.....	1-30
142. Hot/Warm Weather Diving Conditions.....	1-31

TABLE OF CONTENTS (Cont)

	PAGE
143. Cold Weather Diving Conditions.....	1-33
144. Contaminated Water Diving.....	1-36
145. Reduced Underwater Visibility.....	1-36
146. Pool Diving.....	1-36
DIVING SIGNALS	1-36
147. Warning Signals.....	1-36
148. Communications with Swimming Divers	1-39
149. Communications at the Dive Site	1-40
ADMINISTRATION AND MEDICAL RECORDS.....	1-42
150. Diving Administration.....	1-42
151. Diving Allowance	1-42
152. Medical, Dental and Physical Fitness Regulations.....	1-42
153. CF 849 Canadian Armed Forces Personal Diving Log	1-43
154. Canadian Armed Forces Diving Information Tracking System (CAFDITS).....	1-52
155. CF 377 Canadian Armed Forces Course Report	1-52
156. CF 777 Unsatisfactory Condition Report.....	1-52
157. Diving General Memoranda (DGM).....	1-52
158. Diving Technical Instruction (DTI)	1-52
159. Diving Supervisor’s No-D Log/Worksheet	1-53
160. Annual Diving Inspection	1-53
DIVING ACCIDENT AND INCIDENT REPORTS, GENERAL PROCEDURES	1-56
161. Necessity to Report	1-56
162. Incident Reporting.....	1-56
163. Accidents and Incidents.....	1-56
164. Reporting of Decompression Sickness and All Diving Accidents.....	1-56
165. Investigation of Life Support Equipment After a Diving Incident/Accident	1-57
166. Specific Action to be Taken Upon Recovery	1-58
INVESTIGATION OF SERIOUS DIVING ACCIDENTS.....	1-60
167. General	1-60
168. Initial Reporting.....	1-60
169. Formal Investigation	1-60
170. D Dive S Investigation	1-61
171. Documentation.....	1-61
Annex A1 – CAF Diving Incident and Accident – Report Forms.....	1A-1
Annex B1 – Definitions, Abbreviations and Acronyms.....	1B-1
Annex C1 – Orders and Reference Publications Pertaining to CABA Diving.....	1C-1
CHAPTER 2 – EMERGENCY PROCEDURES	2-1
GENERAL	2-1
201. Scope.....	2-1
MEDICAL EMERGENCIES.....	2-2
202. Immediate Action	2-2
203. Medical Emergency During a Dive	2-2
204. Treatment for Shock	2-3

TABLE OF CONTENTS (Cont)

	PAGE
205. Respiratory Emergencies	2-3
206. Post-traumatic Stress Disorder (PTSD)	2-4
SYMPTOMS AND TREATMENT OF RESPIRATORY DISORDERS	2-4
207. Hypoxia and Anoxia (O ₂ Deficiency)	2-4
208. Oxygen (O ₂) Toxicity.....	2-5
209. Carbon Dioxide (CO ₂) Toxicity	2-6
210. Carbon Monoxide (CO) Poisoning	2-7
211. Narcosis.....	2-7
DIVING EMERGENCIES WITH DIRECT MEDICAL INVOLVEMENT	2-8
212. Discussion	2-8
213. Drowning/Near-Drowning	2-8
214. Squeeze.....	2-9
215. Hypothermia	2-10
216. Hyperthermia	2-11
217. Gas Expansion	2-11
218. Blow-up.....	2-11
219. Fouling and Entrapment	2-12
220. Equipment Failure	2-12
221. Loss of Air Supply.....	2-12
222. Loss of Communication	2-13
223. Lost Diver.....	2-13
DIVING EMERGENCY PROCEDURES	2-14
MEDICAL EMERGENCIES REQUIRING RECOMPRESSION	2-18
224. General	2-18
225. Ancillary and Follow-up Treatment.....	2-18
226. Emergencies Requiring Recompression	2-19
227. Omitted Decompression and Arterial Gas Embolism, General	2-19
228. Omitted Decompression	2-20
229. Arterial Gas Embolism (AGE).....	2-20
230. Pneumothorax	2-21
231. Mediastinal Emphysema	2-22
232. Subcutaneous Emphysema.....	2-22
233. Decompression Sickness	2-22
234. Predisposing Factors For Decompression Sickness.....	2-22
235. Diagnosis of Decompression Sickness	2-22
236. Decompression Sickness – Mild (DCS Type I)	2-23
237. Decompression Sickness – Serious (DCS Type II).....	2-24
238. Rapid Neurological Examinations.....	2-25
RECOMPRESSION TREATMENT	2-27
239. General Procedure	2-27
240. Hyperbaric Chamber	2-28
241. Transporting the Patient	2-28
242. Treatment Tables	2-29
243. General Restrictions After Recompression Treatment.....	2-29
244. Hyperbaric Chambers – Other Uses	2-30

TABLE OF CONTENTS (Cont)

	PAGE
CHAPTER 3 – AIR DECOMPRESSION PROCEDURES AND TABLES.....	3-1
GENERAL	3-1
301. Introduction	3-1
302. Background.....	3-1
303. Air Decompression Tables Approved for Use with Compressed Air Breathing Apparatus (CABA)	3-2
304. Definition of Terms.....	3-4
305. Dive Recording	3-5
306. In-water Decompression.....	3-5
307. Failure to Decompress In-water	3-5
INSTRUCTIONS FOR THE USE OF CAF AIR DECOMPRESSION TABLES	3-5
308. Standard Air Decompression Table (CAF Air Diving Table 1) (Excerpt).....	3-5
309. Short Standard Air Decompression Table (CAF Air Diving Table 1S)	3-11
310. Repetitive Diving Table (CAF Air Diving Tables 4A and 4B).....	3-12
311. Depth Corrections for Diving at Altitude Table (CAF Air Diving Table 5)	3-25
312. Diving and Snorting Submarines	3-31/3-32
313. Flying After Diving.....	3-31/3-32
314. Hypobaric Chamber Duties	3-31/3-32
Annex A3 – Canadian Armed Forces Air Diving Tables (Metres)	3A-1
CHAPTER 4 – DIVING EQUIPMENT	4-1
DESCRIPTION AND OPERATING PROCEDURES, COMPRESSED AIR BREATHING APPARATUS (CABA) AND ACCESSORIES.....	4-1
401. Description	4-1
402. Endurance	4-2
403. Drysuits	4-6
404. Incompressible Drysuit	4-7
405. Pre-dive and Post-dive Checks, Maintenance, Repair and Replacement of CAF Incompressible Drysuits	4-9
406. Neoprene Drysuit.....	4-13
407. Drysuit Thermal Undergarments	4-14
408. Wetsuits	4-14
409. Wetsuit Maintenance and Stowage.....	4-15
410. Buoyancy Compensator, Black Diamond® Canadian Military Version (BDCMVBC)	4-15
411. Integral Diving Weights.....	4-19
412. HP Air Cylinders	4-20
413. Air Regulator.....	4-23
414. AGA MK II Full Facemask (FFM)/Regulator.....	4-26
415. Light-weight Surface-Supplied Diving Equipment (LWSSDE)	4-34
416. CABA/SAR TECH Rescue Diving Ensemble	4-41
417. CABA Maintenance	4-41
418. Diver's Half Mask.....	4-42
419. Submersible Pressure Gauge (SPG)	4-43
420. Diver's Day/Night Distress Flare.....	4-43
421. Diver's Lifeline Harness	4-43
422. Diving Knives	4-44
423. Swim Fins	4-44
424. Digital Depth Gauge	4-44
425. Compass.....	4-45

TABLE OF CONTENTS (Cont)

		PAGE
426.	Swim Board	4-45
427.	Diver's Watch.....	4-45
428.	Indicator Light	4-46
429.	Strobe Light	4-46
430.	Underwater Lighting	4-46
431.	Indicator Buoy.....	4-46
432.	Lost Diver Marker	4-46
433.	Diver Signal Recall	4-47
434.	Through-water Communications	4-47
435.	AGA MK II FFM/LWSSDE Communications	4-47
436.	Acoustic Pingers	4-48
	SUPPORT EQUIPMENT	4-48
437.	Diving Ladders.....	4-48
438.	Air Compressors	4-49
	CHAPTER 5 – STANDARD OPERATING PROCEDURES	5-1
	GENERAL DIVING PROCEDURES	5-1
501.	Introduction	5-1
502.	Dive Planning – General.....	5-1
503.	Dive Task Planning and Emergency Assistance.....	5-1
504.	Pre-dive Procedures.....	5-2
	GENERAL DIVING INSTRUCTIONS	5-6
505.	Caba Underwater Swimming Procedures	5-6
506.	LWSSDE SOPs	5-9
507.	Procedures for Diving on a Lifeline	5-19
508.	Working Around Corners or Inside Wrecks	5-19
509.	Current or Tideway	5-20
510.	Diving Limits and Hazards – Currents and Tidal Streams	5-20
511.	Water Inlet/Outlet Hazards	5-22
512.	Guidelines for Survivor Extraction from Overturned Vessels	5-25
513.	Ice Diving Standard Operating Procedures – CABA/LWSSDE.....	5-25
514.	Tools	5-25
515.	Lazy Shot Diving Procedures	5-25
	BOTTOM SEARCHES	5-31
516.	Introduction	5-31
517.	Lifeline Search.....	5-32
518.	Circular Search.....	5-32
519.	Towed-diver Search	5-35
520.	Light Jackstay Searches.....	5-37
521.	Snagline Search	5-42
522.	Grid Search.....	5-44
523.	Multiple Diver Seabed Search	5-46
524.	Lost Jackstay or Distance Line Procedure	5-48
525.	Hand-held Sonar Search	5-48
526.	Group Navigation Control System (GNCS) Group Swimming	5-48

TABLE OF CONTENTS (Cont)

	PAGE
UNDERWATER TOOLS AND WORK METHODS	5-49
527. U/W Lifting Tools	5-49
528. U/W Lifting	5-50
529. U/W Construction.....	5-52
530. U/W Timber and Wood Construction.....	5-52
531. Repairs to Military Floating Equipment.....	5-55
DIVING IN CONTAMINATED WATER	5-56
532. General	5-56
533. Microbial Hazards	5-60
534. Chemical Hazards	5-60
535. Contaminated Water Diving Equipment	5-61
536. Moderately Contaminated Water (MCW) Diving Procedures and Precautions	5-62
537. Post-dive Decontamination Procedures	5-63
538. Long-term Medical Precautions.....	5-64
Annex A5 – Guidelines for Survivor Extraction From Overturned Vessels.....	5A-1
Annex B5 – Ice Diving – Standard Operating Procedures – CABA/LWSSDE	5B-1
CHAPTER 6 – STANDARD OPERATING PROCEDURES – SHIP’S DIVING	6-1
GENERAL	6-1
601. Introduction	6-1
DIVING ON OR NEAR A SHIP’S BOTTOM	6-1
602. Diving Operation Requirements	6-1
603. Diving Operations on Foreign Vessels by CAF Divers.....	6-8
SHIP’S DIVERS DIVING SEARCHES.....	6-8
604. General	6-8
605. Ship’s Bottom Searches	6-9
606. Free Area Aft Searches	6-9
607. Search Scheme “A” – Necklace Search	6-9
608. Modified Search Scheme “A” – Half-necklace Search	6-12
609. Search Scheme “B” – Zig-zag Search.....	6-12
610. Search Scheme “C” – Ladder Search	6-15
611. Emergency Stations	6-17
612. Limpet Mine Disposal Equipment.....	6-17
SUBMARINE SHIP’S DIVER	6-17
613. General	6-17
614. Blanking Plates	6-17
615. Bow Cap Seals	6-18
616. Velocimeter.....	6-18
617. Underwater Telephone	6-18
618. Torpedo Tube Test Doors	6-18
619. Decompression in Snorting Submarines	6-18
AIRCRAFT RESCUE AND RECOVERY	6-18
620. General	6-18

TABLE OF CONTENTS (Cont)

	PAGE
CHAPTER 7 – COMBAT DIVING	7-1
701. Overview	7-1
702. The Role of the Combat Diver	7-1
703. Tasks	7-1
704. Key Army Diving Appointments	7-3
705. Unit Diving Organization	7-3
706. Employing Combat Divers	7-5
707. Principles of Combat Diver Employment	7-6
708. Combat Diving Safety	7-6
709. Group Navigation Control System (GNCS)	7-7
710. Combat Diver Training	7-10
711. Candidate Selection and Evaluation	7-10
712. Conduct of Combat Diver and Combat Diving Supervisor's Course	7-11
713. Maintaining Currency and Proficiency	7-12
714. Unit Diving Team Training	7-14
715. Collective Training Exercises	7-14
716. Training with Allied Diving Teams	7-14
CHAPTER 8 – STANDARD OPERATING PROCEDURES SEARCH AND RESCUE	8-1
GENERAL	8-1
801. Definitions	8-1
802. General Diving Regulations	8-1
SAR DIVING REGULATIONS	8-1
803. SAR Diving Operations	8-1
804. Rescue Diving Operations	8-1
805. Non-rescue Diving Operations	8-2
806. CABA Rescue and CSRD Diving Operations, SAR	8-2
807. Confined Space Rescue Diving Procedures	8-3
808. SAR Tech Safe Training Practices	8-3
809. Currency Requirements, SAR	8-5/8-6
810. SAR Tech Rental of Non-service Diving Equipment	8-5/8-6
Annex A8 – Confined Space Rescue Diving for Survivor Extraction	8A-1
Annex B8 – Safe Training Practices for Confined Space Rescue Diving (CSRD) Training	8B-1

LIST OF FIGURES

FIGURE	TITLE	PAGE
1-1	Diver Qualifications, Equipment Operating Limits and Supervisory Limits (4 Sheets)	1-8
1-2	Diving Lines and Shots	1-19
1-3	Marking of Lines	1-20
1-4	CAFDTMK Contents (4 Sheets).....	1-22
1-5	Buddy Line	1-26
1-6	Knife Mounting Locations.....	1-27
1-7	Thermal Hydration Table.....	1-32
1-8	Thermal Factors Affecting Divers.....	1-34
1-9	Wind Chill Index Chart	1-35
1-10	Diving Warning Signals (DAY)	1-38
1-11	Diving Warning Signals (Small Craft, NIGHT)	1-39
1-12	Manual Line Signals/Hand and Special Signals for Diving	1-41
1-13	Procedures and Abbreviations, CF 849 (CAF Personal Diving Log) (2 Sheets)	1-44
1-14	Sample CF 849 (CAF Personal Diving Log) (6 Sheets)	1-46
1-15	Diving Supervisor's No-D Log/Worksheet (<i>to be reproduced locally</i>).....	1-55
1A-1	CAF Diving Incident/Accident Report No. 0	1A-4
1A-2	CAF Diving Incident/Accident Report No. 1	1A-5
1A-3	CAF Diving Incident/Accident Report No. 2	1A-6
1A-4	CAF Diving Incident/Accident Report No. 3 (3 Sheets)	1A-7
1A-5	CAF Diving Incident/Accident Report No. 4 (2 Sheets)	1A-10
1A-6	CAF Diving Incident/Accident Report No. 5 (4 Sheets)	1A-12
1A-7	CAF Diving Incident/Accident Report No. 6.....	1A-16
1A-8	CAF Diving Incident/Accident Report No. 7	1A-17/1A-18
2-1	Diving Emergency Procedures (3 Sheets).....	2-15
2-2	Rapid Neurological Examination	2-26
2-3	Restrictions on Diving or Flying After Recompression Treatment	2-28
3-1	Air Diving Limits	3-3
3-2	Standard Air Decompression Dive Profile, 31 msw/22 min (ref. Article 308, paragraph 8, Example 1).....	3-8
3-3	Dive Record Chart (Metres): Standard Air Decompression Dive, 31 msw/22 min (ref. Article 308, paragraph 8, Example 1)	3-9
3-4	Dive Record Chart (Metres)	3-10
3-5	Repetitive Diving Worksheet (Metres)	3-17
3-6	CAF Air Diving Tables Repetitive Diving Flowchart.....	3-24
3-7	Altitude Diving Worksheet (Metres)	3-30
3A-1	CAF Air Diving Table 1 (Metres) – Standard Air Decompression Table (15 Sheets).....	3A-2
3A-2	CAF Air Diving Table 1S (Metres) – Short Standard Air Decompression Table.....	3A-17
3A-3	CAF Air Diving Table 4 (Metres) – Repetitive Diving Table.....	3A-18
3A-4	CAF Air Diving Table 5 (Metres) – Depth Corrections for Diving at Altitude Table	3A-19/3A-20
4-1	CABA Endurance Graphic	4-4
4-2	CABA Reserve with CABA Endurance Chart	4-5

LIST OF FIGURES (Cont)

FIGURE	TITLE	PAGE
4-3	CAF Incompressible Drysuit 1 st – Line Maintenance – Pre-dive Check	4-9
4-4	CAF Incompressible Drysuit 1 st – Line Maintenance – Post-dive Check.....	4-10
4-5	CAF Incompressible Drysuit 1 st – Line Maintenance – Repairs	4-10
4-6	CAF Incompressible Drysuit 2 nd – Line Maintenance	4-11
4-7	CAF Incompressible Drysuit 3 rd – Line Maintenance.....	4-12
4-8	CAF Incompressible Drysuit Replacement Policy	4-13
4-9	BDCMVBC	4-17
4-10	Loading Options, Integral BDCMVBC Weight Pouches	4-20
4-11	CABA Cylinder Recharging Procedure	4-22
4-12	Regulator Post-dive Cleaning and Storage (2 Sheets).....	4-24
4-13	AGA Divator MK II FFM	4-27
4-14	Changing From FFM to Half Mask (Regulator) Configuration	4-28
4-15	AGA MK II FFM Disassembly	4-32
4-16	AGA MK II FFM Exhalation Assembly	4-33
4-17	LWSSDE Console, Yokes and HP Hose Whips, Comms and Umbilicals	4-35
4-18	LWSSACP (Diver's Console).....	4-37
4-19	SBA, HP and IP Hose Whips – Redundant Second Stage.....	4-38
4-20	Rigging for LWSSDE Diving	4-40
4-21	U/W Compass (Example).....	4-45
4-22	AGA MK II FFM w/Comms.....	4-48
4-23	4-49
5-1	CAF Diving Emergency Planning and Task Definition Grid.....	5-5
5-2	CABA Checklist.....	5-7
5-3	Diving Supervisor's Checklist (CABA/LWSSDE)	5-8
5-4	LWSSDE Diving Sequence of Operations Checklist (4 Sheets).....	5-10
5-5	SOPs for LWSSDE Diving Checklist (3 Sheets).....	5-14
5-6	LWSSDE Post-dive Checklist	5-17
5-7	LWSSDE Over-bottom Air Supply Pressure Adjustment (msw/bar).....	5-18
5-8	Recommended Current Limits	5-21
5-9	CAF Diving Safety Equipment Requirements – Dive Sites and Diving Safety Boats	5-24
5-10	Supplementary Decompression/Lazy Shot Signals.....	5-26
5-11	Required Equipment for Lazy Shot Diving	5-27
5-12	CABA Lazy Shot Diving, General Arrangement	5-30
5-13	Lifeline Search	5-32
5-14	Circular Search	5-34
5-15	Code for Passing Signals by Marker Floatline in a Towed-diver Search.....	5-36
5-16	Towed-diver Search	5-36
5-17	Light Jackstay Components Mounted on an Inflatable Boat.....	5-40

LIST OF FIGURES (Cont)

FIGURE	TITLE	PAGE
5-18	Riser Assembly, Light Jackstay	5-41
5-19	Snagline Search	5-43
5-20	Grid Search	5-45
5-21	Multiple Diver Seabed Search.....	5-47
5-22	Improvised Lifting Aid Using an Oil Drum	5-51
5-23	Methods of Securing a Timber Patch.....	5-53
5-24	Timber Patch.....	5-54
5-25	Table for Assessing the Possibility of Exposure to Contaminants in Dive Site Waters (3 Sheets)	5-57
5A-1	Additional Equipment Required for Capsized Vessel/Confined Space Operations.....	5A-5
5B-1	Ice Diving Site	5B-3
5B-2	Ice Diving Hole	5B-3
5B-3	Dive Set-up, Ice Diving.....	5B-4
5B-4	Two Single 2265-Litre (80-Cubic Foot) Cylinders Rigged for CABA Ice Diving with Mini Gauge	5B-7
5B-5	CABA Ice Diving Configuration	5B-8
5B-6	CABA Ice Diving Side Block Assembly.....	5B-9
5B-7	CABA Ice Diving Side Block Assembly.....	5B-10
5B-8	Example of Octopus Regulator Marked for Ice Diving.....	5B-11
5B-9	Ice Diving Equipment Checklist (3 Sheets).....	5B-18
6-1	Diving Safety Checklist	6-4
6-2	Diving Safety Checklist	6-5
6-3	NATO Safe-to-dive Certificate (2 Sheets).....	6-6
6-4	Search Scheme “A” – Necklace Search	6-11
6-5	Search Scheme “B” – Zig-zag Search	6-14
6-6	Search Scheme “C” – Ladder Search.....	6-16
7-1	Combat Diving Tasks	7-2
7-2	Combat Engineer Regiment (31 Divers)	7-4
7-3	Engineer Support Regiment (22 Divers)	7-4
7-4	Group Navigation Control System (GNCS).....	7-9
7-5	Table of Criteria and Procedures to Follow for Combat Divers Regaining Diving Currency/Qualification	7-13

CHAPTER 1
RULES AND REGULATIONS
GENERAL

101. SCOPE

1. This Chapter contains the regulations governing the conduct of CAF diving operations and exercises. These regulations, which have evolved from long diving experience, are applicable to all CAF diving personnel and to civilian divers employed by the Department of National Defence (DND).
2. These regulations are mandatory and are intended to ensure both the safety of the diver and the efficiency of diving operations. In emergencies or operations during hostilities, and during training for specific hazardous missions, calculated risks may have to be taken. Commanding Officers will have to weigh these risks against the consequence of failure to complete the task. Commanding Officers are to ensure that only justifiable deviations from these regulations are permitted.
3. All personnel concerned with diving shall make themselves thoroughly conversant with these regulations, strict compliance with which is essential to ensuring the safety of the diver. Each Article of this manual shall be read in its entirety, in order for the full context to be understood. Many Articles must be read in conjunction with other Articles or Sections, in order for their full context to be understood. Portions of text within Articles are not to be read or applied selectively.
4. The successful completion of a diving operation is dependent on careful attention to detail. Investigation of diving accidents has shown that the diver or Supervisor who habitually ignores details will eventually come to grief.
5. Local Standard Operating Procedures should be developed for particular types of diving operations that are carried out repeatedly. Refer to [Chapters 5, 6, 7 and 8](#) for additional guidance.

102. ANNEXES AND INDEX

1. Definitions, abbreviations and acronyms applicable to diving in the CAF are found at Chapter 1, [Annex B1](#). These must be read in conjunction with the respective articles.
2. Additional orders and references pertaining to CAF diving are found at Chapter 1, [Annex C1](#).
3. An Alphabetical Index may be found at the back of this Volume.

DIVING RESPONSIBILITIES

103. ADMINISTRATION

1. CAF Diving DAODs prescribes the organization, authorities and responsibilities related to all diving matters within Units, Formations and National Defence Headquarters (NDHQ).
2. **CAF Diving OPIs and OCIs**
 - a. Directorate of Diving Safety (D DIVE S) is an NDHQ Directorate and is the diving safety regulatory authority. D DIVE S issues the Diving Manuals and DGMs under authority of the CDS. D DIVE S is the office of prime interest (OPI) for:
 - (1) All CAF diving policy; D DIVE S also chairs the CAF Diving Policy Committee which ensures that all matters concerning CAF diving are addressed in a common forum and that CAF diving policy is supported as necessary by the relevant OPIs and OCIs listed in the article.

- (2) CAF diving safety policy, including manuals and training procedures,
- (3) Safety inspections of all CAF Diving Teams and Units, and
- (4) Investigation of diving incidents/accidents.

- b. OPI for naval diving policy Naval Fleet Requirement (NFR)
- c. OPI for Search and Rescue (SAR) Technicians 1 CAD HQ/Staff Officer SAR Technicians (SO SAR Tech)
- d. OPI for Combat Divers Commandant CAF School of Military Engineering
- e. OPI for Port Inspection Divers (PID) Commander Naval Reserve Headquarters (NAVRES HQ)
- f. Within NDHQ, OPI/ design authority for CAF diving systems and equipment Director Naval Platforms and Systems (DNPS)
- g. Within NDHQ, OPI for diving equipment requirements Director Naval Requirements (DNR)
- h. Within NDHQ, OPI for CAF Diving Medical Standards and Policy C Navy RCN Surgeon
- i. OPI for CAF Diving Medicine CDHM at DRDC – Toronto

3. Fleet Diving Units (Atlantic and Pacific) are responsible for the training of Clearance, Combat, SAR, Ship's and Port Inspection divers and divers of CANSOFCOM, as outlined in CAF Diving DAODs.

4. The operational units will follow the normal chain of command. The Formation OPIs are Senior Staff Officer Diving and Mine Warfare in MARLANT and Commanding Officer Fleet Diving Unit (Pacific), the SO SAR Tech 1 Canadian Air Division Winnipeg and the Senior Army Diver at the Army Dive Centre, CFB Gaagetown. The Commander Naval Reserve Headquarters (NAVRES HQ) is the OCI for Port Inspection Divers (PID).

104. COMMANDING OFFICER

1. The Commanding Officer shall ensure that time and resources are made available for the proper training and exercise of all divers under his or her command. The CO may delegate authority for the detailed administration of diving matters and the conduct of diving operations to subordinate officers, but such delegation shall in no way relieve the CO of overall responsibility for the safety, well-being and efficiency of diving personnel.

2. The member delegated by the CO to be the Diving Officer should be selected from those members with an appropriate qualification as listed below (refer also to [Figure 1-1](#)):

- a. Clearance Diving Officer (CLDO),
- b. Clearance Diver (CD) QL 5B or above,
- c. Ship's Team Diving Officer (STDO),
- d. Ship's Team Diving Supervisor (STDS),
- e. Combat Diving Officer (CBTO),

- f. Combat Diving Supervisor (CBTS),
- g. SAR Technician Diving Supervisor (SARS) (for SAR diving only),
- h. Port Inspection Diver (PID QL 4), and
- i. Port Inspection Diver (PID QL 3).

3. If no officer with a diving qualification is borne then an appropriate alternate may be delegated as laid down in [Article 106](#).

105. DIVING OFFICER

1. The Diving Officer is responsible to the Commanding Officer for :
 - a. The proficiency of all diving personnel on the team,
 - b. The organization and preparation of all diving operations carried out under the Diving Officer's direction,
 - c. Scheduling of exercises and training for personnel in order to maintain proficiency,
 - d. Maintenance of all diving records,
 - e. Scheduling the maintenance of diving equipment in accordance with current technical instructions, and
 - f. Briefing the Diving Supervisor(s).

106. DIVING SUPERVISOR

1. All diving operations shall be carried out under the direct supervision of a fully qualified and current Diving Supervisor who is trained in the equipment being used (see [Figure 1-1](#)), except as described at [paragraph 3](#).
2. The Diving Supervisor shall be in full charge of the diving team. The Diving Supervisor must be continuously at the scene of the diving operation and must not enter the water or hyperbaric chamber unless properly relieved by another qualified Supervisor.
3. Where none of the supervisory personnel listed in [Figure 1-1](#) are available, only emergency diving operations may be conducted. They shall be carried out under the supervision of the Commanding Officer or an officer delegated in writing. The advice of the most experienced diver present should be heeded.
4. The Diving Supervisor is to be fully conversant with the objectives and requirements of the task undertaken. The Diving Supervisor is responsible for ensuring
 - a. The safety of all members of the diving team,
 - b. That at least the minimum permitted number of qualified divers as laid down in [Article 120](#) are present at the site for the duration of the tasks,
 - c. That each member of the team is fully briefed on the objectives and requirements of the task,
 - d. That the diving operation is conducted in strict compliance with diving regulations,
 - e. That an accurate record of every dive is maintained,
 - f. Equipment is authorized and up-to-date, and
 - g. Personal dive logs are current with regards to medical, dental examination, physical fitness and dive currencies.

5. Commanding Officer may authorize in writing a medically unfit and no longer current dive supervisor, provided that the supervisor is proficient in the equipment supervised and that their medical condition does not prevent them from carrying out their duties. This authorization shall be reviewed and annotated on the commanding officers review page annually.

107. DIVER

1. In order to carry out diving duties successfully and safely, every diver shall maintain a high standard of physical fitness IAW current CAF Diving DAODs.

2. If a diver becomes ill the diver shall report to a Medical Officer, shall inform the Diving Officer and shall not dive until medically cleared to do so.

3. [Article 116](#) gives a detailed explanation of the level of proficiency/currency required of each diver. All CAF divers dive only as a part of a CAF diving team, unless under instruction. Divers are not to be considered self-contained operators capable of being reassigned into teams at short notice, since the safety of each diver is enabled through the stability and integrity of each CAF team. For example, the Diving Officer and Supervisor must know the status, capability and any limitations of each team member when planning and executing every dive. Divers on loan are an exception to this Article, as dealt with at [Article 111](#).

4. All techniques and procedures utilized by individual divers have been developed within the concept of a CAF diving team. The CAF diving team is the basic organizational element upon which safe and effective diving relies. Accordingly, CAF divers are to be exercised and operated as team members, since they are neither trained nor equipped to be deployed as self-sufficient individuals. Refer to [Article 111](#) concerning divers on loan, which is to be the exception rather than the rule in CAF diving.

108. STANDBY DIVER

1. Whenever diving operations are in progress a standby diver is required at the surface at a specified state of readiness. Standby diver equipment shall be prepared and tested before any diving takes place. Diving Officers and Supervisors will not appoint standby divers who are unfit for diving.

2. The Diving Supervisor specifies the required state of readiness of the standby diver. There are two states of Standby Diver readiness:

- a. **Immediate Notice.** Diver is fully dressed and ready for the water with the exception of the facemask/mouthpiece and
- b. **Ready.** Diver is fully dressed with the exception of fins, air cylinder(s) and facemask/mouthpiece, all of which must be within reach.

3. The standby diver shall be:

- a. Current and in-date (refer to [Article 116](#)),
- b. Equipped with a redundant second stage regulator and
- c. Qualified to the maximum depth anticipated for each specific task.

4. The standby diver is always to dive on a lifeline as an "attended diver".

5. The standby diver is to be at IMMEDIATE NOTICE in the following circumstances:

- a. When diving under hazardous conditions, e.g. ice diving, wreck diving, at night or during restricted visibility,
- b. When tidal streams or currents are stronger than 0.5 knots (for Combat Divers, also refer to [Chapter 7](#)),

- c. When free-swimming is taking place IAW [Articles 121](#) and [122](#),
- d. Whenever the Diving Supervisor considers it likely that the diver may require assistance,
- e. During all initial diver training, and
- f. When diving operations exceed 30 msw in depth.

109. DIVING ATTENDANTS (TENDERS)

- 1. When diving with LWSSDE or swimming in CABA equipment on a lifeline, it is preferable that the diver be tended physically or visually by a diver who is qualified and current in the apparatus being used. An attendant continuously keeps in hand the diver's lifeline or umbilical or continuously watches the diver's float or marker.
- 2. [Article 507](#) outlines the attendant's duties when diving on a lifeline.
- 3. In diving training units, personnel under instruction may act as attendants.

110. RESCUE SWIMMING

- 1. CAF divers may be required to perform Rescue Swimmer duties. Rescue Swimmers may be deployed from ships, small boats and aircraft to render assistance to personnel in the water (e.g. man overboard or downed aircraft).
- 2. The Rescue Swimmer:
 - a. Shall be instructed in the performance of required duties and fully understand them,
 - b. Should be a strong swimmer and highly motivated,
 - c. Shall be positively buoyant wearing a wetsuit, dry suit, or rescue swimmer suit. In tropical waters if no suit is worn, a life vest shall be worn,
 - d. Shall be highly visible (an indicating light shall be worn at night and international orange hood may be worn by day), and
 - e. Shall carry a quick-release safety knife.

111. DIVERS ON LOAN

- 1. When divers are loaned between teams, units or ships, the loaning Diving Officer/Supervisor is responsible for ensuring that the diver is in all respects qualified and fit to carry out the tasks for which the diver is being loaned and that any equipment taken by the diver is in proper working order.
- 2. The gaining unit is to fully inform the loaning unit as to the nature of the task the diver is to perform and is fully responsible for the safety of the diver during the period of the loan.
- 3. Instructions for the recording of a loaned diver's activity are set out in [Article 154](#).

112. ALLIED DIVERS DIVING WITH THE CAF

- 1. In order for military divers from allied nations to dive with the CAF, under CAF regulations and in CAF diving equipment, specific preparations and authorization are required. Such diving enables exchange of information for identified and agreed military objectives and in some cases will permit allied personnel to retain their foreign diving qualification while serving in Canada.

- a. This Article does not apply to experimental diving at EDU or to foreign military personal posted to specific CAF diving organizational positions under the military Personnel Exchange Program, who serve and dive under terms of reference set out in formal exchange agreements.
2. Because of the numerous variants of diving systems among allied nations, it is essential to safety that qualified foreign military divers be formally familiarized in CAF diving equipment and procedures prior to diving.
3. CAF divers shall supervise such dives and fill all essential diving team positions IAW the applicable Article and Volume of the Diving Manual on Minimum Personnel Requirements. Allied divers shall act only as divers and general assistants.
4. The CO of any CAF diving team may request to host and conduct allied dives IAW the requirements below. Formation authorization to proceed shall only be granted after the following has been completed:
 - a. The CO of the host unit must have received written authorization from the CO of the allied Unit, Team or individual divers involved, permitting them to dive under CAF regulations using CAF diving equipment, including the following information:
 - b. Reason for the request, e.g. information exchange, qualification maintenance or duty,
 - c. Confirmation that the divers are considered to be on duty while conducting such allied dives,
 - d. Participant information including:
 - (1) Full service identification info,
 - (2) Equipment qualifications,
 - (3) Level and type of diving qualification, and
 - (4) Confirmation of medical fitness to dive and currency.
5. The host Unit CO shall provide the following additional details when seeking formation authorization to proceed:
 - a. The type of CAF equipment to be used – based on comparability to allied military equipment identified at [paragraph 4.d.](#);
 - b. The type of diving to be conducted – based on comparability to level of training and qualifications identified at [paragraph 4.d.](#);
 - c. Identification of diving equipment and procedural differences having a safety impact and how these will be mitigated;
 - d. An outline of the formal familiarisation package intended, and
 - e. Start and end dates for which authorization is sought.
6. Where practical, existing CAF diving training documentation should be used as the basis for the formal familiarisation package.
7. All formal familiarisation training must be conducted in a controlled environment such as classroom for dry training and a pool or camber for wet training.
8. All dives conducted under this article shall be entered in the allied diver's logbook and annotated as a "CAF Dive".

9. Brief details of the formal familiarisation package details shall also be entered in the allied diver's logbook, with reference to the documentation raised at [paragraphs 4](#) and [5](#).

10. Copies of all documentation are to be kept on local files at the host unit, the authorizing formation and also may be provided to the allied divers as required by them.

SELECTION AND QUALIFICATION

113. GENERAL

Care must be taken in the selection and recommendation of suitable volunteer candidates. Divers underwater and on the surface are subject to many hazards. Because they may work alone or in pairs, they must have self-confidence and a strong sense of responsibility. They must be capable, reliable, demonstrate a high degree of professionalism, and must maintain the CAF standard of physical fitness.

114. CLASSIFICATION OF DIVERS

Full details and selection, qualifications and conditions of service are contained in Command Orders A-PD-055-001/AG-001. Any additional information required, such as particulars of syllabi, can be obtained by contacting the Commanding Officers of FDU(A), FDU(P) and CAFSME.

115. ISSUE OF DIVING EQUIPMENT

1. On successful completion of the appropriate qualification course the diver shall be issued diving equipment IAW CAF Scale D01-312.

2. Diving team equipment and entitlements are listed in CAF Equipment Checklists (ECLs) available on the DIN.

116. CURRENCY AND PROFICIENCY OF DIVERS

1. The importance of regular exercise for divers cannot be over-emphasised. Unpracticed divers are a danger to themselves and to others. CABA divers CoC must ensure that their divers are provided with every opportunity to exercise underwater as frequently as conditions will allow.

2. CAF divers must dive every 90 days to remain current.

3. To be considered proficient in CABA, a diver must conduct a minimum of one dive and participate in at least six dive cycles during the 90-day period.

4. When more than one cycle is conducted in one day for the purposes of proficiency training, it is required that team personnel rotate throughout various positions in each diving cycle to maximize the training and proficiency benefit. All units are encouraged to maximize diver in-water time.

5. Pool diving for currency or proficiency is detailed at [Article 146](#).

6. The attention of officers in charge of diving teams is directed to their operational commander's orders on level of practice and proficiency required of their divers and diving teams. These may set standards that exceed the minimum level.

7. For a diving team to be considered worked up, all dive team members must complete dives practicing their underwater skill sets or dive supervisor duties on a regular basis.

8. For CLDvrs a check dive must be conducted when currency requirement above are not met.

9. For CBTDvrs currency requirements refer to Chapter 7, [Figure 7-5](#).

Qualification	Code	Eqpt	Diving Limits	Supervisory Limits
Clearance Diving Officer	ADFR	CABA	Maximum authorized depth 30 msw (working dives) 45 msw (inspections dives only) refer to note 6	Maximum authorized depth of equipment
Clearance Diving Officer	ADFR	LWSSDE	Maximum authorized depth of equipment	Maximum authorized depth of equipment
Clearance Diver PO1 and above	AIUK	CABA	Maximum authorized depth 30 msw (working dives) 45 msw (inspection dives only) refer to note 6	Maximum authorized depth of equipment
Clearance Diver PO1 and above	AIUK	LWSSDE	Maximum authorized depth of equipment	Maximum authorized depth of equipment
Clearance Diver PO2 QL6B	AIUL	CABA	Maximum authorized depth 30 msw (working dives) 45 msw (inspection dives only) refer to note 6	Maximum authorized depth of equipment
Clearance Diver PO2 QL6B	AIUL	LWSSDE	Maximum authorized depth of equipment	Maximum authorized depth of equipment
Clearance Diver PO2	AIUK	CABA	Maximum authorized depth 30 msw (working dives) 45 msw (inspection dives only) refer to note 6	45 msw (refer to Note 3)
Clearance Diver PO2	AIUK	LWSSDE	Maximum authorized depth of equipment	45 msw (refer to Note 3)
NOTES				
<ol style="list-style-type: none"> 1. No-decompression dives only. 2. CO's authorization required for dives deeper than 15 msw. 3. For depth exceptions refer to Article 123. 4. Special Ops Swimmers commence diving training in CABA but complete their O₂ Swimmer qualifications IAW Volume 4 and are not CABA qualified. 5. Will have same supervision authority as QL4 on promotion to PO 2. 6. CO's authorization required for working dives deeper than 30 msw. 				

Figure 1-1 (Sheet 1 of 4) Diver Qualifications, Equipment Operating Limits and Supervisory Limits

Qualification	Code	Eqpt	Diving Limits	Supervisory Limits
Clearance Diver MS	AIUK	CABA	Maximum authorized depth 30 msw (working dives) 45 msw (inspection dives only) refer to note 6	30 msw (refer to Notes 1 and 3)
Clearance Diver MS	AIUK	LWSSDE	Maximum authorized depth of equipment	30 msw (refer to Notes 1 and 3)
Clearance Diver LS QL5B	AIUK	CABA	Maximum authorized depth 30 msw (working dives) 45 msw (inspection dives only) refer to note 6	CABA/LWSSDE 30 msw (refer to Notes 1 and 3)
Clearance Diver LS QL5B	AIUK	LWSSDE	Maximum authorized depth of equipment	CABA/LWSSDE 30 msw (refer to Notes 1 and 3)
Clearance Diver AB – LS QL5A	AIUJ	CABA	Maximum authorized depth 30 msw (working dives) 45 msw (inspection dives only) refer to note 6	NIL
Clearance Diver AB – LS QL5A	AIUJ	LWSSDE	Maximum authorized depth of equipment	NIL
Port Inspection Diver QL4	05668	CABA	Maximum authorized depth 30 msw (working dives) 45 msw (inspection dives only) refer to note 6 (refer to Note 3)	45 msw (refer to Note 3)
NOTES				
<ol style="list-style-type: none"> 1. No-decompression dives only. 2. CO's authorization required for dives deeper than 15 msw. 3. For depth exceptions refer to Article 123. 4. Special Ops Swimmers commence diving training in CABA but complete their O₂ Swimmer qualifications IAW Volume 4 and are not CABA qualified. 5. Will have same supervision authority as QL4 on promotion to PO 2. 6. CO's authorization required for working dives deeper than 30 msw. 				

Figure 1-1 (Sheet 2 of 4) Diver Qualifications, Equipment Operating Limits and Supervisory Limits

Qualification	Code	Eqpt	Diving Limits	Supervisory Limits
Port Inspection Diver QL4	05668	LWSSDE	45 msw (refer to Note 3)	45 msw (refer to Note 3)
Port Inspection Diver QL3	00496	CABA	Maximum authorized depth 30 msw (working dives) 45 msw (inspection dives only) refer to note 6 (refer to Notes 3 and 5)	30 msw (refer to Notes 1 and 3)
Port Inspection Diver QL3	00496	LWSSDE	45 msw (refer to Notes 3 and 5)	30 msw (refer to Notes 1 and 3)
Port Inspection Diver QL2	00494	CABA	Maximum authorized depth 30 msw (working dives) 45 msw (inspection dives only) refer to note 6 (refer to Note 3)	NIL
Port Inspection Diver QL2	00494	LWSSDE	45 msw (refer to Note 3)	NIL
Combat Diving Officer	ADUV	CABA/ LWSSDE	30 msw (refer to Notes 1 and 2)	30 msw (refer to Notes 1 and 2)
Combat Diving Supervisor	AHNX	CABA/ LWSSDE	30 msw (refer to Notes 1 and 2)	30 msw (refer to Notes 1 and 2)
Combat Diver	AFEP	CABA/ LWSSDE	30 msw (refer to Notes 1 and 2)	NIL

NOTES

1. No-decompression dives only.
2. CO's authorization required for dives deeper than 15 msw.
3. For depth exceptions refer to [Article 123](#).
4. Special Ops Swimmers commence diving training in CABA but complete their O₂ Swimmer qualifications IAW Volume 4 and are not CABA qualified.
5. Will have same supervision authority as QL4 on promotion to PO 2.
6. CO's authorization required for working dives deeper than 30 msw.

Figure 1-1 (Sheet 3 of 4) Diver Qualifications, Equipment Operating Limits and Supervisory Limits

Qualification	Code	Eqpt	Diving Limits	Supervisory Limits
SAR Tech QL5A	AAHX	CABA	30 msw (refer to Notes 1 and 2)	NIL
SAR Tech Diving Supervisor	AFHD	CABA	30 msw (refer to Notes 1 and 2)	30 msw (refer to Notes 1 and 2)
Ship's Team Diving Officer	AEJF	CABA	30 msw (refer to Notes 1 and 2)	30 msw (refer to Notes 1 and 2)
Ship's Team Diving Supervisor	AHCV	CABA	30 msw (refer to Notes 1 and 2)	30 msw (refer to Notes 1 and 2)
Ship's Team Diver	AHCU	CABA	30 msw (refer to Notes 1 and 2)	NIL
Reserve Ship's Team Diving Officer	TBP	CABA	30 msw (refer to Notes 1 and 2)	30 msw (refer to Notes 1 and 2)
Reserve Ship's Team Diver	TBP	CABA	30 msw (refer to Notes 1 and 2)	NIL
Special Ops Swimmer, Basic	TBP	NIL	(refer to Note 4)	(refer to Note 4)
Aeromed Tech QL5A	AIQW	NIL	NIL	NIL
Aeromed Tech QL6A	ZAFV	NIL	NIL	NIL
Med Associate Officer, RCC Operator	AGEV	NIL	NIL	NIL
Med Associate Officer, RCC Supervisor	AGEW	NIL	NIL	NIL
NOTES				
<ol style="list-style-type: none"> 1. No-decompression dives only. 2. CO's authorization required for dives deeper than 15 msw. 3. For depth exceptions refer to Article 123. 4. Special Ops Swimmers commence diving training in CABA but complete their O2 Swimmer qualifications IAW Volume 4 and are not CABA qualified. 5. Will have same supervision authority as QL4 on promotion to PO2. 6. CO's authorization required for working dives deeper than 30 msw. 				

Figure 1-1 (Sheet 4 of 4) Diver Qualifications, Equipment Operating Limits and Supervisory Limits

117. RESCINDING QUALIFICATIONS

1. The CO will rescind a diver's subspecialist qualifications if the diver:
 - a. Fails to attend CAF divers re-qualification training within three years,
 - b. Fails to dive for 90 days (refer to NOTE),
 - c. Has not been medically examined IAW CFHS Order 4000-04, Shallow Water Divers Periodic Health Assessment and Medical Administration Instruction,
 - d. Fails to meet the CAF Divers' Fitness Standard, or
 - e. Refuses to dive and is not clinically unfit.

NOTE

When a diver has failed to exercise for a 90-day period, the CO must, within the next 30 days, take one of the following actions:

- a. Rescind the diver,
 - b. Obtain a waiver of rescission, or
 - c. Have the diver complete an assessment as per [paragraph 6](#) of this Article.
2. Commanding Officers have the authority to rescind a diver's qualification after appropriate investigation and documentation of grounds, such as sub-standard performance or unsuitability for employment in diving.
3. Upon rescinding a diver the Commanding Officer will:
 - a. Annotate in red ink "Rescinded Diver" on the qualification page of the personal dive log (CF 849), sign and date this annotation and repeat this annotation again immediately after the last entry in the diver's log, and
 - b. Ensure details surrounding the decision to rescind the diver are clearly documented in the member's personnel file
4. Circumstances such as injury, deployment or extended coursing may preclude the diver from maintaining the required currency as defined in [Article 116](#) or from attending the CAF Diver Re-Qualification Course IAW [paragraph 1.a.](#) of this Article. In such cases the Commanding Officer shall request a waiver of the requirement to rescind the diver's qualification from their appropriate command diving authority as follows:
 - a. CAFSME/ADC,
 - b. FDU(A)/CPO2 PID,
 - c. TRSET/CSE,
 - d. NFR, and
 - e. FDU (P)/CO.

5. All requests shall be fully substantiated and include recommendations. Waivers may be requested for any time period up to a maximum of one year from the end date of the diving qualification.
6. When a diver is no longer current, the diver must undergo a thorough in water assessment prior to resuming full diving duties.
 - a. This check-out dive may be conducted in-unit by a qualified and current Dive Supervisor or if required at a FDU. The assessment shall include as a minimum a review of [Articles 504](#) and [505](#) and a dive with an experienced diver to demonstrate emergency and mask clearing drills. Lapsed supervisors must additionally review [Articles 502](#) and [503](#).
 - b. The check-out dive must be annotated in the CF 849 on the next record of diving operations entry as follows: date, location, result of the check-out dive (including emergency procedures) and dive supervisor signature.
7. Check-out dives shall be conducted only when the specified conditions listed here have been satisfied.
 - a. When applicable, the Supervisor shall verify that the diver possesses a waiver authorized by the appropriate command diving authority at [paragraph 4](#),
 - b. The Diving Officer or senior diver shall confirm that the diver is in date for medical, dental, and physical fitness tests,
 - c. The CO shall be briefed on the plan for conducting the check-out dive,
 - d. Before the actual check-out dive, the diver shall complete all non-diving portions IAW [paragraph 6](#) (including assessment of diving supervision skills if appropriate),
 - e. The check-out dive shall be conducted under safe and controlled environmental conditions, such that both rescue and treatment (if required) can be rapidly affected. In general such dives should be conducted in a camber, a safe jetty/boat launching area, other sheltered area or a designated diving training area,
 - f. Either a qualified and current supervisor or if necessary a Clearance Diving Supervisor IAW [paragraph 6](#) shall conduct the assessment,
 - g. The diver shall be tended on a lifeline unless the dive is conducted in a swimming pool, and
 - h. The standby diver shall be at IMMEDIATE NOTICE.
8. Check-out dive shall consist of the following:
 - a. familiarisation of diving equipment;
 - b. full face mask clearing drills;
 - c. switching to redundant regulator and donning of half mask;
 - d. function reserve;
 - e. remove suit inflation whip;
 - f. buddy breathing; and
 - g. drop weights.

9. Personnel whose qualifications have been rescinded within the past twelve months may be re-qualified on successful completion of a standard re-qualification course. Personnel wishing to regain their qualification, who have been rescinded or lapsed for more than twelve months, may repeat the full course or complete the 16-day re-certification course

118. NON-DIVER ATTENDANTS

1. Under special circumstances at the supervisor's discretion, personnel not qualified in diving may be employed as attendants. Such non-diver attendants should be military personnel who possess a good sense of responsibility and the mental ability to discharge their duties efficiently and reliably. These individuals should be noted in the Unit Diving Roster (CF 850) and on the Diving Supervisor's Log Sheet.

2. They must be fully conversant with all duties of a qualified diver when acting as an attendant and be aware of the nature of the diving task in which they are involved, and having passed the diving signal exam.

3. They should be exercised with the diving team IAW the levels of proficiency stated in [Article 116](#).

119. RE-QUALIFICATION/RE-CERTIFICATION REQUIREMENTS

1. Divers attending the one-week CAF Divers' Re-Qualification Course must meet the following prerequisites (all dates are based on course start date):

- a. No more than three years have passed since initial diving training or a re-qualification course (a waiver may be granted to extend this period by one year),
- b. Be medically and dentally fit IAW CFHS Order 4000-04,
- c. Have met the CAF divers' fitness standard within the past year and
- d. Have not been rescinded for more than one year.

2. Divers attending the 16-day CAF Divers' Re-Certification Course must meet the following prerequisites (all dates are based on course start date):

- a. Be medically and dentally fit IAW CFHS Order 4000-04,
- b. Have met the CAF Fitness Standard within the past year, and
- c. Have held a CAF diving qualification at one time during their career.

NOTE

Combat divers who are employed as D Dive S 2-3 or as instructors of an authorized training establishment (ADC) will not require a re-qualification course while so employed. Re-qualification course equivalency will be granted to those members effective on their date of being posted out of the authorized dive training establishment.

SAFETY REGULATIONS

120. CABA PERSONAL REQUIRED TO CONDUCT DIVING OPERATION

1. Under optimum circumstances, diving should not take place unless six members are present. When operating from a boat, a dedicated qualified boat driver shall also be present. The diving supervisor shall not be used as an attendant except in an emergency. IAW [Article 118](#), under special circumstances and under the supervisor's discretion, a non-diver may act as a diver attendant. The responsibilities of the members of the diving team are as follows:

a. Compressed Air Breathing Apparatus (CABA)

- (1) When diving is conducted in CABA, the team shall normally comprise of the following members:
- (a) Diving Supervisor;
 - (b) Two CABA divers paired together on a buddy line and with a float line or life line secured to the lead diver;
 - (c) Diver attendant;
 - (d) Standby diver equipped with CABA;
 - (e) Standby diver attendant; and
 - (f) Boat driver (if required).

2. No more than eight divers or four pairs of divers are to be in the water at any time under the control of one Supervisor. However, when conducting training in a confined or restricted area, e.g. an FDU jackstay, the numbers may be increased to 20 divers or 10 pairs.

3. Under special/particular circumstances diving operation can be conducted with a minimum of two divers, a diving supervisor and two diver attendants. The responsibilities of the members of the minimum allowable diving team under special/particular circumstances are as follow:

- a. One diving supervisor (may also be the boat driver in smaller boats due to limited space);
- b. One diver on a lifeline attended physically or secured to a float and tended visually;
- c. One Diver attendant (refer to [Article 118](#));
- d. One standby diver; and
- e. One standby diver attendant (refer to [Article 118](#)).

4. Light-Weight Surface-Supplied Diving Equipment (LWSSDE)

- a. Under normal circumstances no less than five divers and a Diving Supervisor are required to conduct a LWSSDE dive. The responsibilities of the members of the minimum allowable diving team are as follow:
- (1) Diving Supervisor,
 - (2) Diver,
 - (3) Standby diver,
 - (4) Two diver attendants (one each for the Diver and the Standby), and
 - (5) Diving console operator/communicator.

5. Special diving procedures that deviate from these personnel limitations are laid down in [Chapters 5, 6, 7](#) and [8](#).

121. FREE-SWIMMING – GENERAL RULES

1. Free-swimming without lifelines/buddy lines shall only be carried out when the nature of the diving operation is such that the Commanding Officer considers the benefit of lifelines/buddy lines is outweighed by the risk of entanglement or other hazards. Free-swimming must be justified by the nature of the underwater task and not solely by the skill, ability and experience of the divers involved.

2. **General Conditions for Free-Swimming.** The following general conditions must be met before free-swimming can commence:

- a. A power-driven safety boat shall be manned and operated.
- b. Each diver is to carry a diver's day/night distress signal.
- c. At night each diver shall display an indicator light and a strobe light which can be activated to indicate position (refer to [Articles 148, 428](#) and [429](#)) and
- d. Two-way through-water communications and diver-carried acoustic pingers are recommended if available within the unit (also refer to [Articles 148](#), and [434](#) to [437](#) on "pingers").

3. **Free-Swimming in Pairs with Buddy Lines.** While free-swimming, divers will dive in pairs joined by a buddy line. Diving in pairs is the greatest single safety measure in CABA diving. Each diver is responsible for both the assigned task and the other's safety. No more than two pairs of divers are to be in the water at one time under the control of one Supervisor.

4. Free-Swimming in Pairs without Buddy Lines/Free-Swimming Solo

- a. There are occasions when free-swimming in pairs (without buddy lines) or free-swimming solo may take place because of the special nature of the operation. Free swimming solo is only authorized under the most urgent operational conditions and only with written authority of the CO. Training, Exercise and Work-Ups diving shall be conducted using attended divers.
- b. The minimum team to conduct a diving mission involving explosives/LMDE in a free-swimming solo mode is:
 - (1) Diving Supervisor;
 - (2) Standby diver; and
 - (3) Diver.

5. Group Navigation Control System (GNCS)

- a. GNCS is an adaptation of free-swimming in pairs that enables a group of divers to reach an objective undetected at the same time. See [Figure 7-4, Group Navigation Control System \(GNCS\)](#).
- b. Prior to commencing GNCS operations or work-up training, the procedures at [Article 526](#) shall be followed.

122. FREE-SWIMMING – CLEARANCE DIVERS

1. A team of Clearance Divers in CABA, a Clearance Diving Supervisor and a Standby Diver may conduct a dive without lifelines/buddy lines where the Supervisor considers that the benefit of lifelines/buddy lines is outweighed by the risk of entanglement or other hazards. This is an exception to [Articles 120](#) and [121](#).

2. The following conditions apply to all free-swimming by Clearance Divers:
 - a. The planned depth and bottom time are to be such that the dive does not require decompression stops.
 - b. Divers are to remain in visual contact with one another throughout the dive. If visibility is poor, a buddy line is to be worn.
 - c. The conditions of [Article 121, paragraph 2](#) are to be met. [Article 121, paragraph 3](#) is waived.
3. For underwater engineering tasks (normally under ships in harbour) where the planned depth of the dive does not exceed 30 msw, up to four Clearance Divers may free swim under the supervision of one Clearance Diving Supervisor, with one Standby Diver. A Clearance Diving Supervisor may employ qualified and experienced CAF divers as part of the four-diver team if sufficient Clearance Divers are not available.
4. For other diving tasks where the planned depth of the dive does not exceed 45 msw two Clearance Divers may free-swim under the supervision of one Clearance Diving Supervisor, with one Standby Diver, provided that the divers remain in visual contact with a descending line or shot line and with one another throughout the dive. Once on the bottom this contact may be maintained with a search line secured to the shot.

123. DEPTH LIMITATIONS

1. Maximum operational depths of Compressed Air Breathing Apparatus (CABA) and the Light-Weight Surface-Supplied Diving Equipment (LWSSDE) in current use in the CAF are:
 - a. CABA: 45 msw.
 - b. LWSSDE: 54 msw.
2. Divers' depth limits are shown in [Figure 1-1](#).
3. For no-decompression depth restrictions see [Figure 1-1](#).
4. When the planned depth of the dive exceeds:
 - a. **15 msw.** A hyperbaric chamber shall be within 4-hours travelling time.
 - b. **45 msw.** A hyperbaric chamber shall be on site.
5. **Exceptions.** The depths specified in [Figure 1-1](#) for clearance diving operations, experimental diving research or development projects and for port inspection operations may be exceeded only by the specific authority of:
 - a. National Defence Headquarters, Director Diving Safety (D DIVE S),
 - b. Commanding Officer FDU(A), FDU(P) for Diving Operations conducted by Clearance Divers to a maximum of 10 percent greater than the depths shown in [Figure 1-1](#),
 - c. The Head of EDU Grp at DRDC-Toronto for research or development projects to a maximum of 10 percent greater than the depths shown in [Figure 1-1](#), or
 - d. Operational Commander for Port Inspection Divers to a maximum of 10 percent greater than the depths shown in [Figure 1-1](#).

124. LIFELINES, FLOAT DIVING, MARKED SWIMMING AND MARKING OF LINES

NOTE

[Chapter 1, Annex B1](#), *Definitions Applicable to CAF Diving*, should be read in conjunction with this Article.

1. Lifelines shall be, IAW [Figure 1-2](#), 7 mm minimum diameter, 60-metres maximum continuous length line with a minimum breaking strength of 340 kg and shall not be lengthened or joined to additional lengths. The standby diver's lifeline must be 15 metres longer than the longest diver's lifeline.
2. A diver shall normally be securely attached to a lifeline and shall be tended by an attendant. The lifeline shall be secured to the diver using either a bowline and two half hitches or a splice to a locking carabineer (minimum rating 20 kN or 2040 kg, [Figure 1-2](#)) connected to the diver's harness, or using a bowline and two half-hitches to secure a bight of lifeline around the diver's waist. If using a three-stranded line, the carabineer splice shall have a minimum of five tucks. Lifelines shall be secured in such a manner that the diver's weights and breathing apparatus can be ditched without being fouled by the line and without the line becoming detached from the diver. The diver's attendant is responsible for ensuring that the diver is so secured and that the inboard line end is firmly secured at the surface.
3. The Diving Supervisor may authorize float diving in pairs where the lifeline (no longer than the planned depth of the dive) is securely fastened to a float of sufficient buoyancy to support the divers in their heaviest condition. There are occasions when float diving solo in CABA may take place because of the special nature of the task/operation. If extra line is provided to give greater freedom to the diver at depth, it shall be included in the total depth of the dive for planning purposes.
4. When float diving/marked swimming in pairs, the diver wearing the float/marker will be the first to enter the water and the last to exit.
5. If the task requires, the Diving Supervisor may authorize marked swimming or marked swimming in pairs. A light line of sufficient length to reach the maximum depth of water is secured to a diver and to a small marker (i.e. a small block of wood or Styrofoam). This is used merely to indicate the diver's position and should not be confused with float diving nor substituted for it without a good reason. Marked swimming is prohibited if the depth of water exceeds the diver's depth qualifications (see [Figure 1-1](#)).
6. All lines used for controlling the depth of the diver are to be marked as outlined below. See [Figure 1-3](#), Marking of Lines.
 - a. Starting from the diver's end, lines are to be marked every 15 metres by one wide band of a contrasting colour for every multiple of 15 metres. For example, three wide bands would be used to indicate the 45-metre. In addition, every 15-metre length is to be marked at each 3-metre interval by a narrow band of another contrasting colour for each multiple of 3 metres. For example, four narrow bands would be used to mark the 12-metre mark and the 36-metre mark would have two wide and two narrow bands. The widths of the narrow bands are 1 cm and as a general rule, the wide 15-metre bands should be twice as wide as the narrow 3-metre bands and of a different colour. All whippings should have 1 cm spacing between markings.
 - b. Synthetic whipping should be used for marking lifelines and umbilicals. Using turns of contrasting coloured whipping 1 cm apart, mark the line by weaving the whipping material through the strands before completing the length of marking. The whipping is to be applied so that the lower whipping or the first whipping of the group to enter the water is at the depth to which the combination refers.
 - c. Coloured tape may also be used to mark the depth. It should be weaved through the stands then completed by taking two complete turns.

Rope	Description and min. Dimensions	Recommended Materials	Rope colour	Colour of THIN whippings	Colour of THICK whippings	Colour of Storage Bag
CABA Diver Life line NSN 4020-20-006-1958	7 mm (min) X 60M BS* 340 kg	Olefin/Nylon, Braided	White	Yellow	Black	White BCM3 NSN 4220-20-008-1894
CABA Standby Diver Life Line NSN 4020-02-006-1960	7 mm (min) X 75M BS* 340 kg	Olefin/Nylon, Braided	Red or Orange	Yellow	Black	Red BCM3 NSN 4220-20-008-1890
Shot line NSN 4020-20-006-1961	18 mm X 60 m BS* 900 kg	Nylon, Braided	Green	Yellow	Black	Green BCM3 NSN 4220-20-008-1895
Lazy Shot NSN 4020-20-006-1962	7 mm (min) X 42M BS* 750 kg	Nylon, Braided	Light Green	Yellow	Black	Light Green BCM3 NSN 4220-20-008-1892
LINES REQUIRED FOR ICE DIVING						
Ice diving Lifelines NSN 4020-20-006-1963	7 mm (min) X 45 m BS* 340 kg	Polypropylene 3 ply	(1) Yellow (1) Orange	White	Black	NSN 4220-01-601-3671
Ice Diving Standby Lifeline NSN 4020-20-006-1964	7 mm (min) X 60 M BS* 340 kg	Polypropylene 3 ply	Light Blue	White	Black	NSN 8465-01-599-9798
Ice diving Diver's Buddy line NSN 4020-20-006-1965	7 mm (min) X 4 m BS* 340 kg	Polypropylene 3 ply	Orange	Black		Pouch on side of ice dive storage bag
Distance Line						
GNCS Line	As required
NOTES						
* = Minimum Breaking Strength						
1. Lifeline Marking. All lines are to be marked IAW Article 124 . See also Figure 1-3 .						
2. Line Construction. All line diameters are the minimum permissible. Larger diameter lifelines may be used for ease of handling.						
3. Standby diver lifeline must be 15 m longer than the longest diver lifeline and red or orange in colour.						

Figure 1-2 Diving Lines and Shots

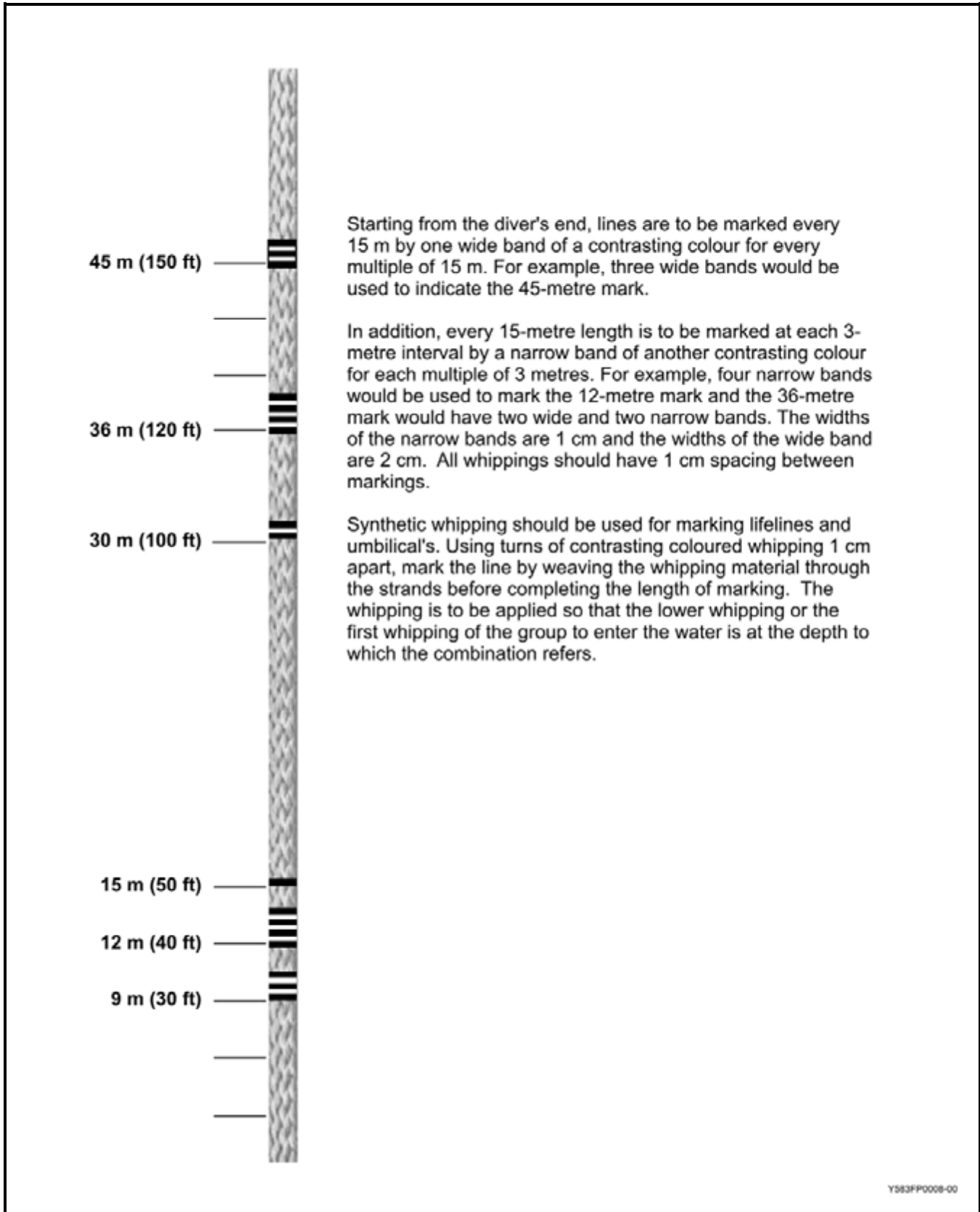

Figure 1-3 Marking of Lines

125. BUDDY LINES

1. The buddy line (Buddy Line Attachment Assembly) is made up as follows:
 - a. **Diver Attachment.** 127 mm inside diameter loop with a 178 mm tail of 38 mm (width) tubular nylon webbing, total 300 mm, with a female 38 mm (1.5 in.) FASTEX© buckle sewn into the loop.
 - b. **Line Attachment**
 - (1) 76 mm inside diameter loop of 38 mm tubular nylon webbing, with a male 38 mm FASTEX© buckle sewn into the loop.
 - (2) The connecting line will be no less than 4 mm high-quality synthetic line 2 to 4 metres in length attached to the loop by a bowline knot.
2. Divers should use a bowline knot and two half-hitches to tie each end of the Buddy line to the line attachment point.
3. The diver attachment loop shall be choked on itself after passing around and through one of the following:
 - a. Buoyancy compensator “D”-rings; or
 - b. Diver’s lifeline harness webbing.
4. Buddy lines shall not be attached to a diver when jumping into the water from an elevated position such as the quarterdeck of a ship, a jetty or a helicopter.
5. Prior to jumping into the water from an elevated platform, the diver shall be checked for any possible snagged equipment or lines and shall be given a verbal clearance that it is safe to proceed.
6. The Buddy line shall be attached between the lead diver and the buddy diver as described in [Article 504, paragraph 2.](#)

126. SAFETY BOATS

1. A power-driven safety boat displaying the appropriate warning signals as described in [Article 147](#) shall be underway in the vicinity of diving operations unless divers are carrying out attended diving on lifelines from a ship or jetty.
2. The equipment required in the boat is listed at [Figure 5-9, CAF Diving Safety Equipment Requirements.](#)

127. DIVERS IN BOATS UNDERWAY

1. Those in charge of boats carrying divers must always keep in mind the safety of the diver. If a diver is wearing a incompressible dry suit, it shall be completely zipped up and the weights removed.

128. FIRST-AID EQUIPMENT

1. The standardized CAF Dive Team Medical Kit (CAFDTMK) and an oxygen resuscitator are essential items that are to be kept at every dive site.
2. All items as listed in [Figure 1-4](#) are mandatory to have on the dive site/in the safety boat. The C-Spine Immobilization portion of the CAFDTMK may be too large to be taken on small safety boats, and may remain on shore in the dive support vehicles. If room permits in the boat/vessel supporting dive ops, the complete kit should be taken.

NSN	Item Name	Description	UI	Qty
6510-21-116-0154	Bandage Elastic Adhesive Back 7.5 cm x 4.6 m Rolled	Bandage Elastic Adhesive Back 7.5 cm x 4.6 m Rolled, Skin Colour, One Side Coated With Adhesive Backing	EA	1
6510-01-586-4314	Bandage Trauma 20 in. x 20 in.	Bandage, Pad, Non-adherent, 20 in. x 20 in., with Attached Elastic Strap for Traumatic Amputations, Burns and Large Pattern Wounds	EA	1
6510-21-849-8650	Bandage, Adhesive	4 ply Absorbent Gauze Pad; Sterilized; Elastic Cloth Backing; 3.8 cm Wide; 7.5 cm Long; Box of 100; Brand: Covoplast Knuckle Dressings	BX	0.25
6510-cf-002-0901	Bandage, Adhesive, Blister Prevention And Treatment, Latex-free, Sterile, Small	Bandage, Adhesive, Blister Prevention and Treatment, Latex-free, Sterile, Translucent, 1.5 in. x 2.4 in. Oval	EA	2
6510-21-851-4200	Bandage, Compress, Sterile, 10 cm x 10 cm (4 in. x4 in.) pg(10)	10.1 x 213.3 cm, Compressed, with 10.1 x 10.1 cm Compress, Individually Wrapped in Envelope	EA	3
6510-01-558-3342	Dressing Modular 4 in.	Dressing, Modular, 4 in., w/ Pressure Gauge, Latex-free	EA	3
6510-CF-001-7793	Dressing Strip 4 cm x 5 m	Bandage AHD (4-p) Gauze Pad 4.0 cm x 5.0 m Strip Form of Elastic Adhesive Plaster Faced With Plastic Flesh Color	RO	1
6510-01-621-1129	Dressing, Chest Seal Wound, Non-valved	Dressing, Chest Seal Wound, Non-valved	EA	2
6510-01-606-7097	Dressing, Chest Seal Wound, Valved	Dressing, Chest Seal Wound, Valved	EA	2
6510-21-899-4382	Dressing, Transparent Gel Kit	Nonsterile; 96% Water and 4% Polyethylene Oxide; 7.5 cm x 16.25 cm; Package of 2 Moist Pads; Spenco Medical Corp #47-209	PG	1
6510-CF-001-9836	Pad, Chlorhexidine .5%/Alcohol 70%	Pad Impregnated with Isopropyl Alcohol 70% and Chlorhexidine 0.5% Individually Sealed 200 ea/bx	EA	0.5
6510-21-116-0202	Pad, Nonadherent	7.5 cm W x 10.1 cm Lg, Telfa; Strip Form; Perforated Plastic Film with Absorbent Cotton Backing; White Color; Individually Sealed in Envelope	EA	10
6510-21-860-8464	Skin Closure, Adhesive, Surgical	6.3 mm W x 7.6 cm Lg; Strip of Adhesive Plaster with Fiber Backing, Sterile Packaged in Envelope, Three Strips per Envelope; Box of 50 Envelopes	BX	1

Figure 1-4 (Sheet 1 of 4) CAFDTMK Contents

NSN	Item Name	Description	UI	Qty
6515-21-878-1120	Airway, Pharyngeal	Guedel Design, Transparent Resilient Polyvinyl. Child Size 2, 68 mm	EA	1
6515-21-878-1122	Airway, Pharyngeal	Guedel Design, Transparent Resilient Polyvinyl. Adult Size 4, 90 mm	EA	1
6515-21-884-3180	Airway, Pharyngeal	Guedel Design, Transparent Resilient Polyvinyl. Child Size 3, 80 mm	EA	1
6515-21-884-3181	Airway, Pharyngeal	Guedel Design, Transparent Resilient Polyvinyl. Infant Size 1, 60 mm	EA	1
6515-21-884-3182	Airway, Pharyngeal	Guedel Design, Transparent Resilient Polyvinyl. Adult, Size 5, 100 mm	EA	1
6515-CF-002-7569	Cannula Nasal 7 ft O2	Cannula, Nasal, Flare Tip, 7 ft Crush Resistant Oxygen Tubing, Adult Size, with Angulated Flexible Lip Plate	EA	1
6515-01-452-5833	Connector, Ventilator	Plastic; Large Tubing; Standard 22 mm O.D Connection; Disposable	EA	1
6515-00-337-2400	Forceps, Splinter	Corrosion Resistant Steel, Straight, Fine Serrated Pointed Tips, 8.5 cm to 10.1 cm Lg	EA	1
6515-cf-002-7589	Glove Ex Nit LF PF NS Lg	Glove, Exam, Nitrile, Latex-Free, Powder-Free, Non-Sterile, Extended Cuff, Stretchy Material, Large	BX	0.4
6515-CF-002-8539	Kit, Temperature Monitoring, Continuous	Kit, Temperature Monitoring, Continuous, Audible and Visual Alarms with Case	EA	1
6515-CF-002-1607	Mask Oxygen (Adult)	Mask, Oxygen, Non-Rebreather, Adult, Vinyl, w/Safety Vent, w/ 7ft Tubing.	EA	1
6515-21-904-7049	Mask, Mouth, Resuscitator	Mask, Mouth Resuscitator "Prosafe"™ to Fit Adult and Child, Reusable, Comes with Strap and One-way Disposable Valve (O2) Assembly	EA	1
6515-CF-002-8619	Pads, Heat, Oxygen Activated, Set of 4 Used with Blanket 6532-01-524-6932	Pads, Heat, Oxygen Activated, Set of 4 Used with Blanket 6532-01-524-6932	SE	1
6515-CF-002-6004	Pouch Empty Nylon Window	Pouch, Empty, Black Nylon, Clear Plastic Window, 7 in. x 9 in. x 3 in., YKK Nylon Zipper (5 cm Wide), Black Nylon Webbing (1 in. and 2 in. Wide)	EA	1
6515-CF-002-7984	Pulse Oximeter Wireless	Pulse Oximeter, Wireless, Finger Tip, Colour Display, Displays SpO2 and Heart Rate, Comes with Carrying Case, Lanyard and Batteries	EA	1

Figure 1-4 (Sheet 2 of 4) CAFDTMK Contents

NSN	Item Name	Description	UI	Qty
6515-CF-001-9074	Resuscitator Disposable Adult	AMBU Medibag Adult. MDI Single Patient Use Resuscitator with Oxygen Tubing, Reservoir Bag and MediPort with Medium Adult Mask. SM Part No. 450611000 - 107.94/CA of 6	EA	1
6515-CF-002-8555	Scalpel Disp 11 Safety Shield	Scalpel, Bard-Parker Design, Size 11, Stainless Steel, Disposable with Locking Retractable Safety Shield and No Slip Grip	EA	2
6515-21-878-1957	Scissors, Universal	Almedic Design; Stainless Steel, Acid Proof, Blunt Ends, Serrated Edges, with Plastic Covered Finger Rings, Accessories: Holster (6515-21-878-1958)	EA	2
6515-21-903-0672	Splint, Universal	"Quick Splint" Malleable; Light Weight Aluminum; Coated with Foam; 900 mm Lg x 110 mm W x 5 mm Thk Overall; Radioluscent; Can Be Cut with Scissors	EA	2
6515-CF-002-7539	Suction DVC Tact Airway	Suction Device, Tactical, Airway, 1000 ml Bag, 100 mm Hg Vacuum Force Double Valved, Contoured Suction Top	EA	2
6515-21-877-1517	Tubing Assembly, Plastic, Oxygen Inhalation	2.10 m Lg Overall; Used with: Cannula (6515-21-894-0036)	EA	1
6515-CF-001-6515	Valve One-Way	Valve One-way Replacement Mask U/W (6515-21-904-7049) Mouth Resuscitator	EA	1
6532-01-524-6932	Blanket Casualty Hypothermia w/ 4 Heat Pads	Blanket, Casualty, Hypothermia Prevention & Management with 4 Oxygen Activated Heat Pads, Vacuum Sealed, 3 in. x 9 in. x 12 in.	EA	1
6545-CF-002-0271	Kit, Oropharyngeal Airways (OPA's) 8 Airways Sizes: 40 mm to 110 mm	Kit, Oropharyngeal Airways (OPA's) 8 Airways Sizes: 40 mm to 110 mm, in Plastic Orange Case, Colour Coded	EA	1
6545-20-A0M-1004	Kit, TMT, C.A.F. Dive Team C-Spine Immobilization	Kit, TMT, C.A.F. Dive Team C-Spine Immobilization	KT	1
6760-01-491-2710	Case, Pelican 1550, Orange with Foam	Case, Pelican 1550, Orange with Foam, Lockable, 18.4 in. x 14 in. x 7.6 in.	EA	1
6515-CF-002-8619	Pads, Heat, Oxygen Activated, Set of 4 Used with Blanket 6532-01-524-6932	Pads, Heat, Oxygen Activated, Set of 4 Used with Blanket 6532-01-524-6932	SE	1
6515-21-903-0672	Splint, Universal	"Quick Splint" Malleable; Light Weight Aluminum; Coated with Foam; 900 mm Lg x 110 mm W x 5 mm Thk Overall; Radioluscent; Can Be Cut with Scissors	EA	2

Figure 1-4 (Sheet 3 of 4) CAFDTMK Contents

NSN	Item Name	Description	UI	Qty
6515-01-452-4435	Support, Cervical	Extrication Collar; Adjustable to Four Sizes - Tall, Regular, Short, and No-neck; Brand - Laerdal Stifneck Select; One Size Fits All	EA	2
6530-CF-001-7724	Board Spinal "Baxstrap"	Board Spinal Fracture "Baxstrap"™ Plastic 2, 500 lbs Distributed Weight. Laerdal # 98-25-00	EA	1
6530-CF-001-7725	Restraint Fast Patient	Restraint Harness, Fast Application Version, with 10 Color Coded Restraint Points, for Patient Immobilization	EA	1
6530-01-450-7213	Restraint, Head	Universal Head Immobilizer; Ferno Model 445; 2 Side Support Blocks; Complete with 1 ea Head/Chin Strap; 1 ea Assembly Base	EA	1
6532-01-524-6932	Blanket Casualty Hypothermia w/ 4 Heat Pads	Blanket, Casualty, Hypothermia Prevention and Management with 4 Oxygen Activated Heat Pads, Vacuum Sealed, 3 in. x 9 in. x 12 in.	EA	1
9930-01-331-6244	Pouch, Human Remains	CFSS Item; Current Use, Cotton Duck, 6 oz per sq yd, 3 Webbing Loops Either Side, Full Length Slide Fastener, Vinyl Coated, 94 in. Lg x 30 in. W.	EA	1

Figure 1-4 (Sheet 4 of 4) CAFDTMK Contents

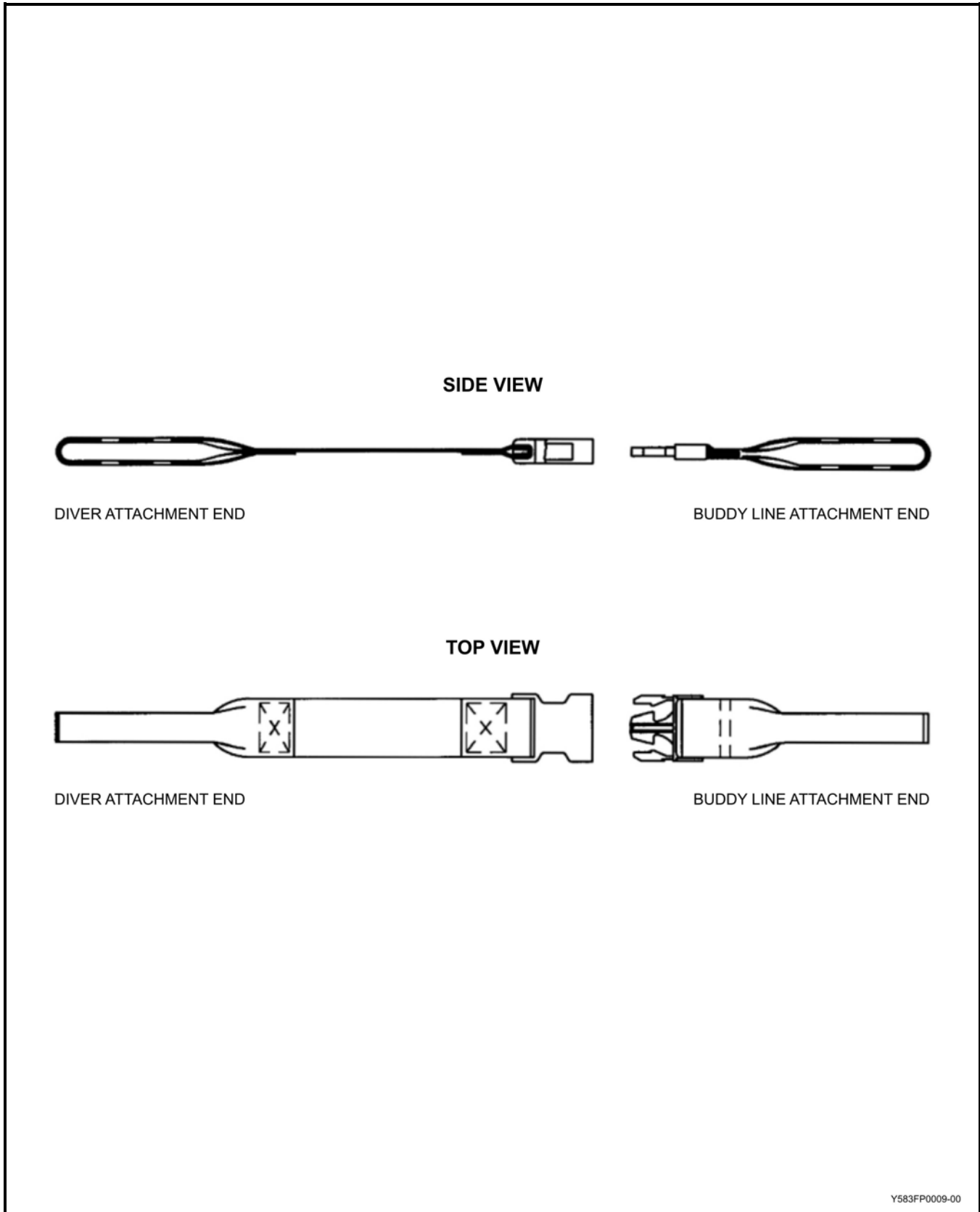

Figure 1-5 Buddy Line

129. WEARING OF KNIVES

1. All divers are to carry knives when underwater and when acting as supervisor, standby divers or attendants.
2. A second knife, known as a safety knife, is required for all diving operations. This knife shall be worn in the safety triangle between the diver's waist and neck within easy reach with either hand. This does not mandate the sole use of the cummerbund for securing the knife sheath to the BDCMV BC.
 - a. The knife may be worn on either shoulder provided that the sheath is secured to the BDCMV by at least two physical securing methods (e.g. tie strap, strobe holders), and that the diver's partner and standby diver are aware of the location. (e.g. [Figure 1-6](#)).



Figure 1-6 Knife Mounting Locations

130. MEALS AND ALCOHOL

1. Diving is not to take place within:
 - a. Six (6) hours of consumption of alcohol; and
 - b. Two (2) hours of consumption of a heavy meal. However, diving should not take place on an empty stomach. The diver should take a light snack before diving.
2. Before diving is carried out, the Diving Supervisor must ensure that the efficiency of a diver has not been impaired by the consumption of alcohol or medication (refer to [Article 136](#)).

131. DENTURES AND PIERCINGS

1. Dentures and all non-permanent fixtures (e.g. piercings) must always be removed before diving. They could be dislodged during the dive and obstruct the air passage, with potentially fatal results should the diver lose consciousness.

132. CONTACT LENS

1. Hard-style, unvented contact lenses are not to be worn while diving. Gas may be trapped under the lens resulting in injury to the eyes.

2. Soft-style contact lenses and vented hard-style lens may be worn.

133. MEDICATIONS AND DIVING

1. Prior to diving, the diver shall report to the Supervisor all drugs, medications or supplements, whether prescribed or over-the-counter, that a medical officer or physician has authorized them to take while diving.

2. Divers must also inform the Supervisor of any medication taken without such authorization. If there is any doubt as to the safety of the diver, the diver shall not be permitted to dive. If necessary, written authorization of a medical officer or physician may be provided to the Supervisor.

3. Drug reactions such as sleepiness, nausea, dizziness, weakness, skin rash, etc. shall be reported immediately by the diver to the Supervisor who will refer the diver to a medical officer or physician for a decision concerning temporary restriction from diving duties. Also refer to [Article 130](#).

4. When required, medical officers and physicians may seek advice on the effects of a diver's medication from the Consultant in Diving and Hyperbaric Medicine at DRDC – Toronto. Refer to [page i/ii, Diving Emergency Assistance/Medical Consultation](#).

134. FEMALE DIVERS

1. Current knowledge indicates female divers are at no greater risk of developing decompression sickness than males. However, FEMALES WHILE PREGNANT SHALL NOT DIVE UNDER ANY CIRCUMSTANCES.

2. A female diver who suspects she is pregnant shall not dive and is to report to a medical officer immediately for confirmation. If pregnancy is confirmed she shall be declared "UNFIT FOR DIVING" and her CAF 849 annotated accordingly. Prior to resuming diving duties the diver must be cleared by a Diving Medical Officer and her CAF 849 annotated as "FIT TO DIVE".

135. USE OF CAF DIVING EQUIPMENT

1. Only current and qualified CAF divers are authorized to use CAF diving equipment (the only exception is [Article 112](#), Allied divers).

2. All dives using Service equipment will be defined as either operational, training or proficiency dives and will comply with rules and regulations contained in the CAF Diving Manual.

136. USE OF NON-CAF DIVING EQUIPMENT

1. Use of non-CAF personal diving equipment for CAF diving operations is at the discretion of the Diving Supervisor.

2. However, the following essential diving support equipment must not be substituted:

- a. CABA cylinders;
- b. CABA regulators with integrated mask;

- c. Buoyancy compensators;
- d. Weights; and
- e. Approved diving suit.

3. Deployed dive team Commanding Officers may authorize the use of non-service CABA cylinders if they determine that the logistic and cost benefit of utilizing non-service CABA cylinders is greater than using in-service CABA cylinders and that the following requirements are met:

- a. The dive team officer/supervisor must ensure the intended equipment provider is certified by a known and credible civilian/military dive organization and the maintenance/testing of their CABA cylinders meets the CAF standards of (1) hydrostatic testing completed every 5 years/(60 months) by an authorized technical facility and (2) an annual visual inspection is completed by a qualified technician. Supporting maintenance documentation must also be provided to the dive officer/supervisor by the equipment provider prior to deployment.
- b. Once on site the dive supervisors must physically check the CABA cylinders to ensure (1) the hydro stamp and annual visual inspection stickers are in date along with (2) a check of the CABA cylinder valve for serviceability.
- c. If CABA cylinders are not marked by a visual maintenance sticker supporting documentation confirming the visual maintenance was carried out must be provided prior to use.
- d. Air sample requirements from non CAF sources remain the same IAW [Article 144](#).

137. BUOYANCY COMPENSATOR (BC)

1. The Buoyancy Compensator (BC) is a primary piece of life support equipment for the diver and shall be worn by all CAF divers dressed in CABA equipment.
2. Buoyancy compensators shall NOT be used by the diver to assist in carrying heavy items underwater. The excess positive buoyancy that this would require could cause an uncontrolled ascent if the object being carried were dropped. A separate lifting bag or working line should be used.

138. HP AIR/GAS CYLINDER TESTS

1. All HP air and gas diving cylinders used in conjunction with diving operations shall be hydrostatically tested IAW CFTOs (refer to Chapter 1, [Annex C1](#), *Orders and Reference Publications Pertaining to CABA Diving*) at intervals of five years (60-monthly) by the appropriate dockyard.
2. Diving cylinders that have exceeded five years (60 months) since their last stamped or documented hydrostatic test are not to be used until retested.
3. CABA cylinders must also have an annual internal visual inspection by an authorized Clearance Diver.

139. DIVING EQUIPMENT MAINTENANCE

1. Service diving equipment and diving support equipment shall be tested, repaired and maintained by qualified personnel IAW appropriate CFTOs. Refer also to the Diving DAODs for amplification of policy on diving equipment.
2. Should no relevant CFTO be in existence, operators and maintainers shall comply with the manufacturer's recommendations for maintenance, in consultation with NDHQ (DNPS). These directives will normally be found in the appropriate repair manuals for the equipment concerned.

3. Diving equipment is life support equipment. A high level of quality control is necessary in carrying out repairs to these equipments. Maintenance personnel are to be aware of the hazards in handling high-pressure gases, toxic and contaminating vapours and the explosive hazard resulting from mixing oxygen and hydrocarbons.

4. If the proper operation of any piece of diving life support equipment is suspect, it shall be quarantined and appropriately tagged or labeled. The originating unit shall consult with the LCMM and D DIVE S, after which it may be shipped to the nearest FDU for examination. To ensure effective tracking, the originating unit is to advise the receiving FDU (info the LCMM and D DIVE S) by message of the circumstances of the investigation, expected delivery date and method of shipping. A copy of Diving Incident/Accident Form No. 3 and the Diving Life Support Equipment Failure Investigation Report (Form 0) shall accompany the equipment. The receiving FDU shall acknowledge receipt of the equipment and prepare Form No. 4 for D DIVE S and the originating unit. This procedure is to be utilized even when it has been determined that a full set of Accident/Incident Forms is not required.

5. Refer to [Chapter 4](#) for direction specifically applicable to CABA maintenance.

140. PURITY OF COMPRESSED BREATHING AIR AND GASES FOR DIVERS

1. Although it is possible to breathe small concentrations of various toxic gases on the surface with no observable effect on the body, at depth the partial pressure of these gases will be greater and their effect can be magnified considerably. Great care must therefore be taken to ensure that breathing gases are pure.

2. The standards required by the CAF for the purity of compressed air and gases supplied from pressurised containers or from air compressors (refer to [Article 438](#), Air Compressors), intended for human respiration underwater or in hyperbaric chambers are detailed in D-87-003-000/SG-001, Purity of Compressed Breathing Air and Gases for Divers. All compressed air or gases intended for diving purposes shall meet these standards.

3. Samples of breathing air are to be forwarded to a laboratory for analysis IAW C-87-020-001/NG-001, Special Test Instructions: Divers' Breathing Air Analysis, at intervals not exceeding six months so that purity may be confirmed.

NOTE

There is no requirement for an air sample after the Securus filter has been changed as a result of a flashing yellow light.

4. Urgent sampling may be necessitated by operational requirements, unscheduled maintenance or suspected contamination. Instructions for rush air sampling are promulgated in C-87-020-001/NG-001.

141. UTILIZING DIVING AIR FROM NON-CAF SOURCES

1. Planning for diving operations, exercises and training must take into account the replenishment of diving air. Except as outlined here, teams are to utilize CAF compressors.

2. When a CAF compressor for a deployed team cannot be arranged, the Diving Officer must justify and obtain written authority through the chain of command to proceed, utilizing a non-CAF air source. The command authority granting approval shall determine whether a CAF air source is available, feasible and practical, and detail in writing the course of action to be taken by the diving team. Since the standing CAF air quality program is established and funded to support CAF assets only, all costs associated with non-CAF air source testing must be borne by the requesting unit or command.

3. It is essential for safety that the quality of non-CAF air be confirmed with in CAF breathing air standards in advance of any diving. To address this requirement, the following procedure is authorized:
 - a. If sample is not within CAF standards, CoC(s) may initiate a waiver request through SADMASP and D Dive S and carry out the test procedures outline in [paragraphs 3.b.](#) to [3.g.](#)
 - b. The diving team OPI is to send a sample cylinder, plus the directions contained in C-87-020-001/NG-001, to the facility that will be supplying the air.
 - c. The operator of the facility is to be requested to provide an air sample as directed in C-87-020-001/NG-001 and return the sample cylinder to the diving team OPI.
 - d. The team OPI is to ensure all documentation is correct and forward the sample cylinder and its paperwork IAW current CAF procedures.
 - e. DNPS will ensure the report on the sample results follows normal distribution.
 - f. If the sample meets or exceeds CAF purity standards in D-87-003-000/SG-001, the specific source tested is acceptable for CAF use for a period of six months from the test date, and the command authority at [paragraph 2](#) may authorize its use. If required, technical and scientific assistance in interpreting the results is available from DRDC – Toronto HHG.
 - g. A copy of the air sample results and the command authority to use non-CAF air is to be available at the dive site and kept with the diving team’s records.
4. On receipt of the completed waiver request, authority and responsibility to dive rest with the unit operational Chain of Command, based on recommendations detailed in the waiver.
5. Completed non-CAF air source waivers to be forwarded to D Dive S for historical and record keeping purposes.

142. HOT/WARM WEATHER DIVING CONDITIONS

1. In hot weather, particular attention must be given to maintaining work/rest schedules and essential water consumption to prevent heatstroke and hyperthermia. Even in warm weather, a fully dressed diver will undergo considerable heat stress, as sweating will produce no cooling effect. It is very important to understand that severe heat stress can escalate rapidly to unconsciousness and death in extreme circumstances. It may not be possible to reverse the symptoms after a certain point, when the body’s metabolic control system begins to break down. It is not comparable to recovery from hypothermia (abnormally low body temperature) as addressed in [Chapter 2](#).
2. The work/rest schedules and levels of water consumption provided in [Figure 1-7](#) are intended for maintaining long-term operations. These were developed based on non-diving individuals who were acclimatized to heat stress, thus they should be fully implemented in order to protect dressed divers. Improved guidance will be promulgated when available.
3. As a method of improving performance and preventing hyperthermia divers should be acclimated to heat as part of a deployment. For most individuals this will occur within one week of arrival in the hot region.
4. Hydration rates are **mandatory**. The work/rest schedules should be adhered to at all times.
5. The Standby Diver, if fully dressed in diving equipment, is treated at the Moderate Work Rate.
6. Extreme conditions beyond the upper scales of the table require extra vigilance on the condition of the divers and should be avoided when possible. Additional protective measures should be taken such as providing shade, wearing cooling jackets if available, and dousing with water.

Maximum Expected Air Temperature at Dive Site

Diver Work Rate ↓	1		2		3		4		5	
	26°C (78°F)		28°C (82°F)		29°C (85°F)		31°C (88°F)		32°C (90°F)	
	Rest (min/hr)	Water	Rest (min/hr)	Water	Rest (min/hr)	Water	Rest (min/hr)	Water	Rest (min/hr)	Water
LIGHT	0	☉	0	☉	0	☉	0	☉	10	●
MODERATE	0	☉	10	☉	20	☉	30	☉	40	●
HEAVY	20	☉	30	●	30	●	40	●	50	●

☉	☉	●
0.5	0.75	1.0
litres/hour	litres/hour	litres/hour

DIVER WORK RATE EXAMPLES

LIGHTSlow walking on hard bottom / swimming: 0.5 knot

MODERATESlow walking on mud bottom / swimming: 0.85 knot

HEAVYMax speed walking on mud bottom / swimming: 1+ knot

This Table has been adapted from the original non-diving version, with acknowledgements to:

SJ Montain, WA Latzka and MN Sawka (1999). *Fluid replacement recommendations for training in hot weather. Mil. Med. 164: 502-508.*

MA Kolka, WA Latzka, SJ Montain, WP Corr, K O'Brien and MN Sawka (2003). *Effectiveness of revised fluid replacement guidelines for military training in hot weather. Aviat. Space Environ. Med. 74: 242-246.*

During, JVGA and R Passmore (1967). *Energy, Work and Leisure. London Heinemann Educational Books Ltd., p. 84.*

Y583FP0011-00

Figure 1-7 Thermal Hydration Table

143. COLD WEATHER DIVING CONDITIONS

1. Diving under cold weather conditions exposes the diver and surface personnel to a variety of hazards including air supply freeze-up, frostbite and hypothermia.
2. Special considerations must be taken into account by the Diving Supervisor when surface conditions fall beyond ZONE A in [Figure 1-9](#), Wind Chill Index Chart. (CD-ROM: see also Environment Canada/Environment Canada ChillDex/FroiDex chart.)
3. Before diving commences the Diving Supervisor must consider:
 - a. The warmth and comfort of divers and surface personnel,
 - b. The availability of shelter and extra insulating garments, and
 - c. Whether to limit the duration of the dive(s).
4. [Article 215](#), *Hypothermia* and Chapter 5, [Annex B5](#), *Ice Diving Standard Operating Procedures – CABA/LWSSDE*, give specific procedures and information on cold weather diving and required precautions.

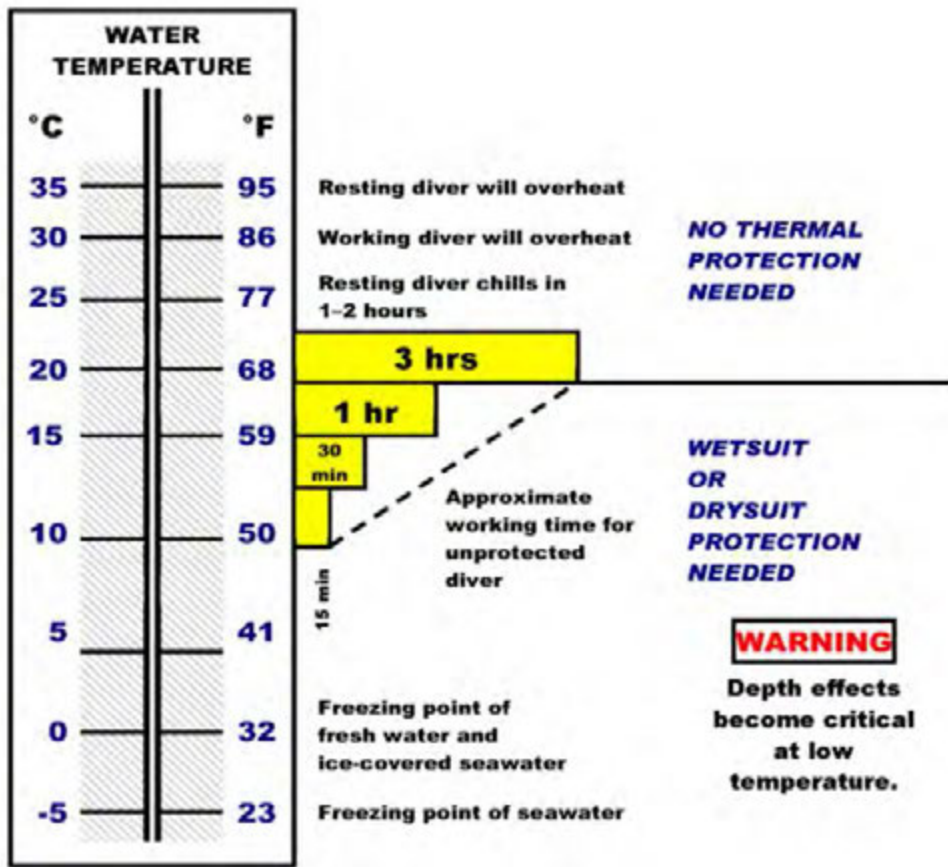

Y583FP0012-00

Figure 1-8 Thermal Factors Affecting Divers

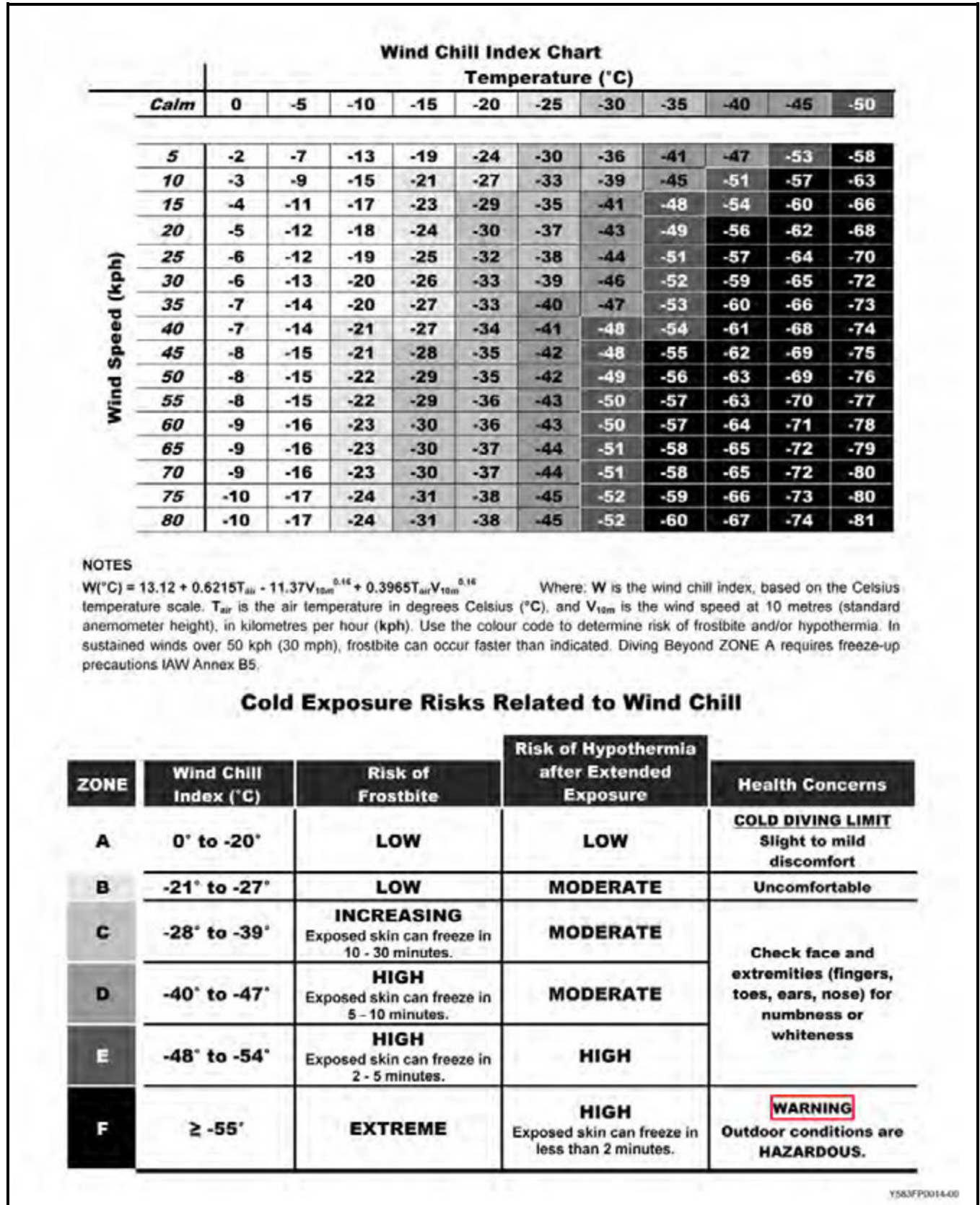

Figure 1-9 Wind Chill Index Chart

144. CONTAMINATED WATER DIVING

1. Diving can be conducted in moderately contaminated waters, provided that the appropriate CAF diving personal protective equipment is worn
2. Determining the level of water contamination is difficult and the tools or resources are limited to measure contamination levels. If the level of contamination is suspected to be higher than the capabilities of CAF dive equipment, PMED, Environment Canada, FDU's, and other outside agencies should be consulted prior to conducting dive operations. Refer to [Articles 532](#) to [538](#) for procedures and precautions.

145. REDUCED UNDERWATER VISIBILITY

1. When underwater visibility is poor or nil, certain additional procedures, precautions and restrictions are required.
2. Free-swimming is further restricted as described in [Articles 121](#) and [122](#) and an underwater pingers may be required IAW [Article 436](#).
3. Underwater signals IAW [Article 148](#) and [Figure 1-12](#) may need to be passed by arm-squeezes and if necessary for the task, additional signals provided during the pre-dive brief.
4. If decompression is planned and it is likely the diver may lose contact with the shot line, a means must be provided for the diver to regain the shot line or to safely ascend to the stop depth.

146. POOL DIVING

1. Conducting dives in swimming pools provides an alternative means of maintaining a diver's currency. Pool diving is also used to conduct initial diver selection and training. It should however be noted that pool diving is neither equivalent to nor a substitute for the conduct of realistic training at open-water sites.
2. As the diving hazards associated with pool diving are less than those of open waters, certain rules and regulations may be relaxed. The Notes in [Figure 5-3, Diving Supervisor's Checklist \(CABA/LWSSDE\)](#), and [Figure 5-9, CAF Diving Safety Equipment Requirements](#), indicate the permitted relaxations during pool diving.
3. The risk of embolism remains significant and all divers are to be reminded that typical swimming pool depths may easily result in embolism if the diver fails to breathe normally or to continuously exhale upon ascent.
4. Unqualified divers (e.g. diving course candidates) shall not use breathing apparatus unless under the auspices of a CAF diving training establishment.
5. It is essential that the dive is supervised and conducted as a CAF dive and not as a swimming evolution. A qualified standby diver must be on site. A lifeguard is not required in this situation.

DIVING SIGNALS

147. WARNING SIGNALS

1. When diving operations are in progress, the Diving Supervisor is responsible for ensuring that appropriate signals are displayed as follows:
 - a. **By Day**
 - (1) Code Alpha (and in small craft a rigid replica of Code Alpha) visible all around the horizon and not less than 1 metre above the water line.
 - (2) In waters where merchant traffic may be encountered, three shapes in a vertical line where they can best be seen. The highest and lowest of these shapes shall be balls and the middle one a diamond. This is in addition to [paragraph 1.a.\(1\)](#) Small craft need only display a rigid replica of Code Alpha.

- (3) In areas where pleasure craft are operating it is recommended that the civilian SCUBA (“Diver Down”) flag be displayed. This is a red flag with a white diagonal stripe running from the upper corner of the hoist to the lower opposite corner.
- (4) In addition, when submersible operations are conducted, “November Echo 2” shall be displayed.

BY DAY, WHEN DIVING OPERATIONS ARE IN PROGRESS, THE DIVING SUPERVISOR ENSURES THE DEPLOYMENT OF APPROPRIATE SIGNALS, AS FOLLOWS:



- (1) CODE ALPHA VISIBLE ALL AROUND THE HORIZON AND NOT LESS THAN 1 METRE ABOVE THE WATER LINE.

SMALL CRAFT NEED ONLY DISPLAY A RIGID REPLICA OF CODE ALPHA.



- (2) IN ADDITION TO CODE ALPHA, IN WATERS WHERE MERCHANT TRAFFIC MAY BE ENCOUNTERED, THESE SHAPES (BALL, DIAMOND, BALL) IN A VERTICAL LINE WHERE THEY CAN BEST BE SEEN.



- (3) "DIVER DOWN" FLAG, IN ADDITION TO SIGNALS ABOVE, IN AREAS WHERE PLEASURE CRAFT ARE OPERATING.

Figure 1-10 Diving Warning Signals (DAY)

b. **By Night**

- (1) **Small Craft.** Three lights in a vertical line. The highest and lowest of these shall be red, and the middle light shall be white. They shall be visible around the horizon at a distance of at least 3.7 km (2 NM).
- (2) **Other Vessels.** Lights prescribed in the current Transport Canada/Transports Canada Collision Regulations.

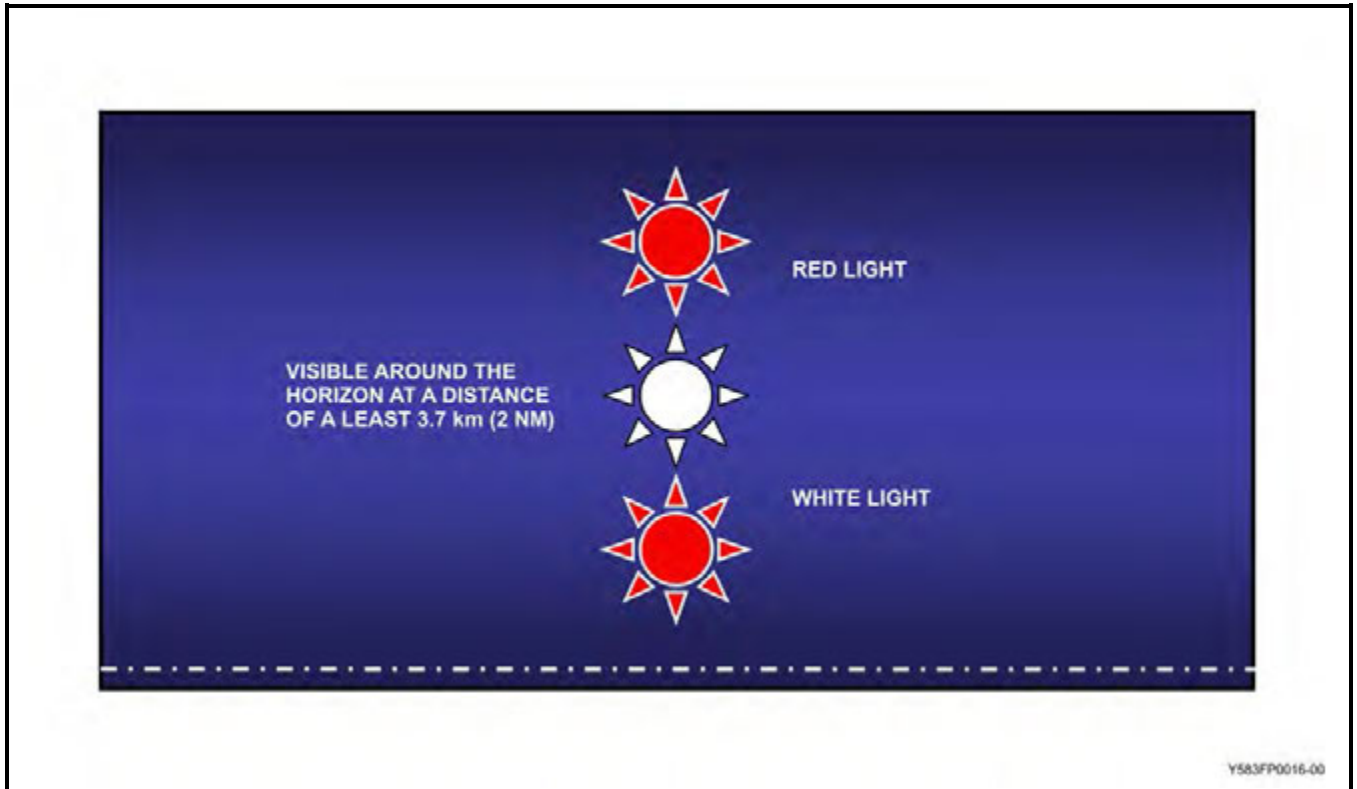

Figure 1-11 Diving Warning Signals (Small Craft, NIGHT)

148. COMMUNICATIONS WITH SWIMMING DIVERS

1. Manual Line Signals

- a. In the absence of any alternative method, manual signals by line are employed for all communications where two divers or a diver and an attendant are in contact by lifeline.
- b. Manual line signals are of two kinds:
 - (1) **PULLS**Long, steady and distinct pulls.
 - (2) **BELLS**Short, sharp pulls made with the same timing as striking a ship's bell.
- c. All signals are to be preceded by one pull to attract attention.
- d. All signals received must be acknowledged by repeating the signal (but only if the signal is clearly understood).
 - (1) If a signal is not acknowledged or is acknowledged incorrectly the person making the signal shall repeat it until a correct acknowledgement is received.
 - (2) When a signal is being acknowledged incorrectly the Diving Supervisor may decide to surface the diver to clarify the situation.

- (3) It must be remembered that a diver at work may not always be able to acknowledge a signal immediately; the attendant must wait a few moments before repeating the signal.
- e. If the lifeline becomes fouled, it may be impossible to get signals through. The lifeline shall be unfouled immediately. When the Diving Supervisor has decided that the use of lifelines is required and it is the only form of communication with the diver, loss of such communication should be considered an emergency (refer to [Article 222](#)).
- f. Particular care should be taken when diving in deep water or strong tides to ensure that the utmost clarity in the transmission of signals is achieved. The ability to make and interpret signals in such conditions must remain largely a matter of experience.
- g. Manual line signals for diving are shown in [Figure 1-2](#).
- h. Supplementary signals in addition to those listed in [Figure 1-12](#) may be arranged between the Diving Supervisor and the diver to take care of special circumstances as they occur.

2. Additional Signals

- a. Unless through-water communications are available, communications during free-swimming operations are extremely limited.
- b. Sound signals are used from the surface control position and can be made by tapping on the diving ladder or on the ship's hull, or by underwater explosions using the Divers' Signal Recall or authorized Electronic Diver Recall.
- c. In addition to the hand and special signals shown in [Figure 1-12](#), a diver at night shall display a diver's indicating light (refer to [Article 428](#)) and when surfacing at night and requiring assistance shall switch on a strobe light (refer to [Article 429](#)).
- d. When **urgent assistance is required**, the appropriate end of the day/night distress flare is to be actuated.
 - (1) RED FLARE is to be displayed at night; and
 - (2) INTERNATIONAL ORANGE SMOKE is used during daylight.

149. COMMUNICATIONS AT THE DIVE SITE

1. One of the Supervisor's primary responsibilities is to ensure that clear communications are maintained at all times between members of a diving team. Both safety and the successful completion of the task demand that all team members are able to understand and respond to instructions. Equipment failure, noisy environments and other difficulties can result in a communications breakdown.
2. Similarly, since divers from different nations or linguistic groups under certain conditions may be permitted to dive in a CAF diving team, language capabilities must also be carefully considered. [Article 223](#), *Lost Diver*, and [Figure 2-1](#), *Diving Emergency Procedures* refer to lost communications. Other volumes of the CAF Diving Manual contain specific communications details and SOPs, and are also subject to the principles outlined in this Article.
3. Divers must be able to communicate their situation effectively to the Supervisor, standby diver and other team members. Additionally the dive team must be able to effectively communicate with their Command and emergency services from the dive site, particularly in remote locations. In an emergency clear and timely communications can mean the difference between life and death.
4. If the Supervisor is not fully satisfied that effective team communication is possible for either equipment or language reasons, the task shall be terminated or the diving roster re-organized.
5. Due to the potentially fatal consequences of ineffective communications, command should be informed of the circumstances and the actions taken by the Supervisor. They should initiate administrative corrective action as required.

DIVING DISTRESS SIGNALS

2 – PULLS / 2 – PULLS / 2 – PULLS I am fouled and need the assistance of another diver.

SERIES OF SINGLE PULLS

(not necessarily preceded by one pull) EMERGENCY! HAUL ME UP!

This signal is not to be answered, but is to be obeyed IMMEDIATELY.

It is used only in great emergency.

DIVING SIGNALS

DIVER to ATTENDANT

- 2 – PULLS Lower me. / Give me slack.
- 3 – PULLS Take up my slack.
- 4 – PULLS Haul me up.

ATTENDANT to DIVER

- 1 – PULL To call attention / Are you all right? / Interrogative
- 2 – PULLS ... ON DESCENT Stop going down.
ON ASCENT Stop coming up. You have come up too far. Go down until stopped.
- 3 – PULLS Stand by to come up.
- 4 – PULLS Come up.
- 4 – PULLS / 4 – PULLS Come up. / Hurry up.

DIVER to ATTENDANT / ATTENDANT to DIVER

- 1 – PULL I am all right. / Call attention. / Made bottom. / Left bottom. / Interrogative.
- 2 – PULLS / 1 – PULL Send down a rope's end (or as previously arranged).
- 2 – PULLS / 2 – BELLS Disconnect lazy shot from the shot line.

DIRECTION / SEARCHING SIGNALS

- 1 – PULL Search where you are.
- 2 – BELLS Go to end of your distance line (or jackstay).
- 3 – BELLS Go to your RIGHT.
- 4 – BELLS Go to your LEFT.
- 5 – BELLS Come in (or if on jackstay, turn back).

NOTE The diver shall face the lifeline and then go in the direction signaled, e.g. right or left.

WORKING SIGNALS

- 1 – PULL Hold on. / Stop.
- 2 – BELLS Lower.
- 3 – BELLS Pull up.
- 5 – BELLS Have found / started / finished my work.

HAND & SPECIAL SIGNALS

- THUMBS UP I am OK.
- HANDS WAVED ACROSS FACE I am in trouble.
- ONE DIVER RECALL SIGNAL EXPLODED U/W OR ONE PING FROM AN AUTHORIZED ELECTRONIC DIVER RECALL All divers surface immediately.
- HAND DRAWN ACROSS THROAT Out of air.
- CLENCHED HAND ON CHEST Low on air.
- POINT TO MOUTHPIECE Buddy breathe.

Y583FP0017-00

Figure 1-12 Manual Line Signals/Hand and Special Signals for Diving

ADMINISTRATION AND MEDICAL RECORDS

150. DIVING ADMINISTRATION

1. CAF Diving DAODs are the primary administrative orders dealing with CAF diving organization, responsibilities and administrative procedures. In the event of any discrepancy between CAF Diving DAODs and this manual, CAF Diving DAODs shall have precedence.

151. DIVING ALLOWANCE

1. Subject to any limitations prescribed in orders issued by the Chief of the Defence Staff, any individual qualified in any of the categories of diver shown in [Figure 1-1](#) is entitled to a diving allowance as prescribed in CBI 205.34, Diving Allowance.

152. MEDICAL, DENTAL AND PHYSICAL FITNESS REGULATIONS

1. All CAF divers and diving candidates shall be medically examined IAW CFHS Order 4000-04, Shallow Water Divers Periodic Health Assessment and Medical Administration Instruction.

2. All CAF divers require an annual dental examination.

3. On first selection for training in diving, candidates shall meet the standard as defined in CFHS Order 4000-04. The medical examination shall be conducted by a qualified Diving Medical Officer or a Medical Officer appointed by the Command Surgeon.

4. Complete medical examinations shall be conducted every two years for all divers with a screening examination in alternate years. The one exception to this rule is that divers actively involved in saturation or experimental diving must complete a medical screening provided by EDU Grp and signed off by an ADMO.

5. CAF Divers must meet the CAF fitness standard. Upon completion of testing, PSP staff or unit PA will record the results and sign the CF 849. Divers who fail are unfit diving until they pass the CAF Fitness standard.

6. All diving candidates shall undergo the prescribed tests IAW CFHS Order 4004-04 before commencing training and shall not undertake any diving if they fail to pass.

7. A diver whose examination for dental or physical fitness has passed the one-year anniversary date may be permitted to continue diving, provided it has been verified by a unit PA that no ongoing dental or physical fitness problems exist. This option shall only be considered when factors beyond the member's or unit's control have resulted in a delay in the scheduled examination. The duration of the extension, while at the discretion of the Commanding Officer, shall not exceed 6 months, and shall be noted in the diver's log on the appropriate pages. I.e. Physical fitness/Dental currency extended to (date of appointment within 6 months). This entry must be signed by Commanding Officer.

8. **MedicAlert® Tag**

a. The MedicAlert® tag is a warning device that indicates to others that the wearer may require special medical attention and ensures this condition is not aggravated by inappropriate first aid or medical treatment.

b. All divers shall be in possession of a MedicAlert® tag while diving and shall wear it for 24 hours after completing a dive using compressed air or gas. ADM(HR-Mil) INSTRUCTION 09/04 and CFHS Order 7100-01 gives details of procurement. The tag must read "SCUBA DIVER" or "DIVER" as appropriate.

9. In the event of a fatality resulting from a diving accident or incident, the post-mortem examination of the victim shall be conducted IAW CFHS Order 7100-01 (42-01), Annex C. This regulation also applies to drowning.

10. Before being returned to fit diving status following a medical restriction or hyperbaric treatment, the diver must be assessed by a medical authority as described at [Article 225](#) and the results annotated in the member's medical file.

153. CF 849 CANADIAN ARMED FORCES PERSONAL DIVING LOG

1. All CAF divers shall have a CF 849 (11-2005) Canadian Armed Forces Personal Diving Log to record required details of any dive or exposure to increased pressure.

2. Each entry in the diving log shall be signed by the Diving Supervisor and Diver.

3. The "MEDICAL EXAMINATIONS" page shall be completed and signed by the examining medical officer on each occasion the holder undergoes a complete diving medical examination (refer to [Article 152](#)) and screening medical every alternate year by a Diving Medical Physician Assistant (QL6B) or Diving Medical Officer (ensure log accompanies member to examination).

a. Delegation of authority to sign CAF 849 on behalf of the Diving Medical Officer:

(1) To prevent delay and ensure that the diver's log is current and available, a form letter, approved at 6600-1 (SURG GEN) 29 August 2000 (NOTAL), is authorized for use. The form letter is available from all RDCs, NAVRESHQ, CFSME (ADC) and FDUs. The following process is to be utilized to ensure that the diver's log is properly completed and the information is correctly filed:

(a) The form letter title "Delegation of Authority to Sign CF 849 On Behalf of Diving Medical Officer" is to be initiated by the diver's home Unit.

(b) The letter is to accompany the diver's medical documentation to the DMO.

(c) The DMO is to complete the form and return it to the diver's home Unit.

(d) The diver's Commanding Officer is to review the letter and enter the information in the diver's CF 849 and sign on behalf of the DMO.

(e) Copies of the completed form letter are to be held in the diver's medical and personal files.

(f) This process is not intended to replace the current method and when practical the diver should ensure that logs are signed by the examining DMO.

(2) Under exceptional circumstances a CO may sign the log on behalf of an MO in accordance with SURG GEN direction where no local DMO is available.

4. Naval Reserve personnel who, due to military requirements or geographical location, cannot complete their annual dental examination at a CAF Dental Clinic may have the examination conducted by a civilian dentist IAW NAVRESHQ: 6640-1(N51) 28 July 2005 (NOTAL). The civilian dentist may sign the CF 849 as the examining dental professional. A CAF dentist must review the results at the earliest opportunity.

5. Qualification courses are to be filled in by the instructor on successful completion of training.

6. Qualified divers are to produce their diving logs for verification and qualifications upon the request of the Diving Supervisor prior to diving or exposure to pressure.

7. Diving Supervisors shall NOT permit diving if a diver is out of date medically, dentally and/or physically.

8. See [Figure 1-13](#) for procedures and abbreviations used in completion of CF 849.

**PROCEDURES AND ABBREVIATIONS
CANADIAN ARMED FORCES PERSONAL DIVING LOG CF 849**

The following standard is to be used when filling out CF 849.

1. CAF 849 Personal Dive Logs must be quarterly reviewed and signed by CO or delegated dive officer / chief / senior diver and if delegated must be annually reviewed and signed by the CO.
2. All entries must be in blue or black non-soluble ballpoint ink (NOT pencil), with the exception of rescinded divers in which case red ink is to be used.
3. All boxes are to be completed. Ditto (“”) marks are NOT to be used.
4. Any blank lines are to be stroked through with a solid ink line.
5. All dives using service equipment will be defined as either operational, training or proficiency dives and will comply with rules and regulations contained in the CAF Diving Manual.
6. Recreational dives using civilian diving equipment shall be entered in the REMARKS column as “Civilian Recreational Dive”.
7. Medical examinations are to be entered by the Medical Officer (MO) conducting the examination (ensure log accompanies member to examination). However, a (QL6B) Physician Assistant (PA) may sign for an MO after reviewing the individual medical file.
8. The ID page information is to be completed and correct, showing surname, initials, service number, DOB, current rank (pencil), diver qualification, Unit (pencil), diver’s signature and photograph.
9. Approved fitness test results are to be entered by the evaluating person (ensure log accompanies member to testing).
10. Qualification courses are to be filled in by the instructor on successful completion of training.
11. All CAF divers shall retain their CF 849 for **5 years** after their final dive has been entered. For pension claims and other such purposes, it is recommended that the CF 849 be retained for life.
12. Use the instructions and abbreviations in [Figure 1-13, Sheet 2 of 2](#), in completing form CF 849 (CAF Personal Diving Log).

Figure 1-13 (Sheet 1 of 2) Procedures and Abbreviations, CF 849 (CAF Personal Diving Log)

**PROCEDURES AND ABBREVIATIONS
CANADIAN ARMED FORCES PERSONAL DIVING LOG CF 849**

DATE	Two digits indicating day of the month, month abbreviated to three letters and year indicated by four digits (e.g. August 3, 2006 is entered as 03 Aug 2006).
LOCATION	Location of the dive
EQPT USED	Compressed Air Breathing
AGA Mk II FFM	AGA Apparatus CABA
Canadian Clearance Diving Apparatus	CCDA Light-Weight Surface-Supplied Diving Equipment LWSSDE
Canadian Underwater Mine	Oxygen Rebreather S10
Countermeasures Apparatus	CUMA Recompression Chamber RCC
	Superlite SL17-B Helmet SL17
GAS MIX	60% O ₂ / 40% N ₂ 60/40
Compressed Air	C/A 40% O ₂ / 60% N ₂ 40/60
Oxygen / Helium mix	O ₂ He Oxygen O ₂
LEFT SURFACE (LS)	The local clock time as read on a 24-hr clock (e.g. 0800). Time is to be recorded in whole minutes as the diver leaves the surface.
LEFT BOTTOM (LB)	The local clock time as read on a 24-hr clock (e.g. 0800). Time is to be recorded in whole minutes as the diver leaves the bottom.
BOTTOM TIME (BT)	Numbers indicating the total time in minutes from when the diver leaves the surface to the time the diver leaves the bottom. Only actual BTs are recorded here.
REACHED SURFACE (RS)	The local clock time as read on a 24-hr clock (e.g. 13:00). Time is to be recorded as the diver reaches the surface and rounded up to the next whole minute.
TABLE	CAF Diving Table used for the dive.
D SCHED	Specified decompression procedure for a given combination of depth/bottom time as listed in a decompression table, i.e. Depth (msw)/BT (min).
DEPTH	Number indicating maximum depth in msw of dive.
TOTAL TIME OF DIVE (TTD) ...	Number indicating total time in minutes from when the diver leaves the surface to when the diver reaches the surface. Includes decompression time, travel time and any delay(s) on ascent.
SURFACE INTERVAL (SI)	Time (hr:min (00:00)) a diver has spent on the surface following a dive, beginning as soon as the diver surfaces and ending as soon as the diver starts the descent of the next dive.
REPETITIVE GROUP (RG)	A letter (A – O) relating to the amount of residual nitrogen in the diver upon surfacing after a dive.
REPETITIVE FACTOR (RF)	A two-digit number (1.0 – 2.0) relating directly to the RG and to the length of the surface interval after a dive. The RF is only required when repetitive diving is conducted.
TASK	Purpose/description of the dive task/mission.
SIGNATURES	Signed by Divers and by Diving Supervisor (name and rank).
TOTAL TIME TO DATE	Aggregate career diving time (hr:min) at the completion of that page.
TOTAL DIVES TO DATE	Aggregate of career dives at the completion of that page.

Figure 1-13 (Sheet 2 of 2) Procedures and Abbreviations, CF 849 (CAF Personal Diving Log)

**RECORD OF DIVING OPERATIONS
REGISTRE DES OPÉRATIONS DE PLONGÉE**

Date	Location – Lieu		Eqpt Used – Equip. utilisé		
Gas mix – M. gazeux	LS*	LB*	BT*	RS*	
Table	Schedule – Calendrier	Depth – Profondeur	TTD	SI*	RG*
Task – Tâche / Details		Position: Divers – Poste : Plongeur <input type="checkbox"/>		Standby – En attente <input type="checkbox"/>	Supervisor –Superviseur <input type="checkbox"/>
Divers – Plongeur / Signatures*		Sup Name / Rank – Grade* du sup		Sup Signature / Signature du sup	

Date	Location – Lieu		Eqpt Used – Equip. utilisé		
Gas mix – M. gazeux	LS*	LB*	BT*	RS*	
Table	Schedule – Calendrier	Depth – Profondeur	TTD	SI*	RG*
Task – Tâche / Details		Position: Divers – Poste : Plongeur <input type="checkbox"/>		Standby – En attente <input type="checkbox"/>	Supervisor –Superviseur <input type="checkbox"/>
Divers – Plongeur / Signatures*		Sup Name / Rank – Grade* du sup		Sup Signature / Signature du sup	

Date	Location – Lieu		Eqpt Used – Equip. utilisé		
Gas mix – M. gazeux	LS*	LB*	BT*	RS*	
Table	Schedule – Calendrier	Depth – Profondeur	TTD	SI*	RG*
Task – Tâche / Details		Position: Divers – Poste : Plongeur <input type="checkbox"/>		Standby – En attente <input type="checkbox"/>	Supervisor –Superviseur <input type="checkbox"/>
Divers – Plongeur / Signatures*		Sup Name / Rank – Grade* du sup		Sup Signature / Signature du sup	

Total Time to Date:
Temps total de plongées à ce jour : _____

Total Dives to Date:
Nombre total de plongées à ce jour : _____

Figure 1-14 (Sheet 1 of 6) Sample CF 849 (CAF Personal Diving Log)

MEDICAL EXAMINATIONS EXAMENTS MÉDICAUX				
Date	Results Résultats	Remarks Remarques	Location Lieu	Physician's Signature Signature du médecin

Figure 1-14 (Sheet 2 of 6) Sample CF 849 (CAF Personal Diving Log)

DENTAL EXAMINATIONS EXAMENTS DENTAIRE												
Date	Results Résultats	Remarks Remarques	Location Lieu	Dentist's Signature Signature du dentiste								

Figure 1-14 (Sheet 3 of 6) Sample CF 849 (CAF Personal Diving Log)

PHYSICAL FITNESS TEST TEST D'APTITUDE PHYSIQUE													
Date	Location Lieu	Type Nature du cours	Results Résultats	Signature									

Figure 1-14 (Sheet 4 of 6) Sample CF 849 (CAF Personal Diving Log)

COMMANDING OFFICER REVIEW PAGE PAGE DE RÉVISION DU COMMANDANT	

Figure 1-14 (Sheet 5 of 6) Sample CF 849 (CAF Personal Diving Log)

**PERSONAL DETAILS –
RENSEIGNEMENTS PERSONNELS**

Surname:
Nom de famille : _____

Initials:
Initiales : _____

Service Number:
N° de matricule : _____

DOB:
DDN : _____
(dd/mm/yyyy)
(jj/mm/aaaa)

Rank:
Grade: _____
*(In pencil –
Écrire au crayon)*

Qualification: _____
*(In pencil –
Écrire au crayon)*

Unit:
Unité : _____
*(In pencil –
Écrire au crayon)*

Signature: _____

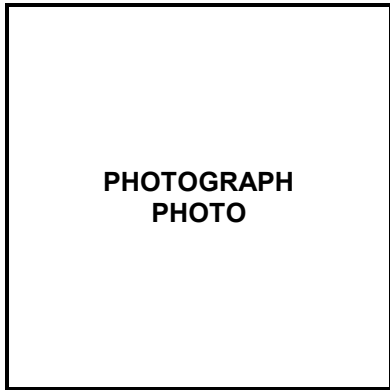

NOTE

Photograph may be a photocopy of the member's CAF identification card (NDI 20), a copy of the spare ID photo taken from the member's Unit Employment Record or Personnel File, or a locally produced digital photograph.

Figure 1-14 (Sheet 6 of 6) Sample CF 849 (CAF Personal Diving Log)

154. CANADIAN ARMED FORCES DIVING INFORMATION TRACKING SYSTEM (CAFDITS)

1. CAFDITS is used to track only military dives performed by a dive team as well as an individual diver's information such as qualifications, medicals, fitness tests, and waivers. CAFDITS centralizes dive and diver information, improves accuracy of data entry/retention and enables the generation of reports.
2. CAFDITS contains the Unit Diving Roster which includes; diver's name, rank, service number, dive qualification, qualification expiry, medical, fitness test, dental, last qualifying dive and remarks. All fields shall be kept up-to-date at all times.
3. A record of monthly diving activity shall be maintained using CAFDITS / CF 850, A hardcopy of monthly electronic CF 850 maintained, printed off and signed monthly by CO or as delegated to the Dive Officer/Senior Diver. If delegated, the monthly diving CF 850 reports must be reviewed and signed annually by the CO.
4. A quarterly diving report shall be maintained using CAFDITS a hard copy printed off, and signed by the CO or as delegated to Dive Officer/Senior Diver. If delegated, the quarterly reports must be reviewed and signed annually by the CO.
5. Diving activity by a diver from another Unit will be recorded in CAFDITS by the Unit conducting the dive.. Care must be taken to avoid reporting dive times more than once.
6. Ships/Units shall retain all printed and signed documents for a period of 5 years.

155. CF 377 CANADIAN ARMED FORCES COURSE REPORT

1. Form CF 377, Canadian Armed Forces Course Report, shall be submitted for all candidates who attend a diving course IAW instructions contained in DAOD 5031-9.
2. The necessary MITE input shall be actioned by the training establishment on successful completion of a diving course.
3. Candidates who successfully complete a diving course shall be given a Diving Qualification Certificate by the CAF diving training establishment conducting the training.

156. CF 777 UNSATISFACTORY CONDITION REPORT

1. Form CF 777, Unsatisfactory Condition Report (UCR) shall be submitted to identify deficiencies in material, policies and procedures, and identify potential and actual hazards to personnel, material, and property.

157. DIVING GENERAL MEMORANDA (DGM)

1. The prime purpose of DGM is to disseminate diving safety information quickly to all diving authorities and teams. Such information will normally consist of approved policy, procedures and regulations which have not yet been introduced into diving publications or which may be of a temporary nature.
2. DGMs are promulgated by D DIVE S under the authority of the Chief of Defence Staff. Administrative details are as follows:
 - a. **DGM Identification.** Each DGM will be numbered consecutively on an annual basis and given a short title for additional identification (e.g. DGM 2005/06/A, AGA Divers Mask – Safety Alert and Special Inspection).
 - b. **Action Addressee Indicator**
 - (1) A single letter “action addressee indicator” will be assigned to each DGM serial number to denote the particular diving units and teams affected by the DGM (e.g. DGM 2005/06/A, AGA Divers Mask – Safety Alert and Special Inspection).

- (2) DGM will be promulgated by message to one of six (6) AIG Action Addressee Indicator Lists (A, B, C, D, E and F) as follows:
 - (a) List **A** – AIG 1730 – CAF Diving Authorities and Diving Teams,
 - (b) List **B** – AIG 1804 – Naval Diving Authorities and Diving Teams,
 - (c) List **C** – AIG 1811 – Combat Diving Authorities and Diving Teams,
 - (d) List **D** – AIG 1829 – Search and Rescue Diving Authorities and Diving Teams,
 - (e) List **E** – AIG 1868 – Recompression Chamber Authorities and MCM Diving Teams, and
 - (f) List **F** – Limited Distribution (*list of classified DGM*).

c. DGM Indexing

- (1) D DIVE S will maintain the list of effective DGM, available at the D DIVE S website.
- (2) This list is to be inserted at the front of the individual DGM file to provide a ready-use index.
- (3) As subsequent DGM are promulgated, amendments are to be made to update the Unit's DGM index.

d. DGM Maintenance

- (1) In addition to specific action addresses received, a current file of all List A effective DGM is to be maintained by all AIG 1730 addressees (CAF Diving Authorities and Diving Teams).
- (2) DGM when received should be inserted into a protective loose-leaf binder and be maintained by the Unit Diving Officer or Team Supervisor when no Diving Officer is borne.
- (3) All DGMs shall be signed individually by each diver in the team ensuring the content is understood. DGMs shall be readily accessible and available for all personnel in a diving team.
- (4) DGM files are to be made available for examination during annual diving inspections.

158. DIVING TECHNICAL INSTRUCTION (DTI)

1. The primary purpose of the Diving Technical Instruction (DTI) is to quickly disseminate information to the Diving community of all diving technical defects/malfunctions or cautions of diving equipment used by CAF divers.

2. DNPS 6-4-2 is the OPI for DTI's and is responsible for the content, dissemination, follow-up and cancellation of all DTI's on the D Dive S Website. Diving Technical Instructions are issued for the use of all CAF military diving teams. A DTI includes: the known problem(s), the CAF unit(s) affected, the reference message advising of problem(s), detailed instructions to remedy the problem(s) and the contacts at DNPS 6-4-2 for queries. DTI's can be classified as an Electronic Technical Bulletin to the diving community.

159. DIVING SUPERVISOR'S NO-D LOG/WORKSHEET

1. A Diving Supervisor's No-D Log/Worksheet is to be maintained for all dives conducted in the CAF (see [Figure 1-15](#)).

- a. This activity commences at the start of every dive, as the Diving Supervisor is responsible for keeping an accurate record of dives in progress.
- b. The worksheet should be reproduced locally and is to be used for all CABA diving.

- c. The diver must sign the worksheet after each dive and the Diving Supervisor shall sign the bottom of the worksheet on completion of the dive(s).
- d. Ships/Units shall retain the worksheet for a minimum of 5 years.

160. ANNUAL DIVING INSPECTION

1. Annual technical and administrative diving inspections of all CAF diving units shall be conducted by D DIVE S with technical assistance from the Fleet Diving Units IAW CAF Diving DAODs.
2. The Annual Diving Safety/Administrative inspection will normally be conducted within one month of the 1 year anniversary of the previous inspection. Units shall request their annual safety/admin inspection by message to D Dive S no later than one month prior to the anniversary date of the previous inspection. If Units are unable to meet this requirement, then a formal request for extensions shall be forwarded to D Dive S.
3. If a Unit's dive team changes their status to "ineffective" (i.e. they are unable to conduct diving activities for an extended period of time), they shall advise D Dive S by message, info FDU and DNPS 6-4-2.
4. The Annual Diving Safety/Administrative checklist is available on the D Dive S website.
5. The Annual Technical Maintenance Inspection (TMI) checklist is maintained by the FDUs and is available on request.
6. D Dive S may grant an extension of up to six months beyond the anniversary of the last Safety/Admin Inspection, when justified by extenuating circumstances, such as operational deployment. Factors to be taken into consideration for requesting this waiver include:
 - a. Size and composition of dive team (e.g. number of dive supervisors, type of dive qualifications),
 - b. Proficiency of team (e.g. date of last dive, date of last requal, medical/dental/physical fitness to dive, number of divers on waivers from formation),
 - c. Date of last successful air sample and results of last dive safety/admin inspection.
7. Teams which have not had a D Dive S Safety/Admin inspection in an 18-month period shall be categorized non-effective until such time as the inspection is conducted. D dive S will promulgate status changes by message to appropriate chain of command.
8. Extensions more than one month past the anniversary of the previous TMI require the approval of DNPS 6-4-2, who will consult with D Dive S as required.
9. Diving operational readiness standards and practical diving evaluations are the responsibility of the respective chain of command.

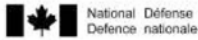

DIVING SUPERVISOR'S NO-D LOG / WORKSHEET

DATE _____ TASK _____ LOCATION _____ EQUIPMENT _____	SUPERVISOR _____ WEATHER _____ SEA STATE, TIDAL STREAM/CURRENTS, U/W VISIBILITY, HAZARDS _____ PLANNED SCHEDULE _____
---	--

Medical online ___ Task brief ___ Safety brief ___ Boat checked ___ Pers checked ___

Name	POSN	BAR/PSI	LS	LB	BT	D Sched	RS	DEPTH	TT	RG/RF	Signature

POSN: D = Diver; STBY = Standby Diver; DT = Diver Tender; BTOP = Boat Operator

REMARKS

EMERGENCY D/TIME RECORD – CF Tables 1 or 1S			
DEPTH	D/TIME	STOP WATCH	CLOCK TIME
MAX		LB	
1/2 MAX			
1ST STOP		ARR DEP	
2ND STOP		ARR DEP	
SURFACE		RS	
SCHED #1		SCHED #2	
Supervisor's Signature _____			

Figure 1-15 Diving Supervisor's No-D Log/Worksheet (to be reproduced locally)

DIVING ACCIDENT AND INCIDENT REPORTS, GENERAL PROCEDURES

161. NECESSITY TO REPORT

1. Considerable importance is attached to the study of accidents and unusual incidents experienced by divers in all types of diving equipment. The analysis of accurate data recorded shortly after an actual or simulated dive in which injury has occurred or could have occurred owing to failure of equipment or procedure is an important factor in the future safety of divers.

162. INCIDENT REPORTING

1. Serious accidents often result from the combination or interaction of numerous separate causal factors. Taken individually, they may seem unimportant, but the identification and elimination of these individual factors before they combine to cause an accident is nevertheless an important method of accident prevention.

2. All CAF diving units SHALL inform Director Diving Safety (D DIVE S) of any diving-related incidents experienced which could have led to an accident if undiscovered or left un-investigated, by plain language message and or by utilizing the CAFDITS Minor Incident Report, FAX or e-mail IAW Form No. 7 of the Diving Incident/Accident Report Forms.

- a. Informational copies of UCRs should also be sent to D DIVE S for inclusion in this database.
- b. D DIVE S will analyse these incidents and may promulgate information via the DGM format as required to advise other units of potential problem areas. Changes to procedures and/or equipment will also be disseminated.
- c. Dependent on the circumstances, D DIVE S may require the originator to submit a more complete report IAW [Article 164](#).

3. For purposes of safety only, D DIVE S will also accept anonymous information concerning diving-related incidents. This information will require independent confirmation before any action is taken. However, sources will not be divulged.

163. ACCIDENTS AND INCIDENTS

1. In the event of a diving accident or an incident, the Diving Supervisor is to take immediate steps to obtain the services of a Medical Officer if one is not already in attendance.

2. The Supervisor shall quarantine the equipment as detailed in [Articles 164](#) to [166](#).

3. Equipment should be sent to closest diving maintenance facility for further investigation by a qualified technician accompanied by Form No. 0 and Form No. 3.

4. Full explanations of other immediate actions are found in [Articles 164](#) to [166](#) and in [Chapter 2](#).

5. In the case of a serious accident occurring in Canada, the services of the Consultant in Diving and Hyperbaric Medicine located at Defence Research and Development Canada – Toronto (DRDC – Toronto) are available to advise on the recompression treatment or to correlate previous diving history with respect to recompression treatment ([Article 239](#)). Refer to [page i/ii, Diving Emergency Assistance/Medical Consultation](#), for contact information.

164. REPORTING OF DECOMPRESSION SICKNESS AND ALL DIVING ACCIDENTS

1. All diving and hyperbaric accidents require a report. This provides data for analysing the safety of decompression tables and the effectiveness of treatment procedures. It also supplies much valuable information on a variety of other diving hazards. Analysis of the reports is important in the continuous effort to improve diving practices and to increase diving safety generally.

2. The CAF Diving Incident/Accident Report Form (refer to Chapter 1, [Annex A1](#)), has been designed to assist in the collection of relevant data. For many incidents the report form will contain irrelevant questions, because it attempts to cover as many likely circumstances as possible. Any additional data that might have a bearing on an unusual incident should be included to fulfil the intent of the report.
3. A report in accordance with the CAF Diving Incident/Accident Report Form shall be initiated by the officer in charge of the operation for all cases arising from actual or simulated diving. Reporting of the following types of accidents is mandatory:
 - a. Death, or injury which entails more than a brief incapacity (refer to instructions in [Articles 167](#) to [171](#) for reporting and investigation of serious diving accidents);
 - b. Convulsions or serious impairment of consciousness during or after a dive;
 - c. Decompression illness of any kind;
 - d. Embolism;
 - e. Any serious mishap, even though the diver escapes actual injury, or
 - f. An incident that renders suspect any equipment or procedure.
4. To be of value, the facts must be established with care and recorded as soon after the accident or incident as possible, while memories are fresh. The report should include all details, however remote, that might have a bearing on the case. Speculation is not discouraged; however the originator should clearly indicate what is fact and what is opinion or suspicion.
5. CAF Diving Incident/Accident Reports shall be submitted in accordance with the detailed instructions on the reverse of the Top Sheet.

NOTES

1. In the case of a diving accident involving a civilian DND employee an extra copy is to be supplied to NDHQ/D DIVE S for onward transmission to Human Resources Development Canada, Occupational Safety and Health Division.
2. Medical reporting procedures are contained in CFHS Order 7100-01.
3. Whenever a CAF Diving Incident/Accident Report Form has been initiated arising from actual injury related to diving or the therapeutic treatment of a diver by use of a recompression treatment table, Form CF 98, Report of Injuries, shall also be initiated by the Officer in Charge and shall be completed IAW DAOD 5018-2 for all such cases.

165. INVESTIGATION OF LIFE SUPPORT EQUIPMENT AFTER A DIVING INCIDENT/ACCIDENT

1. When equipment is recovered after a diving incident, it is initially to be handled no more than is required to remove it from the diver and to examine it as described in [Article 163](#).
2. Without taking any action that may cause loss of gas from the cylinders, the examiner is to record the findings on the appropriate form set out in Chapter 1, [Annex A1](#).
3. If it is found that the accident has been caused by an obvious mechanical defect not connected with the breathing gas supply, the equipment is to be treated as indicated in [Article 163](#).
 - a. A copy of CF 777 (UCR) shall be forwarded with the report of the incident.

4. If the cause of the accident is not apparent, or if it may in any way have been caused by a defective gas supply (which may have resulted in an unexplained action by the diver), the breathing apparatus is to be sent to:

Defence Research and Development Canada – Toronto (DRDC – Toronto)
1133 Sheppard Ave. West
North York, ON, CANADA M3M 3B9

5. DRDC – Toronto is required to provide an accurate analysis of the gas supply by showing a specific breakdown with the percentages and concentrations of

- a. Major components,
- b. Any hydrocarbons in the sample,
- c. Water vapour, and
- d. Any other contaminants.

166. SPECIFIC ACTION TO BE TAKEN UPON RECOVERY

1. **CABA.** Isolate/quarantine cylinders by completing the following steps:

- a. isolate equipment;
- b. all valves found closed shall not be opened;
- c. the main cylinder supply valve is to be CLOSED;
- d. the Supervisor must record the number of turns required to close it;
- e. the position of the reserve valve is also to be noted and recorded;
- f. note and record any unusual equipment conditions;
- g. all quarantined equipment is to be securely bagged and sealed bearing in mind the requirement for preservation of evidence until further investigation can be completed by qualified personnel;
- h. The breathing apparatus is to be accompanied by gas samples from the storage cylinders used and or source, the samples being clearly marked to show their origin.

2. **AGA MK II FFM**

- a. Check and note the condition of the visor, head harness and equalisation device.
- b. Record the position of the gill valve (if applicable) and visually inspect the fittings of the intermediate pressure hose to mask, as well as all fittings on the second-stage regulator housing for obvious signs of improper connection or cross threading.
- c. Inspect oral/nasal mask and condition of one way valve.
- d. If a communications system was in use, its position and condition should also be noted.
- e. Except for visual inspection, the mask and regulator should not be disassembled in any way and should remain quarantined until inspection by qualified personnel.

3. **BDCMVBC**

- a. Check the BC for any rips, punctures, or obvious damage to the material. All straps, webbing and stitching must be checked for physical security or signs of failure.
- b. Without releasing the contents of the bladder, visually check all dump valves, the wash-out port and power inflator for physical security as well as for signs of damage.
- c. Condition of any accessory attached, as well as all attachment points, "D"-rings, etc., must also be recorded.
- d. Note status of weights.
- e. Except for visual inspection, the BC should not be disassembled in any way and should remain quarantined until inspection by qualified personnel.

4. **LWSSDE**

a. **Diving Console**

- (1) Record the pressure reading of all gauges and positions of all valves of the console.
- (2) Record number of turns to close all valves.
- (3) Visually inspect exterior of the panel.
- (4) Tape the regulator in position.
- (5) Secure HP supply and bleed down the umbilicals.
- (6) Cap or seal the umbilicals and console.

- b. **Umbilical.** The umbilical must be examined along its entire length for signs of damage or defects, taking note of the connection fittings.

- c. **Side Block Assembly.** Conditions of fittings and any visible or audible signs are to be recorded. The position of the emergency air valve is to be recorded as well as the number of turns required to close it.

d. **Emergency Cylinder**

- (1) The position of the emergency air cylinder valve is to be noted as well the number of turns required to close it.
- (2) If the emergency air cylinder is fitted with a reserve valve, its position must also be noted.
- (3) The first-stage regulator is to be retained with the Side Block Assembly (SBA).

- e. **Other Breathing Apparatus.** Other volumes contain instructions for examining the various other breathing apparatus used in the CAF.

INVESTIGATION OF SERIOUS DIVING ACCIDENTS

167. GENERAL

1. Diving is an inherently dangerous activity, requiring the use of complex equipment and procedures to mitigate the effects of a hostile environment in carrying out operational tasks. In many circumstances the margin of safety for the diver is small, and a procedural error or equipment failure can rapidly lead to injury or death. Consequently, it is expected that there will be diving accidents from time to time. A thorough understanding of the causal factors can reduce the frequency and severity of accidents, and may enable corrective measures to be developed. Experience gained in the investigation of safety issues in other hazardous environments has proven that an investigation oriented towards safety and prevention and not towards blame or the finding of individual responsibility is the most effective means of unearthing the causes, which can then be disseminated in the form of lessons learned. All aspects of the diving investigations dealt with under the authority of the CAF Diving Manuals adhere to this principle.

2. [Articles 161](#) to [166](#) detail generic procedures applicable in all instances of diving incident and accidents, regardless of severity. In addition, the actions outlined in the following Articles shall be adhered to with respect to all diving accidents involving death or serious injury.

168. INITIAL REPORTING

1. Following all diving accidents involving death or serious injury, in addition to the actions required in [Article 164](#), the Commanding Officer of the unit concerned shall:

- a. Contact the Canadian Armed Forces Integrated Command Centre (CAFICC) who will in turn notify Director Diving Safety (D DIVE S). An immediate verbal synopsis of the accident is required and the Accident and Incident Forms shall be used as a guide to the information to be obtained and provided to D DIVE S. This is to be done as soon as practical after the accident, but no longer than 24 hours after its occurrence. Form No. 7 is specially designed to recapitulate this initial verbal report in writing.
- b. Advise the Commander of the Formation, referring to this Section.
- c. Ensure NDHQ C NAVY OTTAWA and Director General Naval Strategic Readiness (DGNSR) are included as addressees on the initial Significant Incident Report and all subsequent amplifying reports.

2. The Commanding Officer shall also ensure appropriate, accurate and timely information is made available to next of kin (NOK). Failure to keep them well informed puts additional stress on NOK and creates suspicion.

169. FORMAL INVESTIGATION

1. All serious injuries and deaths in the CAF will normally result in either a Summary Investigation (SI) or Board of Inquiry (BOI); these will be conducted in accordance with the current instructions and directives contained in other publications.

2. In order to ensure appropriate technical expertise is available during the formal investigation, the composition of a Diving BOI shall be as follows:

- a. **President.** As nominated by convening Authority.
- b. **Member.** Qualified MARS 71D, preferably LCdr or above. D DIVE S should advise on selection.
- c. **Member.** Qualified Advanced Diving Medical Officer, who has completed Flight Surgeon principles of accident investigation training phase. NDHQ/C Navy RCN Surgeon or if unavailable the Consultant in Diving Medicine (CDM) at Defence Research and Development Canada – Toronto (DRDC – Toronto) should advise on selection.

- d. **Member Subject – Matter Expert (SME).** Normally a PO2 or above QL6B Clearance Diver who is current on all aspects of the type of operation and equipment involved. (Note: a second SME from the Combat Diving, SAR Diving, PID or JTF2 environment may be required to provide information on operations specific to those environments).
3. Witnesses and members of the BOI/SI shall be advised of the contents of [Article 170](#), particularly with reference to the privileged status of all statements made to D DIVE S.
4. As described in [Articles 165](#) and [166](#), diving equipment implicated in the accident must be quarantined immediately. For accidents involving serious injury or death, equipment is to be shipped under direction of D DIVE S to DRDC – Toronto, Attn: Experimental Diving Unit (EDU) by the most expeditious means. Warning labels are to be placed on the packaging advising that the shipment is evidentiary in nature and is to be handled only in accordance with current procedures applicable to ensuring continuity of evidence. In general this will require that only authorized personnel have access, detailed logging of all access and actions is taken, evidence is fully secured when not attended and a witness is on site during all handling and sampling. A message advisory must also be sent to DRDC TORONTO//EDU G// info NDHQ C NAVYOTTAWA//D DIVE S//. Test results reported by EDU G must form part of the proceedings of the SI/BOI if there is any question of equipment being a causal factor.

170. D DIVE S INVESTIGATION

1. As soon as practical after being informed of a serious accident, D DIVE S staff will travel to the accident location to conduct an independent safety investigation. A D DIVE S Investigation Tasking Message will be issued by C Navy or VCDS as required, containing the necessary details and authorities. If required, D DIVE S will contact DRDC – Toronto/CDM and request assistance. Once on scene, D DIVE S staff shall:
- a. Liaise with the Diving SI/BOI to review testimony to date and provide advice,
 - b. Interview personnel as required,
 - c. Assist CAF Public Affairs personnel as required in providing information to the media,
 - d. Brief appropriate Commanders as required, and
 - e. On completion of the on-scene assessment, take any action necessary to provide other CAF diving teams with safety or preventative information and direction.
2. The purpose of the D DIVE S safety investigation shall be the eliciting of causal factors. The investigation is to be focussed solely on determining these factors, making corrective recommendations and taking preventative actions as appropriate. Recommendations regarding disciplinary or administrative action against any personnel involved shall not be made. The findings of the D DIVE S safety investigation are not releasable to the BOI or SI since this could jeopardise the integrity of the former and greatly reduce the effectiveness of future D DIVE S safety investigations. Witnesses to the SI/BOI are to be so advised.
3. The Terms of Reference for the D DIVE S safety investigation should contain the following statement: “This D DIVE S safety/accident investigation enjoys the protection of Safety Officer/witness privilege. The proceedings of this investigation shall only be used for the purposes of accident prevention.” To encourage candour, witnesses are not to be questioned under oath.

171. DOCUMENTATION

1. As the prime purpose of this Section is to ensure that lessons learned from an accident are verified and disseminated to other operators as quickly as possible. It is vital that all documentation associated with diving accidents be expeditiously processed and forwarded.

2. Normally, the BOI/SI should render its report within 14 days of convening. The Convening Authority shall review the report and forward it with appropriate comments and recommendations to:
 - a. NDHQ/C Navy (via Commander of the Command if this is not MARCOM) within 14 days. Simultaneously, the convening authority is to send information copies of the report, including the Diving Accident and Incident Report Form, to:
 - b. NDHQ/D DIVE S for review and further action which may have been overlooked during their initial investigation; and DRDC – Toronto for review by EDU G and the CDM. If comment is warranted it shall be provided in writing to C Navy/ appropriate ECs (CAF, CLS, C Navy) within 30 days.
3. Appropriate ECs (CAF, CLS, C Navy) will correlate input from the Convening Authority, Command operational staff (C Navy/N52-2 DIVING and EOD), CAFHSG, DRDC – Toronto and AJAG, and prepare an Executive Summary of the accident for C Navy. The final version shall be forwarded to D DIVE S and ADM-Fin Corporate Services (Adm-Fin CS).
4. D DIVE S will produce a Closing Action Report, which will highlight the lessons learned and give direction as appropriate to ensure completion of action items. The Closing Action Report will be distributed within the CAF diving community and to other authorities, as required by the circumstances of the accident or death.

ANNEX A1

CAF DIVING INCIDENT AND ACCIDENT – REPORT FORMS

The following forms are to be reproduced locally as required for documenting diving accidents and incidents. An electronic version is available on the D DIVE S website.

THIS PAGE MUST REMAIN AS TOP SHEET.

**CAF DIVING INCIDENT/ACCIDENT REPORT
COVER SHEET**

THE ENCLOSED PROCEEDINGS/REPORTS OF A DIVING INCIDENT/ACCIDENT HAVE BEEN PREPARED UNDER AUTHORITY OF B-GG-380-000/FP-002 AND CONTAIN PRIVILEGED INFORMATION. THEY SHALL BE USED SOLELY FOR THE PURPOSES OF ACCIDENT PREVENTION AND ARE TO BE SEEN ONLY BY THOSE WITH A NEED TO KNOW.

THIS PAGE MUST REMAIN AS TOP SHEET.

**INSTRUCTIONS FOR USE OF
CAF DIVING INCIDENT/ACCIDENT REPORT
FORM NOS. 0 TO 7**

1. General instructions on the purpose and function of this reporting system are contained in [Chapter 1](#).
2. For cases involving death, serious accident or potentially serious incident the CO of the Unit conducting the dive shall send an unclassified Priority message to:
 - a. NDHQ C Navy OTTAWA//D DIVE S// and CFEME TORONTO//EDU GRP// and the appropriate administrative authority (refer to [Article 164](#) and Diving Incident/Accident Report Form No. 7).
 - b. Additionally, the CO's covering lettering for incident/accident reports must comment on the suspected cause of the incident and conclusions or recommendations that may help in determining required follow-up action. A guide for this is given in Form 1, Block C.
3. The CO of the Unit conducting the dive is responsible for originating and ensuring that forms are completed and distributed as follows:
 - a. For serious accidents/deaths, an advance copy of all relevant forms are to be sent directly to:
 - (1) NDHQ C Navy OTTAWA//D DIVE S//,
 - (2) NFR, and
 - (3) CFEME TORONTO//EDU GRP//.
 - b. When equipment is involved, Form Nos. 3(1), 3(2), 3(3), 4(1) and 4(2) are to be forwarded with the equipment to the Inspecting Authority.
 - (1) The Inspecting Authority will normally be FDU(A), FDU(P) or CFEME TORONTO//EDU GRP//.
 - (2) The Inspecting Authority will complete and return Diving Incident/Accident Report Form Nos. 4(1) and 4(2) to the originating CO for inclusion in the report.
4. When completing the CAF Diving Incident and Accident forms, all original statements and a clear certified true copy of the dive supervisor record sheet shall be forwarded to D Dive S. Diving Safety statement forms must remain separate and apart from the evidence which an SI or BOI may seek or obtain. When Diving Incident/Accident Report Form Nos. 0, 1, 2, 3 (3 sheets), 4 (2 sheets), 6 and 7 have been completed and compiled by the CO they shall be designated as PROTECTED "A" and sent to:
 - a. The diving OPI at their respective Formation and Command//OLHQ Headquarters,
 - b. NDHQ C Navy OTTAWA//D DIVE S//,
 - c. The addressees at [paragraph 5](#).
5. When Diving Incident/Accident Report Form No. 5 (4 sheets) is completed it is designated as PROTECTED "B" and sent to:
 - a. NDHQ/D DIVE S and NDHQ/Health Services Group,
 - b. CFEME TORONTO//CDHM//, and

- c. C Navy//RCN Surg// or CLS//Surg// or C AIR FORCE//Surg//.

NOTE

If the report involves a non-DND civilian, portions of the individual's personal identifying information may be omitted in order to respect privacy laws. All other details shall be included such that the report presents an accurate account of the events, injuries (if any) and subsequent treatment of the victim(s).

- 6. Instructions on review and follow-up are in CAF Diving DAODs.

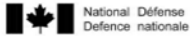

**DIVING LIFE SUPPORT EQUIPMENT FAILURE
INVESTIGATION REPORT**

0

1. Reporting Unit:	2. Point of Contact:	3. Date of Failure:
4. DTG of Initial Msg:	5. DTG of Msg advising of Shipment:	6. Date & CI Div Establishment Eqpt Sent to:
7. Failed Equipment:		8. Serial Number(s):
9. How Failure was Discovered: Pre Dive During Operation Post Dive Planned Maintenance Other (describe):		
10. Type of Failure: Malfunction Broken or Damaged Unknown Publication Error Other (describe):		
11. Suspected Cause: Normal Wear / Tear Human Error Unknown Design Flaw Other (describe):		
12. Impact on Operations (Scale of 1 - 10, 1 being "insignificant", 10 being "complete inability to meet op requirements"):		
a. on unit: 1 2 3 4 5 6 7 8 9 10 Comment: _____		
b. on CF: 1 2 3 4 5 6 7 8 9 10 Comment: _____		
13. Comments by Originating Unit:		
14. Date Received by CI Diving Establishment: By:		
15. Comments by CI Div Life Support Technician (including recommendations as appropriate):		
16. DTG/Date of Closure Report sent to Originating Unit/Info D Dive S:		
17. Date Received by D Dive Safety Staff:		
18. Comments:		
19. Disposition:		
<p>NOTES:</p> <ol style="list-style-type: none"> Original of this form to accompany equipment to CI Diving establishment. Copy to be retained by originating unit, and copy sent to D Dive S. All copies to be retained for 5 years. Originating unit is to sent priority message to appropriate CI diving establishment (info D Dive S) that this report has been initiated and that the equipment is enroute, with expected delivery date if known. If additional pages are attached, each shall be numbered and the total number of pages noted at block 13. 		

Y583FP0019-00

Figure 1A-1 CAF Diving Incident/Accident Report No. 0



DIVER / WITNESS STATEMENT

2

DIVER / WITNESS DATA			
Ship / Unit Address	Name	Rank	SN
Date of Last Dive	Diving Qualification	Date Qualified	Where Qualified
Function: ___ Diver ___ Tender ___ Witness ___ Buddy ___ Other (<i>explain</i>)			
STATEMENT			
Signature	Name	Witness to statement	
Date	Appointment	Name	Signature
<p>NOTES</p> <ol style="list-style-type: none"> 1. The statement should contain all information that you consider relevant to the incident/accident. 2. If there is insufficient space, continue on separate sheets, which should be suitably labelled and then attached hereto. 			

Y583FP0021-00

Figure 1A-3 CAF Diving Incident/Accident Report No. 2



EQUIPMENT CONDITION & ACTION ON CABA RECOVERY 3 (1)

DIVER DATA		Name	Rank
Date / Time of Incident / Accident			
Diver's Equipment (<i>describe</i>)			
GENERAL			
<i>Use N/A (not applicable) where appropriate. If NO, please explain.</i>			
Normal pre-dive checks complete?			
All equipment serviceable?			
Diver qualified in equipment?			
Only CF diving equipment used?			
COMPRESSED AIR BREATHING APPARATUS			
Main cylinder pressure at start of dive:			
Where filled:			
Verify and note SPG pressure at end of dive:			
Main/Reserve/Secondary cylinder pressures at end of dive:			
Main cylinder valve position:			
Number of turns to CLOSE:			
Emergency reserve valve position (up/down):			
BUOYANCY COMPENSATOR			
<i>If BC is inflated, seal relief valves and mouthpiece. DO NOT allow gas to escape or air to enter BC.</i>			
Power inflator connected?			
Status of all weights:			
WEIGHTS			
Weights in position?			
DRYSUIT			
Drysuit inflation hose connected?			
Drysuit exhaust valve status:			
AIR COMPRESSOR			
Date of last passed purity check:			
Running hours since last check:			
OTHER DATA			
<i>Include relevant details of other items of equipment, e.g. condition of harness, comms, position of air compressor intake. Also state all actions that may have affected the equipment after the accident, except as already noted.</i>			
Sealed and sent for inspection and analysis to:			
Signature	Name	Rank	
Appointment			Date

Y583FP0022-00

Figure 1A-4 (Sheet 1 of 3) CAF Diving Incident/Accident Report No. 3



EQUIPMENT CONDITION & ACTION ON CCDA / CUMA / S-10 RECOVERY

3 (2)

DIVER DATA		Name	Rank
Date/Time of Incident/Accident			
Diver's Equipment (<i>describe</i>)			
GENERAL			<i>Use N/A (not applicable) where appropriate. If NO, please explain.</i>
	Yes	No	
Normal pre-dive checks complete?			
All equipment serviceable?			
Diver qualified in equipment?			
Only CF diving equipment used?			
CCDA / CUMA / S-10			
<i>After noting the position of the mouthpiece lever, switch the lever to the ATMOSPHERE position immediately. DO NOT allow gas to escape or air to enter the counterlung. Seal the CRV with tape or similar method taking care not to alter the setting or to exhaust any gas from the counterlung. Disconnect CUMA LED cable to switch diagnostics off.</i>			
CUMA MANIFOLD O ₂ VALVE		BAILOUT CYLINDER VALVE	
Position:		Position:	
Note SPG pressure if OPEN:		Number of turns to CLOSE:	
Number of turns to CLOSE:		Gas supplier:	
% O ₂ in mixture:		Pre-dive pressure:	
Gas supplier:		Pre-dive flowrate:	
Pre-dive pressure:		Setting:	
CUMA DILUENT VALVE		Date:	By whom:
Position:		BAILOUT QUARTER-TURN VALVE	
Note SPG pressure if OPEN:		Position:	
Number of turns to CLOSE:		BUOYANCY CONTROL VALVE (BCV)	
CCDA / S-10 METERING VALVE		Position:	
Pre-dive setting:		Number of turns to CLOSE:	
Date:	By whom:	CO ₂ CANISTER	
		Time filled:	
		Batch No.:	
		Supplier:	
OTHER DATA			
<i>Include relevant details of other items of equipment, e.g. condition of harness, comms, position of air compressor intake. Also state all actions that may have affected the equipment after the accident, except as already noted.</i>			
Signature		Name	Rank
Appointment			Date

Y583FP0023-00

Figure 1A-4 (Sheet 2 of 3) CAF Diving Incident/Accident Report No. 3



EQUIPMENT CONDITION & ACTION ON

3 (3)

SSDE / LWSSDE RECOVERY

DIVER DATA		Name	Rank
Date / Time of Incident / Accident			
Diver's Equipment <i>(describe)</i>			
GENERAL		<i>Use N/A (not applicable) where appropriate. If NO, please explain.</i>	
	Yes	No	
Normal pre-dive checks complete?			
All equipment serviceable?			
Diver qualified in equipment?			
Only CF diving equipment used?			
SSDS / RCC / LWSSDS			
Breathing Apparatus:	SUPERLITE		
Breathing Medium:	Steady flow valve position:		
Supplier:	Number of turns to CLOSE:		
Main bank pressure:	Dial-a-breath setting:		
Other bank pressure:	Number of turns to CLOSE:		
Bailout cylinder valve position:	Emergency valve position:		
Number of turns to CLOSE:	Number of turns to CLOSE:		
Bailout pre-dive pressure:	Last maintained by:		
Pre-dive checks performed by:	Date of last maintenance:		
	AGA / OTHER		
	Last maintained by:		
	Date of last maintenance:		
	Drysuit inflation hose connected?		
	Drysuit exhaust valve status:		
OTHER DATA			
<i>Include relevant details of other items of equipment, e.g. condition of harness, comms, position of air compressor intake. Also state all actions that may have affected the equipment after the accident, except as already noted.</i>			
Sealed and sent for inspection and analysis to:			
Signature	Name		
Appointment	Date		

Y583FP0024-00

Figure 1A-4 (Sheet 3 of 3) CAF Diving Incident/Accident Report No. 3



EQUIPMENT ANALYSIS REPORT

4 (1)

To be completed by the authorities responsible for the inspection and analysis of the equipment used during the dive (FDU or EDU).

DIVER DATA		Name:		Rank:		
Date / Time of Incident / Accident:						
A EQUIPMENT ANALYSIS CHECKLIST These lists are not comprehensive but are intended to ensure that the equipment is thoroughly inspected. Only applicable spaces need to be marked and blank spaces may be used as required. All UNSAT notations must be fully explained on SHEET 2, Blocks K and L. Details of action taken (letter/report/UCR) should be included if not already shown on Form 1, Block C.	D CCDA / CUMA / S-10		E SSDE / LWSSDE			
	<i>(cont'd)</i>		<i>(cont'd)</i>		SAT	UNSAT
	Backpack / fairing				Emergency supply valve	
	Selector valve (CCDA, S-10)				Emergency cylinder valve	
	Metering valve (CUMA)				Main exhaust valve	
	Regulator performance				Demisting channel	
	Flasks				Oral-nasal mask	
	Flask manifold (CCDA, S-10)				F DIVING DRESS	
	Flask valves (CUMA)				SAT	
	Bypass valve				UNSAT	
	HP & IP hoses				General condition	
	Canister connections				Neck seal / cuffs	
	CO ₂ absorbent				Valves – gas	
	Absorbent batch				Valves – hot water	
	B CABA		G ACCESSORIES		SAT	
	SAT	UNSAT		UNSAT		
Cylinders			Compass			
Regulator 1 st -stages			Depth gauge			
Hose			Watch			
Regulator 2 nd -stages			Knife			
Cylinder valves			Safety knife			
Cylinder air sample			Facemask (swimmers)			
Cylinder pressure			Fins			
Air bank sample			Boots			
BC Cylinder Harness			Backpack harness			
BC power inflator			Weights			
BC valves			Lifeline			
BC bladder			Lifeline harness			
C CABA / LWSSDE		D1 ONBOARD BAILOUT		H CHAMBER (RCC)		
	SAT	UNSAT		SAT	UNSAT	
List 'B' above			Cylinder pressure			
Surface console			Gas sample			
Regulator 2 nd -stages			Regulator/orifice/hose			
Umbilicals			Connection port			
Comms						
D CCDA / CUMA / S-10		E SSDE		J DIVE PLATFORM		
	SAT	UNSAT		SAT	UNSAT	
Counterlung			Mask / helmet			
Harness			Neck dam			
Weight pouches			Rear locking pin			
CRV			Neck clamp			
BCV			Spider strap			
Mouthpiece & hoses			Spider buckles			
Full facemask & strap			Comms fittings			
	<i>(cont'd)</i>		Comms function			
			Nose block device			
			Liner			
			Faceplate			
			Non-return valve			
			Steady flow valve			
			<i>(cont'd)</i>			

Y583FP0025-00

Figure 1A-5 (Sheet 1 of 2) CAF Diving Incident/Accident Report No. 4



EQUIPMENT ANALYSIS REPORT

4 (2)

To be completed by the authorities responsible for the inspection and analysis of the equipment used during the dive (FDU or EDU).

DIVER DATA		Name					Rank	
Date / Time of Incident / Accident								
K	EXPLANATORY REMARKS	<i>Explain all UNSAT notations from SHEET 1 and add any other equipment observations and all recommended corrective action.</i>						
UCR (CF 777) Action				Continue on separate sheet if required.				
L	SAMPLE ANALYSIS	Analysis of all samples which were marked UNSAT on SHEET 1						
Storage / Compressor Source	Sample Source	ppm						Odours & Contaminants
		O ₂	N ₂	Water vapour	CO	CO ₂	He	
CO ₂ Absorbent Type	Batch Sample Activity	Canister Sample Efficiency					Contaminants & Remarks	
Continue on separate sheet if required.								
Testing laboratory				Test date				
				Test time				
				Test place				
Reporting Chemist / Analyst / Officer					Appointment			

Y583FP0026-00

Figure 1A-5 (Sheet 2 of 2) CAF Diving Incident/Accident Report No. 4



MEDICAL REPORT

PROTECTED 'B' WHEN COMPLETED

5 (1)

To be completed by Diving Medical Officer or senior person present.

Subject Name		Rank
Date & Time of Incident/Accident	Date & Time of Examination	Date & Time of Treatment
		Treatment Number
HISTORY		
ALCOHOL use in last 24 hours	HYDRATION before dive	TEMPERATURE of diver during decompression
<input type="checkbox"/> None <input type="checkbox"/> 1 – 2 drinks <input type="checkbox"/> 3 – 5 drinks <input type="checkbox"/> 6 – 10 drinks <input type="checkbox"/> 10+ drinks	<input type="checkbox"/> Well hydrated <input type="checkbox"/> Normal <input type="checkbox"/> Mild dehydration <input type="checkbox"/> Moderate dehydration <input type="checkbox"/> Severe dehydration	<input type="checkbox"/> Shivering <input type="checkbox"/> Cold <input type="checkbox"/> Comfortable <input type="checkbox"/> Hot
FITNESS LEVEL	FATIGUE LEVEL before dive	BODY COMPOSITION
<input type="checkbox"/> Excellent <input type="checkbox"/> Average <input type="checkbox"/> Below average <input type="checkbox"/> Poor	<input type="checkbox"/> Well rested <input type="checkbox"/> Normal <input type="checkbox"/> Tired <input type="checkbox"/> Exhausted	<input type="checkbox"/> Lean <input type="checkbox"/> Average <input type="checkbox"/> Overweight <input type="checkbox"/> Obese
EXERCISE or WORK during 12 hours pre-dive	EXERCISE or WORK during dive	EXERCISE or WORK during 12 hours post-dive
<input type="checkbox"/> None <input type="checkbox"/> Light <input type="checkbox"/> Moderate <input type="checkbox"/> Heavy	<input type="checkbox"/> None <input type="checkbox"/> Light <input type="checkbox"/> Moderate <input type="checkbox"/> Heavy	<input type="checkbox"/> None <input type="checkbox"/> Light <input type="checkbox"/> Moderate <input type="checkbox"/> Heavy
TOBACCO USE	DIVING HISTORY	
	List all dives during the last 5 days including the incident dive. Note the dive profile, date and time of all dives.	
DRUGS		
List all drugs/medications taken during 24 hours preceding incident dive. List quantity and time taken.		
RELEVANT MEDICAL HISTORY		
(Loss of consciousness, convulsion, diabetes, lung injury, asthma, ears, sinuses, trauma, current infections, date, location, treatment and outcome of previous DCS, etc.)		

Y583FP0027-00

Figure 1A-6 (Sheet 1 of 4) CAF Diving Incident/Accident Report No. 5



MEDICAL REPORT

PROTECTED 'B' WHEN COMPLETED

5 (2)

To be completed by Diving Medical Officer or senior person present.

Subject Name			Rank				
SYMPTOMS		<i>Before treatment, fill in letters as appropriate for 1st, 2nd, 3rd and 4th symptoms</i>					
Symptom	Location	Side	Intensity	Type of Pain	Time of Onset		
1.	1.	1.	1.	1.	1.		
2.	2.	2.	2.	2.	2.		
3.	3.	3.	3.	3.	3.		
4.	4.	4.	4.	4.	4.		
<p>SYMPTOMS</p> <p>APain BFatigue CItching DRash EMoultling FEdema GNumbness HWeakness JParalysis KVisual changes MHearing deficit NSpeech difficulty PDizziness (vertigo) QNausea/Vomiting RHeadache SLOC TConvulsion UDyspnea VShock WOther</p>		<p>LOCATION</p> <p>AEars BEyes CNose DMouth ENeck FShoulder GUpper arm HElbow JForearm KWrist MHand NFingers PChest QUpper back RLower back SAbdomen TButtocks UGroin VHip (cont'd)</p>		<p>LOCATION (cont'd)</p> <p>WThigh XKnee YCalf ZLower leg AAAnkle BBFoot CCToes DDOther</p> <p style="text-align:center;">SIDE</p> <p>ALeft BRight CBilateral DNot applicable</p> <p style="text-align:center;">INTENSITY</p> <p>AMild BModerate CSevere DNot applicable</p>		<p>TYPE OF PAIN</p> <p>ADull BBurning CSharp DSqueezing ECramping FCrushing GAching HThrobbing JGrating KBoring MNot applicable</p> <p style="text-align:center;">TIME OF ONSET</p> <p>ADuring the dive</p> <p style="text-align:center;">After surfacing:</p> <p>B< 5 min C5 – 15 min D15 – 30 min E30 – 60 min F1 – 2 hrs G2 – 6 hrs H6 – 12 hrs J12 – 24 hrs K24+ hrs</p>	
PHYSICAL EXAMINATION		Sex	Age	Ht	Wt		
Respiratory rate		BP		Pulse	Temp		
General appearance							
Ears: _____ Left _____ Right		Lungs, CVS, Abdomen, Extremities					
0TM appears normal 1TM mildly injected 2TM moderately injected		3TM severely injected 4free blood in middle ear or perforation 5large perforation or destruction of TM					
NEUROLOGICAL EXAMINATION		(Glasgow coma score)		CEREBELLUM			
EYE OPENING	MOTOR	SPEECH		RIGHT	LEFT		
_____ None _____ To pain _____ To command _____ Spontaneous	_____ Flaccid _____ Abnormal extensor _____ Abnormal flexor _____ Localizing _____ Follows command	_____ None _____ Incomprehensible _____ Confused _____ Appropriate _____ Oriented '3		Norm	Abnorm		
				Finger / nose	Norm	Abnorm	
				Rapid hand flips	Norm	Abnorm	
				Heel shin slide	Norm	Abnorm	
				Romberg	Norm	Abnorm	
				Gait	Norm	Abnorm	

Y583FP0028-00

Figure 1A-6 (Sheet 2 of 4) CAF Diving Incident/Accident Report No. 5



MEDICAL REPORT

PROTECTED 'B' WHEN COMPLETED

5 (3)

To be completed by Diving Medical Officer or senior person present.

Subject Name		Rank	
CRANIAL NERVES		MOTOR	
Norm	Abnorm	0None 1Palpable contraction 2Movement 3Against gravity 4Weakness 5Full strength	
	Visual acuity (II)		
	Visual fields (III)	R	L
	Pupils equal (III)		
	Pupils reactive (III)		
	Ocular movement (III, IV, VI)		
	Nystagmus		
	Diplopia		
	Sensation forehead, cheeks, lower jaw		
	Clench teeth (V)		
	Furrow brow (VII)	Norm	Abnorm
	Shut eyes tight (VII)		
	Smile or grimace (VII)		
	Hearing (VIII)		
	Swallow (X)		
	Gag & palatal movement (X)		
	Shrug shoulders (XI)		
	Protrude tongue (XII)		
TENDON REFLEXES		0 - None 2 - Normal 4 - Clonus	
		Right	Left
			Biceps(C5 - 6)
			Triceps(C6 - 8)
			Brachioradialis(C7 - 8)
			Knee(L2 - 4)
			Ankle(L2 - S2)
		Up	Down
			Babinski(L2 - S2)
SENSATION		DERMATOMES	
List any deficiency to touch, pain, vibration or temperature.			
INVESTIGATIONS			
	Hb		
	Hct		
	WBC		
	Platelets		
	Other (glue, CO, alcohol)		
	X-rays		

Y583FP0029-00

Figure 1A-6 (Sheet 3 of 4) CAF Diving Incident/Accident Report No. 5



MEDICAL REPORT

PROTECTED 'B' WHEN COMPLETED

5 (4)

To be completed by Diving Medical Officer or senior person present.

Subject Name		Rank	
DETAILS OF POSITIVE FINDINGS			
DIAGNOSIS		TREATMENT TABLE USED	
Omitted decompression		CF TABLE 5	
DCS I		CF TABLE 6	
DCS II		CF TABLE 6 Modified	
Pulmonary overinflation		CF TABLE 6A	
AGE		CF TABLE 6A Modified	
CO poisoning		CF TABLE 7	
Crush injury		Other Treatment Table	
Cyanide poisoning			
Hypoxic wounds			
Gas gangrene			
Necrotizing soft tissue infections		ADDITIONAL TREATMENT USED	
Osteomyelitis		Oral fluids	
Radiation necrosis		IV fluids	
Compromised skin grafts or flaps		Oral glycerol	
Thermal burns		Steroids	
OUTCOME		ASA	
Complete resolution		Other	
Partial resolution			
No change			
Recurrence			
Symptoms progressed		DISPOSAL	
Fatal		FIT DIVING	
TREATED BY		FIT DIVING WITH RESTRICTIONS	
Diving Medical Officer (Advanced)		TEMPORARILY UNFIT DIVING	
Clearance Diving Officer		PERMANENTLY UNFIT DIVING	
Clearance Diving Technician		TREATING AUTHORITY	
Diving Medical Officer (Basic)		Name	
Other		SN	Qualification
		Signature	
Certify CF 98 completed IAW Article 165. _____			

Y583FP0030-00

Figure 1A-6 (Sheet 4 of 4) CAF Diving Incident/Accident Report No. 5

24-HOUR REPORT MESSAGE FORMAT**7**

GENERAL	Message required IAW B-GG-380-000/FP-002, Article 165.
ACTION ADDRESSEES	NDHQ C Navy/D Dive S, CFICC Ottawa Formation OLHQ Admin Authority
INFORMATION ADDRESSEES	<ol style="list-style-type: none"> 1. All 24-hr reports: NDHQ/D MIL E or DAR/ as appropriate and CFEME TORONTO//CDHM. 2. When equipment investigation is required: NDHQ/DNPS/DNR/DGNSR, CFEME TORONTO/EDU GRP, FDU closest geographically. 3. When specialist medical assistance is required: NDHQ C Navy RCN Surg and CFEME TORONTO//CDHM.
FORMAT	<p>Subj: DIVING ACCIDENT 24-HOUR REPORT Ref: B-GG-380-000/FP-002, Article 165.</p> <ol style="list-style-type: none"> 1. Type of occurrence. 2. Number and condition of personnel involved. 3. Equipment involved. 4. Date / Time / Location of occurrence. 5. Narrative: This must include a detailed description of the occurrence, including all known relevant facts. Also included should be a discussion of possible cause factors and corrective measures. Speculation is not discouraged, however, the originator should clearly indicate in the report what is fact and what is opinion or suspicion. Completeness, candidness and relevance are essential to a useful narrative. 6. Action taken. Information on administrative/disciplinary action is not required. Action taken to prevent/reduce recurrence is to be included. 7. Assistance required.
PRECEDENCE	The message is to be assigned PRIORITY or higher precedence.
CLASSIFICATION	The message may be unclassified unless information included would be prejudicial to the Service or individuals involved.
SIC	LOL

Y583FP0032-00

Figure 1A-8 CAF Diving Incident/Accident Report No. 7

ANNEX B1
DEFINITIONS, ABBREVIATIONS AND ACRONYMS

(Applicable to CAF Diving)

DEFINITIONS APPLICABLE TO CAF DIVING

Attendant

A Service member qualified in diving who keeps continuously in hand a lifeline attached to a diver or continuously watches a float or marker attached to a diver or swimmer.

Attended Diving

Diving in any equipment wearing a lifeline (or umbilical designed to serve also as a lifeline) and tended by an attendant.

Combat Diving

A swimming or diving activity carried out by combat divers in a tactical setting using underwater breathing apparatus.

Combat Swimming

A tactical operation in which swimmers do not use underwater breathing apparatus.

Current Diver

Qualified CAF diver, knowledgeable and who has dived with CAF diving equipment associated to qualification within the last 90 days.

Diving Cycle

A diving cycle includes all aspects associated with a complete diving evolution such as pre-dive preparations, dive brief, conduct of the dive, post-dive maintenance and debrief.

Float Diving

Diving in CABA wearing a lifeline secured to a float of sufficient buoyancy to support the diver(s) in their heaviest condition.

Free-swimming in Pairs (with Buddy Line)

Divers operating in pairs, unmarked and unattended, but attached to each other but with a supervisor and standby diver in the vicinity.

Free-swimming in Pairs (Without a Buddy Line)

Divers operating in pairs, unmarked and unattended and not attached to each other but with a supervisor and standby diver in the vicinity.

Free-swimming Solo

One diver operating unmarked and alone, but with a supervisor and standby diver in the vicinity.

“In-date” Diver

A Service member who possesses a CAF Diving qualification, who has completed an applicable diving medical, dental and authorised fitness test within the preceding 12 months and is a “Current Diver”. Evidence that a diver is “in-date” should be taken from the diver’s log.

DEFINITIONS APPLICABLE TO CAF DIVING (Cont)

Jackstay

A line, rope or wire used to guide divers in an underwater search.

Marked Swimming

Underwater swimming using fins and wearing a light line secured to a light marker at the surface. The line shall be of sufficient length to reach the maximum planned depth of water.

Marked Swimming in Pairs

Underwater swimmers operating in pairs, attached to each other by a buddy line with the lead diver wearing a light line secured to a light marker at the surface. The line shall be of sufficient length to reach the maximum planned depth of water.

Non-diver Attendant

A Service member not qualified in diving but fully conversant with the use of diving signals and the handling of a lifeline. Continuously keeps in hand a lifeline attached to a diver or continuously watches a float or marker attached to a diver or swimmer.

Omitted Decompression

The time omitted from decompression from the appropriate CAF Diving Table.

On Site

The proximity of a hyperbaric chamber that enables a diver to leave their last in-water stop (i.e. 9 msw or the bottom for No-D dives), surface and reach the first chamber stop within seven minutes.

Open Water Diving

Diving in waters in which the swell, wave height or state may cause difficulty to surfaced divers wearing breathing apparatus. It includes conditions under which the supervisor may lose sight of surfaced divers or have difficulty locating lost divers on the surface.

Proficient Diver

Qualified, knowledgeable and worked-up in a specific piece of diving equipment related to the diver's qualification (for CABA: a minimum of 1 dive and 6 diving cycles within the last 90 days).

Redundant Breathing System

A breathing system that functions independently from the primary system and may be used by the diver in emergency when the primary system has failed. Its use requires positive actions such as opening valves or switching mouthpieces or masks.

Reserve Breathing Supply

A portion of the breathing media available to the diver, which is mechanically kept in reserve and may be used by the diver in emergency when the primary supply is depleted. Its use requires a positive action such as opening a valve.

DEFINITIONS APPLICABLE TO CAF DIVING (Cont)

Search Group Swimming

Two or more divers engaged in searching, all of whom are attached to the same light line. Only search methods published in this manual are included under this term.

Standby Diver

A safety diver deployed as directed by the supervisor to render assistance to other divers. The Standby diver must be fully qualified in the equipment being used and to the maximum depth of the dive.

Standby Regulator

A CABA regulator equipped with one first-stage and two second-stages.

ABBREVIATIONS AND ACRONYMS APPLICABLE TO CAF DIVING

ABN	Abnormal	CDO	Clearance Diving Officer
ADC	Army Dive Centre	CEM	Chief Engineering and Maintenance
ADMO	Advanced Diving Medical Officer	CFTO	Canadian Forces Technical Order
AGE	Arterial Gas Embolism	CHS	Chief Health Services
AOO	Area of Operations	CJMCC	Canadian Joint Maritime Component Commander
ata	Atmosphere Absolute	CLS	Chief Land Staff
AUMB	Aerospace and Underwater Medical Board	C Navy	Chief of the Naval Staff
BA	Breathing apparatus	C Navy	Commander RCN
bar	SI unit of pressure (= 105 Pa, or 14.5 psi)	C Navy RCN Surg	RCN Surgeon
BC	Buoyancy Compensator	CNS	Central Nervous System
BDCMVBC	Black Diamond® Canadian Military Version Buoyancy Compensator	CO	Carbon Monoxide
BOI	Board of Inquiry	CO₂	Carbon Dioxide
BT	Bottom Time	COP	Contingency Operations Plan
CABA	Compressed Air Breathing Apparatus	CPR	Cardio-pulmonary Resuscitation
CAF	Canadian Armed Forces	CSA	Canadian Standards Association
CAFDITS	Canadian Armed Forces Diving Information Tracking System	CSG	Canadian Support Group
CAFFSAT	Canadian Armed Forces School of Survival and Aeromedical Training	CUMA	Canadian Underwater Mine Countermeasures Apparatus
CAFHSGD	Canadian Armed Forces Health Services Group Directive	D DIVE S	Director Diving Safety
CAFICC	Canadian Armed Forces Integrated Command Centre	D MIL E	Director Military Engineering
CAFPD	Canadian Armed Forces Publication Depot	DAODs	Defence Administrative Orders and Directives
C Air Force	Chief of the Air Force Staff	DAR	Director Aerospace Requirements
CANFLTLANT	Canadian Fleet Atlantic	DC	Decompression computer
CANFLTPAC	Canadian Fleet Pacific	DCDS	Deputy Chief of Defence Staff
CBI	Compensation and Benefit Instructions	DCS I	Decompression Sickness Type I
CBTO	Combat Diving Officer	DCS II	Decompression Sickness Type II
CBTS	Combat Diving Supervisor	DGM	Diving General Memorandum
CCDA	Canadian Clearance Diving Apparatus	DGMEPM	Director General Maritime Engineering and Program Management
CDHM	Consultant Diving and Hyperbaric Medicine	DGNSR	Director General Naval Strategic Readiness
CDM	Consultant in Diving Medicine	DHTC	Dwyer Hill Training Centre
		DMO	Diving Medical Officer
		DNPS	Director Naval Platforms and Systems
		DNR	Director Naval of Requirements

ABBREVIATIONS AND ACRONYMS APPLICABLE TO CAF DIVING (Cont)

DRDC--Toronto	Defence Research and Development Canada – Toronto (f/k/a DCIEM)	LWSSDE	Light-weight Surface-supplied Diving Equipment
DTI	Diving Technical Instruction	MARLANT	Maritime Forces Atlantic
DTR	Dive Team Resuscitator	MARPAC	Maritime Forces Pacific
EBT	Effective Bottom Time	MCDV	Maritime Coastal Defence Vessel
ED	Effective depth	MCM	Mine Countermeasures
EDUG	Experimental Diving and Undersea Group	MCW	Moderately Contaminated Water
EOD	Explosive Ordnance Disposal	MOS	Military Occupation Structure
EOR	Explosive Ordnance Reconnaissance	mpm	Metres Per Minute
EPs	Emergency procedures	MSEO	Marine Systems Engineering Officer
FDU	Fleet Diving Unit	msw	Metres of Seawater
FFM	Full Facemask	N₂	Nitrogen
Frag O	Fragmentary Order	NATO	North Atlantic Treaty Organization
GNCS	Group Navigation Control System	NAVORD	Naval Command Order
HCW	Heavily Contaminated Water	NDHQ	National Defence Headquarters
He	Helium	NFR	Naval Fleet Requirement
HHG	Health Hazards Group	No-D	No Decompression
HP	High pressure	NOK	Next of Kin
HQ	Headquarters	NOR	Normal
HW SUIT	Hot Water Suit	O₂	Oxygen
IAW	In Accordance With	OCI	Office of Collateral Interest
ID	Identification	OJTs	On-the-job Training
IP	Intermediate Pressure	Omitted-D	Omitted Decompression
ITMIS	Individual Training Management Information System	OOW/OOD	Officer of the Watch/Officer of the Day
JOA	Joint Operations Area	OP O	Operations Order
JSG	Joint Support Group	OPI	Office of Primary Interest
JTF	Joint Task Force	OPLAN	Operations Plan
km/h	Kilometers Per Hour	OPSEC	Operations Security
kPa	Kilopascals	OS	Ordinary Seaman
LB	Left Bottom	OTV	Overtaken Vessel
LMDE	Limpet Mine Disposal Equipment	PA	Physician's Assistant
LOC	Lines of Communication	PA	Public Affairs
LP	Low Pressure	PAAC	Personal Auxiliary Air Cylinder
LS	Left Surface	PDR	Post-Deployment Report
LWSSACP	Light-weight Surface-supplied Air Control Panel	PFD	Personal Flotation Device

ABBREVIATIONS AND ACRONYMS APPLICABLE TO CAF DIVING (Cont)

PID	Port Inspection Diver	SME	Subject Matter Expert
POC	Point of Contact	SMM	Standard Manoeuvre Manual
POs	Performance Objectives	SSBA	Surface-supplied Breathing Apparatus
POS	Pulmonary Over Inflation Syndrome	STANAG	Standardization Agreement
ppm	Parts per Million	STBY	Standby Diver
ppN₂	Partial Pressure of Nitrogen	STD	Ship's Team Diver
ppO₂	Partial Pressure of Oxygen	STDO	Ship's Team Diving Officer
PTSD	Post-traumatic Stress Disorder	STDS	Ship's Team Diving Supervisor
QHM	Queen's Harbour Master	SUPLAN	Supporting Plan
QR&Os	Queen's Regulations and Orders for the Canadian Armed Forces	Sur D	Surface Decompression
RB	Reached Bottom	Sur DO₂	Surface Decompression With Oxygen
RCC	Recompression Chamber	TBT	Total Bottom Time
Recce	Reconnaissance	TDT	Total Dive Time
RF	Repetitive Factor	TF	Task Force
RG	Repetitive Group	TRSET	Transport and Rescue Standardization and Evaluation Team
RS	Reached Surface	TT5	Oxygen Treatment Table 5
SAAC	Survivor Auxiliary Air Cylinder	TT6	Oxygen Treatment Table 6
SAR	Search and Rescue	TUP	Transfer Under Pressure
SAT	Satisfactory	U/W	Underwater
SBA	Side Block Assembly, LWSSDE	UCR	Unsatisfactory Condition Report (CAF 777)
SCF	Standard Cubic Feet	UN	United Nations
SI	Summary Investigation	UNSAT	Unsatisfactory
SI	Surface Interval	VVDS	Variable Volume Drysuit
SI	Système Internationale (Metric System)	VV(s)	Valve(s)
SITREP	Situation Report	Wng O	Warning Order
SN	Service Number		
SOPs	Standard Operating Procedures		
SPG	Submersible Pressure Gauge		

ANNEX C1

ORDERS AND REFERENCE PUBLICATIONS PERTAINING TO CABA DIVING

A-MD-050-072/PW-001, Military First Aid Safety Oriented Book

A-PD-055-001/AG-001, Canadian Armed Forces Manual of Military Occupational Structure

ADIVP-1 (Navy), Allied Guide to Diving Operations

ADIVP-2 (Navy), Allied Guide to Diving Medicine

ATP-10 (D), Search and Rescue

B-GG-380-000/FP-001, Canadian Armed Forces Diving Manual, Volume 1, History, Physics and Physiology

B-GG-380-000/FP-002, Canadian Armed Forces Diving Manual, Volume 2, Organization, Regulations, Rules and Compressed Air Breathing Apparatus (CABA) Diving

B-GG-380-000/FP-003, Canadian Armed Forces Diving Manual, Volume 3, Surface-Supplied Diving Manual

B-GG-380-000/FP-004, Canadian Armed Forces Diving Manual, Volume 4, Self-Contained Mixed-Gas Diving, Book 1 of 3, Canadian Clearance Diving Apparatus (Version 2) (CCDA [V2])

B-GG-380-000/FP-004, Canadian Armed Forces Diving Manual, Volume 4, Self-Contained Mixed-Gas Diving, Book 2 of 3, Canadian Underwater Mine Countermeasures Apparatus (Version 2) (CUMA [V2])

B-GG-380-000/FP-004, Canadian Armed Forces Diving Manual, Volume 4, Self-Contained Mixed-Gas Diving, Book 3 of 3, S-10 Oxygen Rebreather Apparatus (S-10)

B-GG-380-000/FP-005, Canadian Armed Forces Diving Manual, Volume 5, Hyperbaric Chamber – Operation and Treatment Procedures

B-GG-380-000/FP-006, Canadian Armed Forces Diving Manual, Volume 6, Diving Supervisor’s Handbook (English)

B-GG-380-000/FP-007, Manuel de Plongée des Forces Armées Canadiennes, Volume 7, Aide-Mémoire du Superviseur de Plongée (Français)

B-GG-380-000/FP-008, Manuel de Plongée des Forces Armées Canadiennes, Volume 8, Organisation. Consignes. Règles et Appareil Respiratoire à Air Comprimé (ARAC) (Français)

B-GL-361-007/FP-001, Combat Diving

C-03-005-033/AA-000, Naval Engineering Manual, Part 17, Section 9 – “Compressed Air Systems”

C-87-010-010/MS-003, Operating and Maintenance Manual, Divers’ HP Air Compressor NSN 4310-21-869-3745 (Gasoline Engine-Driven) NSN 4310-21-869-3746 (Electric Motor-Driven)

C-87-010-011/MS-001, Care, Inspection, and Testing of Aluminium Diving Air Cylinders

C-87-011-000/TB-001, Divers’ Breathing Air Compressor Lubricating Oils

ORDERS AND REFERENCE PUBLICATIONS PERTAINING TO CABA DIVING (Cont)

C-87-020-001/NG-001, Special Test Instructions: Divers' Breathing Air Analysis

C-87-117-000/MS-001, Operating and Maintenance Instructions, YDT-11 Recompression Chamber, Fleet Diving Unit (Pacific)

C-87-167-000/MS-001, Operation and Maintenance Instructions, Hydraulic Divers' Tools

C-87-223-000/MS-000, Operating and Maintenance Instructions for the DUOCOM Transportable Recompression Chamber

C-87-226-000/MS-001, Operating and Maintenance Instructions, YDT-12 Recompression Chamber

C-87-229-000/MS-002, Operating and Maintenance Instructions, Mobile (SUBSAR) Recompression Chamber (Atlantic)

C-87-230-000/MS-002, Operating and Maintenance Instructions, Mobile (SUBSAR) Recompression Chamber (Pacific)

C-87-252-000/MS-000, Operating and Maintenance Instructions, Fleet Diving Unit (Atlantic) Main Recompression Chamber

C-87-276-000/MS-000, Operating and Maintenance Instructions, CFSSAT Recompression Chamber

C-87-273-000/MF-001, Maintenance Instructions, AGA Mk II Diving Mask, NSN 4220-21-903-1913

C-87-280-000/MS-001, Operating and Maintenance Manual, SUBSMASH Compressed Air Storage and Supply Unit

C-87-285-000/MF-001, Maintenance Instructions, Diver's SE-2/Arctic Regulator, NSN 4220-01-393-0750

C-87-286-000/MS-001, Operating and Maintenance Instructions, Light-Weight Surface-Supplied Diving System (LWSSDS)

C-87-287-000/MS-001, Operating and Maintenance Instructions, Fleet Diving Unit (Pacific) Main Recompression Chamber

C-87-303-000/MS-001, Operating and Maintenance Instructions for FDU(P) Main Diving Gas Supply and Distribution

C-87-304-000/MS-001, Operating and Maintenance Instructions for FDU(A) Main Diving Gas Supply and Distribution

C-87-325-A00/MS-001, Operating and Maintenance Instructions, Containerized Diving System Recompression Chamber

C-87-325-B00/MS-001, Operating and Maintenance Instructions, Containerized Diving System Workshop Container

C-87-356-000/ML-001, Operator's Preventive Maintenance/Service Instruction, Black Diamond® Canadian Military Version Buoyancy Compensator (BDCMVBC)

C-87-356-000/MS-001, Comprehensive Maintenance Manual, Black Diamond® Canadian Military Version Buoyancy Compensator (BDCMVBC)

ORDERS AND REFERENCE PUBLICATIONS PERTAINING TO CABA DIVING (Cont)

C-87-362-000/MS-001, Corrective Maintenance Instructions and Parts Lists for the Canadian Clearance Diving Apparatus (Version 2) (CCDA [V2])

C-87-363-000/MS-001, Corrective Maintenance Instructions and Parts Lists for the Canadian Underwater Mine Countermeasures Apparatus (Version 2) (CUMA [V2])

CAF Recreation SCUBA, CAF Sport and Recreational Diving Club Policy

CAF Scale D01-312, Personal Loan Issues to CAF Divers

CBI 205.34, Diving Allowance

CBI 205.345, Casual Diving Allowance

CFAO 55-10, Award of Special Badges

CFHS Order 4000-04, CAF Health Services Orders, Diver's Medical Standard

CFHS Order 7100-01, CAF Health Services, Osteonecrosis Survey

DAOD 5045-0, CF Personnel Support Programs, Interim Water Safety Policy

DAOD 8009-0 and 8009-1, CAF Diving

D-87-003-000/SG-001, Purity of Compressed Breathing Air and Gases for Divers

D-87-003-001/SF-000, Specification for Soda Lime used for the Removal of Carbon Dioxide in Underwater Breathing Apparatus

LMDE Addendum

NAVORD, Vol. 1, 9-12, Naval Reserve Diver Training

NAVORD, Vol. 1, 36-6, Diving and Air Material Supply Procedures

NAVORD, 46-500, Diving – Operational

NAVORD, 46-501, Diving – Training

1 CAD/TRSET, Standard Operating Procedures for Confined Space Rescue Diving, 2015-08-27

1 CAD/TRSET, Change 3, 2005-04-19, Guidelines for Survivor Extraction from Capsized Vessels

RCAF, Flight Operations Manual (FOM)

CHAPTER 2
EMERGENCY PROCEDURES
GENERAL

201. SCOPE

1. An emergency by definition is an unforeseen combination of circumstances or the resulting state that calls for immediate action. Because of the characteristics of the underwater environment, a situation that might only be annoying on the surface may assume life-or-death proportions for a diver.
2. By training and experience, the diver must be able to handle the wide range of actual and potential emergency situations that may be encountered. The diver must be able to separate the important from the trivial while at the same time recognizing the dangers that a seemingly minor symptom or event may foreshadow. The diver must be able to identify and properly react to the warning signals of various physiological disorders, whether affecting the diver or other divers. The diver must have a working knowledge of the most effective methods of handling physical emergencies (such as entrapment or malfunctioning equipment) as well as a basic knowledge of the correct steps to be taken in treating medical emergencies.
3. Most importantly, the diver must be able to work toward solving the emergency while under severe emotional and physical stress. Analysis of diving fatalities indicates that panic, or an inappropriate reaction to a relatively minor event such as a flooded mask, often triggers a sequence of events that leave the diver with a rapidly diminishing probability of survival. It is thus vital for divers to think through “what if” scenarios in advance. This will help to physically and mentally prepare them for an immediate and rational response.
4. Knowledge and training are vital. Individuals who are well-trained, well-rested, alert and confident can best cope with an emergency. An operation that is thoroughly planned, with a carefully paced workload and the prior organization of all necessary personnel, equipment and supplies, tends to be a safer operation. Equipment in good repair, properly maintained and not jury-rigged or “adapted” to a task is safer. Finally, while the environment of the dive cannot be directly controlled, it can be understood and any hazardous elements accommodated with special training, equipment or scheduling.
5. This chapter does not cover every possible situation that may cause problems for a diver, nor will it serve as a text on basic first aid. Other chapters of this volume cover operational hazards, general work procedures including some which apply in emergency situations and other publications present sufficient material on general medical procedures that this information need not be repeated here.
6. This chapter specifically details those emergencies that:
 - a. May be a matter of life or death,
 - b. Are unique to diving, and
 - c. May seriously interfere with the success of an operation.
7. **Diving Accident/Incident Reports.** The requirement to submit reports for diving accidents and incidents is covered in [Chapter 1](#). Specimen report forms may be found in Chapter 1, [Annex A1](#).
8. Further instructions that apply outside of Canada are contained in ADIVP1 (NAVY).

MEDICAL EMERGENCIES

202. IMMEDIATE ACTION

1. Divers who require emergency medical treatment fall into one of two categories:
 - a. Those who require recompression, and
 - b. Those who do not require recompression.
2. All members of the diving team should be able to make this differentiation and should have sufficient knowledge and training to proceed with appropriate treatment or corrective action. It may well be that no treatment would be the most appropriate course of action, especially by non-medical personnel. The first rule of first aid is to do nothing that will harm the patient. However, there are four medical conditions that must be treated immediately and cannot wait for the arrival of medical personnel.
3. Four immediate actions that must be taken, in order of priority, are:
 - a. Assure clear airway,
 - b. Restore breathing,
 - c. Assure heart function, and
 - d. Stop massive bleeding.
4. Following these four steps, a more thorough diagnosis of the problem can be made and the assistance of more qualified personnel obtained. A severely injured individual will be best served if the person helping protects the injured from further harm and strives to maintain stable breathing, heartbeat and blood circulation. Other treatment such as recompression may be concurrent with these procedures.
5. Recompression treatment is covered in Volume 5 of the CAF Diving Manual.
6. In-water recompression treatment is covered in this Chapter. Refer to [Article 228](#), *Omitted Decompression*.

203. MEDICAL EMERGENCY DURING A DIVE

1. In some serious situations (such as traumatic injuries occurring underwater) it may be necessary to bypass or delay normal decompression and risk decompression sickness in favour of rendering immediate first aid to the diver. Such serious situations can include:
 - a. Cessation of breathing,
 - b. Cardiac arrest, and
 - c. Massive haemorrhage.
2. Loss of consciousness is a serious situation and a complicating factor in any diagnosis. It can be the result of near-drowning, inadequate oxygen, an oxygen convulsion or an excess of carbon dioxide in the blood. In diving, loss of consciousness must be considered to be a symptom of arterial gas embolism (AGE) or decompression sickness (DCS). Recompression should be given in almost every case of unconsciousness simply because it is seldom possible to be certain that it is not a result of AGE or DCS. If satisfied that recompression is not called for in a given case, then treatment can progress along other lines as outlined in the following sections.

204. TREATMENT FOR SHOCK

1. Emergency treatment for shock is needed occasionally with underwater incidents. The procedure is as follows:

- a. Assure an open airway,
- b. Control haemorrhaging, and
- c. Control shock:
 - (1) Get the patient to relax in a comfortable position with the legs slightly elevated.
 - (2) Do NOT give pain-killing drugs or alcohol.
 - (3) If the patient is conscious and not nauseated, warm liquids may be given by mouth. Do NOT let the patient eat or drink if seriously injured, as this will increase the risk of vomiting if an operation is necessary.
 - (4) Loosen constrictive clothing at the neck and waist and wrap the patient in blankets, unheated and without a hot water bottle, to prevent a further loss of heat. The patient should be shaded from the sun and protected from breezes that may chill by evaporation. It is important not to overheat the patient, as this will cause the superficial blood vessels to dilate and draw blood away from the body core.
- d. Obtain medical assistance as soon as possible.

205. RESPIRATORY EMERGENCIES

1. All human life is directly dependent upon the quantity and quality of the breathing medium. Any deviations from established standards can result in a number of respiratory problems. In the underwater environment any such problem must be handled as an emergency.

2. Not all respiratory problems must result in termination of the dive. However, the need to ensure the safety of the diver will usually outweigh the operational requirement to complete the dive and the diver should be brought to the surface for treatment and thorough examination.

3. Every diver and every other member of the diving team must know the warning signs and symptoms for each of the following problems:

- a. Oxygen deficiency (hypoxia/anoxia) (Refer to [Article 207](#)).
- b. Oxygen poisoning (O₂ toxicity) (Refer to [Article 208](#)).
- c. Carbon dioxide poisoning (Refer to [Article 209](#)).
- d. Carbon monoxide poisoning (Refer to [Article 210](#)).
- e. Asphyxia (Refer to A-MD-050-072/PW-001).
- f. Strangulation (Refer to A-MD-050-072/PW-001).
- g. Chemical irritants (Refer to A-MD-050-072/PW-001).
- h. Nitrogen narcosis (Refer to [Article 211](#)).

206. POST-TRAUMATIC STRESS DISORDER (PTSD)

1. PTSD may affect divers following any serious diving accident or death and must be taken into account.

**SYMPTOMS AND TREATMENT
OF RESPIRATORY DISORDERS**

207. HYPOXIA AND ANOXIA (O₂ DEFICIENCY)

1. Definitions

- a. **Hypoxia.** A shortage of oxygen.
- b. **Anoxia.** A complete lack of oxygen.
- c. Both are generally caused by wrongly prepared equipment or incorrect drill.

2. Symptoms

- a. The diver may experience no symptoms but an observer might notice the following:
 - (1) Change of behaviour (diver becomes over-confident and nonchalant),
 - (2) Loss of judgment and efficiency,
 - (3) Dullness of senses,
 - (4) Restlessness and irritability,
 - (5) Loss of memory,
 - (6) Pallor of skin,
 - (7) Blueness of extremities,
 - (8) Increase of pulse rate, and/or
 - (9) Unconsciousness (with anoxia, a very rapid onset).

3. Treatment

- a. Treatment for either hypoxia or anoxia is as follows:
 - (1) Abort the dive.
 - (2) Surface slowly.
 - (3) Allow the patient to rest and breathe air or oxygen once out of the water.
 - (4) In serious cases administer artificial respiration.

NOTE

During recovery the patient may have mild convulsions.

WARNING

Breath hold diving preceded by extensive hyperventilation may cause a form of hypoxia. Artificially lowering the blood's CO₂ level by hyperventilation can mask the need to draw breath, thus allowing the blood's oxygen level to fall below that necessary to sustain consciousness.

208. OXYGEN (O₂) TOXICITY

1. **Cause.** Oxygen toxicity results from breathing oxygen at too high a partial pressure. Oxygen toxicity is highly unlikely in CABA at depths shallower than 60 msw, but may occur in RCC when breathing oxygen.

2. Symptoms

a. Symptoms of oxygen toxicity tend to vary from day to day and between individuals. The most frequent symptom is a grand mal convulsion with loss of consciousness. Other symptoms include:

- (1) Changes in vision such as blurring or narrowing of the visual field (tunnel vision),
- (2) Ringing in the ears,
- (3) Nausea/vomiting,
- (4) Vertigo/dizziness,
- (5) Twitching of the face and lips,
- (6) Tremors of the arms and legs,
- (7) Anxiety,
- (8) Confusion,
- (9) Malaise or excessive tiredness,
- (10) Uncoordination,
- (11) Numbness or tingling of the fingers or toes,
- (12) Fainting,
- (13) Spasmodic breathing,
- (14) Difficulty in taking a full breath or apparent resistance to breathing, and
- (15) Convulsions.

3. Treatment

a. Treat as follows:

- (1) If in the RCC, switch to air.
- (2) If in the water, do not change depth or surface during the rigid phase of convulsion (unless drowning).

- (3) Remove the breathing apparatus and suit and place the patient in fresh air to recover and
- (4) During convulsions, stabilize the diver sufficiently to prevent self-injury.

209. CARBON DIOXIDE (CO₂) TOXICITY

1. Causes

- a. Insufficient air being supplied to the diver,
- b. Incorrect or shallow breathing by the diver,
- c. Failure of the CO₂ absorbent system (not applicable to CABA),
- d. Contamination of breathing gases, and
- e. Over-exertion. Over-exertion increases CO₂ production and makes CO₂ build-up more likely.

2. Prevention

- a. Ensure proper maintenance of equipment (regulator performance and air quality),
- b. Ensure adequate ventilation,
- c. Avoid over-exertion, and
- d. Ensure that breathing is correct, i.e. long, deep breaths with all equipment.

3. Symptoms

- a. Breathlessness and panting,
- b. Dizziness, nausea, headaches, anxiety,
- c. General distress, sweating and palpitations,
- d. Loss of consciousness and/or
- e. Death.

NOTE

What is an acceptable proportion of CO₂ at atmospheric pressure can be lethal at depth. Loss of consciousness is often the initial symptom.

4. Treatment

- a. Treat as follows:
 - (1) On the bottom, relax and breathe deeply.
 - (2) Signal for more air according to the equipment in use. If this does not bring relief the diver must surface.

- (3) Give the diver oxygen or fresh air.
- (4) Allow the diver to rest. Recovery should be rapid. If not, obtain medical attention.

NOTE

The after effect of carbon dioxide toxicity may be a headache.

210. CARBON MONOXIDE (CO) POISONING

1. **Cause.** Carbon monoxide poisoning results from breathing impure air most likely contaminated by exhaust fumes when the cylinder was being charged.

2. **Prevention**

a. Adhering to the following can prevent carbon monoxide poisoning:

- (1) Always ensure that air intakes are upwind of exhaust fumes.
- (2) Avoid air intakes drawing air from inside compartments. Intakes should be sited outside in the open.
- (3) If stored in cylinders, breathing air must be obtained from authorized reputable sources.

3. **Symptoms**

a. Symptoms are similar to those of hypoxia, but also include:

- (1) Exhaustion with breathlessness,
- (2) A feeling of nausea,
- (3) Increasing weakness,
- (4) Dizziness and vertigo,
- (5) A pink colouration, otherwise skin pallor and/or
- (6) Loss of consciousness.

4. **Treatment**

a. Treat as follows:

- (1) Allow the patient to breathe 100% oxygen or fresh air.
- (2) Give artificial respiration if required.
- (3) An urgent consultation should be arranged with an ADMO or C/DM – or at any hyperbaric chamber.

211. NARCOSIS

1. **Cause.** Narcosis is caused because inert gases, especially nitrogen, become narcotic under pressure. The severity depends on depth (partial pressure).

2. Prevention

- a. Adhering to the following can prevent narcosis:
 - (1) Limit the depth of the dive.
 - (2) Deep divers should keep worked-up. This does not prevent narcosis but enables the diver to learn to partially control the effect.
 - (3) Dive using a less narcotic inert gas, such as helium (not applicable to CABA).

3. Symptoms

- a. Slurred speech,
- b. Irresponsibility,
- c. Inability to concentrate and
- d. Feeling of intense well being.

4. Treatment

- a. Decrease the depth of the dive.
- b. In serious cases bring the diver to the surface.

NOTE

Symptoms are similar to those of drunkenness. There is no danger from the narcotic effect itself. What are dangerous are the diver's consequent actions that may lead to injury or drowning.

**DIVING EMERGENCIES
WITH DIRECT MEDICAL INVOLVEMENT**

212. DISCUSSION

- 1. Emergencies discussed in this section are those which arise out of the nature of the diving environment: drowning, pressure imbalance and problems of low temperatures and heat loss leading to emergency conditions.

213. DROWNING/NEAR-DROWNING

- 1. Divers can drown because of over-exertion, panic, an inability to cope with rough water, exhaustion and/or the effects of cold water or heat loss. The prevention of drowning is best ensured by the establishment of, and thorough training in, safe diving practices coupled with the careful selection of diving personnel. A physically fit and confident diver equipped with proper gear should not easily fall victim to drowning.
- 2. To treat near-drowning:
 - a. Ensure airways are clear; if water is in mouth attempt to clear by rolling the casualty into recovery position and then back to supine.
 - b. Restore breathing and heartbeat; follow the most current CPR procedures.
 - c. Oxygenate; utilize the CAF Diving Team Resuscitator provided to every team.

- d. Remove wet or constricting clothing, wet suits/drysuits, etc.
- e. Alert, and seek assistance from, qualified medical personnel.
- f. Transport casualty to the nearest medical facility, noting that a recompression chamber may well be necessary.
- g. Regardless of the mildness or severity of a near-drowning case, all victims must be hospitalized as quickly as possible; follow-on lung failure and infection is possible in every near-drowning case.

WARNING

Drowning victims, especially if they are hypothermic may survive for unexpectedly long periods of time without breathing or blood circulation. Also, the victim's response to resuscitation is sometimes very slow and difficult to identify. In these instances death can only be confidently diagnosed after prolonged failure of sophisticated management by medical personnel using specialized monitoring equipment. Therefore it is essential that all personnel involved in first aid to drowning victims persevere with resuscitation – even when the situation appears hopeless – until the patient reaches definitive medical care.

WARNING

Regardless of the mildness or the severity of a near-drowning case, all victims should be hospitalized as quickly as possible. The occurrence of pulmonary edema (accumulation of fluids in the lungs), pneumonia and other complications may be delayed for many hours after the incident and proper medical observation is essential.

WARNING

While awaiting transportation to medical facilities the patient should be kept warm and comfortable.

214. SQUEEZE

1. Squeeze (barotrauma) is caused by a lack of pressure equalisation between the gas spaces in the body or between the body and the diving equipment. It normally occurs during descent. Squeeze may be categorised by location and cause as follows:
 - a. **Facemask Squeeze.** This is caused by a failure to equalize air in the mask by nasal exhalation. The eyes and eye socket tissues can be seriously affected.
 - b. **External Ear Squeeze.** May be caused by a hood or piece of equipment covering the outer ear, thus blocking the outer ear canal.
 - c. **Middle Ear Squeeze.** This is caused by a blocked Eustachian tube, increasing middle ear pressure relative to ambient pressure and bowing the eardrum, causing pain. This over-pressure can rupture the eardrum.
 - d. **Suit Squeeze.** This normally occurs in stiff drysuits in which a pocket of gas becomes trapped under a fold or fitting and pulls the skin into the fold area. Lack of suit inflation gas may lead to suit squeeze.

- e. **Body Squeeze.** This is caused by a failure of the gas supply to balance ambient pressure and helmet pressure when wearing a surface-supplied helmet. It can be precipitated by a fall into water of greater depth or by the malfunction or maladjustment of helmet supply and/or exhaust valves.
2. Squeeze may be relieved by the following procedures:
 - a. Stop descent.
 - b. If efforts to equalize pressure fail, ascend to shallower depth.
 - c. If further efforts to equalize pressure fail, abort the dive.
 3. If an eardrum rupture is suspected, send down the standby diver to assist. Dizziness and disorientation caused by a ruptured eardrum may expose the diver to further hazards, such as vertigo, vomiting, aspiration and in the worst case, panic ascent leading to death.
 4. If a diver suffers any physical injury, the diver must notify the Diving Supervisor and report to a Medical Officer for appropriate treatment.

215. HYPOTHERMIA

1. Immersion hypothermia (significant loss of body heat) is a potential hazard whenever diving operations take place in cool to cold waters. Hypothermia can be prevented by providing insulating garments, by limiting the duration of cold water dives and by re-warming the diver completely between dives. Adequate thermal support for divers is a necessity if operations are to proceed safely. A chilled diver must be brought out of the water before serious complications arise. Heat losses must be restored. Also refer to [Article 146](#).
2. Immersion in cold water may be immediately painful and distracting even before significant heat is lost. The hypothermic diver loses muscle strength and the ability to concentrate. The diver may be irrational or confused. Continued chilling can result in collapse, unconsciousness or death.
3. Diagnosis of hypothermia is easy if the condition is suspected but may be complicated by additional diving injuries. If the skin is cold the diver may shiver violently, and with severe hypothermia shivering may be replaced by muscle rigidity. Profound hypothermia may so depress heartbeat and respiration that the victim appears dead.
4. The treatment for hypothermia is re-warming. In mild cases when the diver is only chilled, treatment is still important if diving operations are to continue. Hypothermia severe enough to cause confusion or unconsciousness is a medical emergency. Do NOT wait on medical assistance before beginning re-warming. In profound hypothermia, even when it appears that breathing has stopped and there is no cardiac action, re-warming should be attempted only under specialist medical supervision.
5. The quickest and most efficient way to re-warm a conscious diver is with warm water, either in a bath or directed under the diver's suit. Rapid re-warming, if necessary, is best accomplished using water heated to 37 to 40°C. If hot water is not available, the next alternative is to dry the diver and provide warm clothes or blankets and a warm room or heat from another source.
6. A diver should be completely re-warmed before attempting a repetitive dive in cold water. Studies have shown that individuals suffering from heat loss invariably report feeling warm again very soon after they stop shivering, when re-warming is less than half complete. A simple indication that re-warming has been carried on long enough is the onset of sweating. In repetitive diving with exposure to cold, the operation should be planned so that the diver is re-warmed to the point of sweating before the next dive.

216. HYPERTHERMIA

1. Divers may easily succumb to hyperthermia (over-heating). Hyperthermia is potentially fatal, very difficult for the diver to detect and can lead to confusion and unconsciousness. Refer to [Article 145](#).
2. Some measures to prevent hyperthermia are:
 - a. Good hydration,
 - b. Rest,
 - c. Minimize exposure,
 - d. Positive cooling measures and
 - e. Selection of diving equipment.
3. Improved preventive procedures will be promulgated when available.

217. GAS EXPANSION

1. Occasionally a diver may experience various types of internal gas expansions. For example, in rare instances, a middle ear or sinus that has equalized pressure on descent may block on ascent, trapping a pocket of gas. Slowing the rate of ascent will usually permit the gas to escape without additional complications.
2. A more common condition results from the generation of gas in the intestines during a dive or from swallowing air that becomes trapped in the stomach. These pockets of gas will usually work their way out of the system through the natural vents. If not, and if the pain begins to pass the stage of mild discomfort, ascent should be halted and the diver should descend slightly until the pain is relieved. The diver should release the gas anally or attempt to belch, with the following caution: overzealous attempts to belch may result in swallowing more air.
3. Most intestinal gas expansion can be avoided by a few simple precautions: do not dive with an upset stomach or bowel, avoid eating foods that are likely to produce intestinal gas and avoid swallowing air during a dive.

218. BLOW-UP

1. Blow-up is defined as an uncontrolled rapid ascent caused by excessive positive buoyancy (usually due to over inflation of the diver's drysuit or BC). A diver should be aware that blow-up can lead to a number of serious problems, including gas embolism, decompression sickness and physical injury from collision with surface objects. Additionally, should the drysuit rupture from the high internal pressure, the diver can fall back to depth and be exposed to squeeze or drowning.
2. A diver should be particularly wary of the possibilities of blow-up when executing any manoeuvre that requires an increase in buoyancy, particularly if trying to free from a muddy bottom or in a similar situation where the diver is likely to break free suddenly.
3. The possibility of blow-up is also high when engaging in underwater jetting or tunnelling while using a drysuit. Stirred up silt or sand can clog the drysuit's exhaust valve resulting in a gradual and often unnoticed build-up of air in the suit. It is good practice to operate the exhaust valve at regular intervals to ensure that it is clear and working properly.
4. If caught in a blow-up, the diver must:
 - a. Breathe normally or exhale continuously to avoid embolism.
 - b. Attempt to vent air using the BC's manual dump valve or by using the drysuit sleeve.

5. When reaching the surface, vent enough air to prevent rupture of either the drysuit or buoyancy compensator while at the same time maintaining positive buoyancy. The attendant should take in any slack in the lifeline, get the diver out of the water and quickly examine the diver for signs of serious injury.

6. If the dive did not require decompression stops and the diver appears to be uninjured, ensure that the diver is closely watched and kept within one hour's travelling time of a hyperbaric chamber for a period of four hours.

7. If the dive required decompression stops that were omitted or if the diver shows any signs of decompression sickness or embolism, recompress the diver in a hyperbaric chamber at once.

8. If an RCC is not immediately available, transport the diver to the nearest chamber immediately using prescribed emergency procedures. Also refer to [Article 228](#), Omitted Decompression.

219. FOULING AND ENTRAPMENT

1. Divers must be particularly careful to watch not only their own lines but also those of other divers. Fouling and entrapment are more common with surface-supplied gear than with CABA because umbilicals can easily become entangled. Although the surface-supplied diver may become fouled more easily, the surface-supplied diver will also usually have an ample air supply while working to get free. This is not the case with the CABA diver.

2. If the diver is trapped, the possibility of running out of air before working free must be faced. If attempts to unfoul fail, the CABA diver should consider cutting/disconnecting a fouled lifeline. Ditch weights if required. Ditching gear and making a free ascent is a last resort.

3. The first and most important thing for a trapped diver to do is to stop and think. Remain calm, analyse the situation and carefully try to work out of it. Panic and over-exertion are the greatest dangers to the trapped diver and if a simple effort will not resolve the situation, GET HELP. Always keep in mind that the CABA diver can be given a new apparatus or be furnished with air by a buddy or the standby diver.

4. Once the diver has been freed and returns to the surface, examine and treat the diver with the following considerations in mind:

- a. The diver will probably be over-tired and emotionally exhausted.
- b. The diver may be suffering from, or approaching, hypothermia.
- c. The diver may have some physical injury.
- d. Decompression may have been omitted in which case recompression will be required.

220. EQUIPMENT FAILURE

1. Operational failure will rarely be a problem with good equipment that has been well maintained and thoroughly inspected and tested before each dive. When a failure does occur the correct procedure will depend upon the nature of the equipment and the dive. As with most emergencies, the training and experience of the diver and the diving team will be the most important factor in safely resolving the situation.

221. LOSS OF AIR SUPPLY

1. A CABA diver without air or with malfunctioning breathing apparatus should make a free ascent, remembering to exhale. If with a buddy, buddy breathe and ascend. Ascending while buddy breathing must be conducted with care since the possibility of embolism (due to breath holding) is increased.

2. **Buddy Breathing.** This is to be used only in an emergency when the diver cannot surface immediately and a new air supply is not readily available or is delayed. The out of air diver signals and swims toward the Buddy diver. The Buddy diver will face the out of air diver and provide the secondary air supply regulator (octopus) fitted to the BC. While the out of air diver breathes from the octopus, the Buddy diver takes positive control of the out of air diver by grasping the BC. Both divers should begin a controlled ascent to the surface to prevent injuries.

3. **Standby Breathing Assistance.** This will enable the standby diver to provide air to a stricken diver with greater efficiency and safety than by using the buddy breathing technique. Contact and control is maintained by the standby diver, who should take a position to best deliver the spare second-stage to the stricken diver (refer to [Article 413](#)). Both divers should swim to the surface breathing normally.

222. LOSS OF COMMUNICATION

1. Loss of communication between diver and attendant can be the first sign of serious problems. Additionally, because co-ordination between divers or between a diver and an attendant is interrupted, dangerous situations can rapidly develop, particularly when working with underwater tools and equipment. Refer to [Articles 435](#) and [436](#).

2. Correct procedures for the loss of communication are:

- a. Re-try line pull/diver recall/through-water signals at once, but keep in mind that because of depth, current, bottom or worksite conditions they may not always work.
- b. Check the diver's rising bubbles of air. Look for a cessation or marked diminishing which could be a sign of trouble.
- c. Send down the standby diver.

223. LOST DIVER

1. In planning for an operation using CABA, "lost diver" procedures must be included and understood by all personnel. ATP-10(C), Search and Rescue, [Chapter 6](#) contains pertinent graphs, diagrams and tables for calculating such factors as surface current caused by wind, efficient search methods and the probable area of the victim's location.

2. The first stage of a "lost diver" situation occurs when communications have been lost. The Diving Supervisor must IMMEDIATELY mark the position with the lost diver marker (refer to [Article 433](#)) and institute search procedures. At the same time, medical personnel should be notified and the hyperbaric chamber brought to IMMEDIATE NOTICE.

3. If the lost diver has become trapped or injured and the visibility is good, the diver should not be difficult to locate and assist. If visibility is poor the difficulty is greatly increased. This is one reason for the requirement that CABA divers be equipped with a buddy line or a surface-tended lifeline.

4. A lost diver is often one who has lost bearings and moved out of the operating area. The diver may be suffering from narcosis or a problem with the breathing mixture. This can result in mental confusion, disorientation, anxiety or panic. Unknowingly, a diver could harm those attempting rescue. When located, rescuers should approach cautiously to avoid being harmed while assessing the stricken diver's condition.

5. If the diver is unconscious when found bring the diver to the surface IMMEDIATELY.

- a. If possible, ensure the diver's head is held back to keep the airway open.
- b. Ascend SLOWLY. Rescuers should always remember the risk of embolism during ascent.

**DIVING
EMERGENCY PROCEDURES**

NOTES

1. Always remain calm.
2. **DIVER:** Continuously communicate (if possible) with topside or with buddy.
3. If ever in doubt, send down the standby diver.
4. **TOPSIDE:** Prepare for emergency recompression.
5. Check surfaced diver for injury.

NOTE

These following procedures are recommended as basic rules only. Not all situations will be the same.

Cause	Affected Personnel	Action
Fouling	Diver	<ol style="list-style-type: none"> 1. Move slowly and carefully. 2. Retrace steps to source of fouling. 3. If on lifeline, signal surface of condition and what you are attempting to do. 4. Consider cutting/disconnecting lifeline, ditching weights and conducting a free ascent. 5. For LWSSDE: Attempt to clear. If unable to clear, then signal surface, ditch weights, ditch mouthpiece and harness and conduct a free ascent.
	STBY diver	<ol style="list-style-type: none"> 1. At Supervisor's direction, check to see if the diver is all right. 2. If the diver conducts a free ascent, assist the diver. 3. Provide standby breathing assistance to the diver on ascent if the diver's equipment has been ditched.
	Supervisor	Prepare for recompression after medical check.
Traumatic injury while in-water	Diver	Reduce blood loss by applying pressure.
	STBY diver	<ol style="list-style-type: none"> 1. Improvise pressure dressing. 2. Assist diver in controlled ascent. 3. Be prepared to handle diver in shock.
	Supervisor	Treat diver for shock and blood loss.
Lost communication or lost diver	Diver	If separated from buddy or swim line, surface and indicate position.
	STBY diver	<ol style="list-style-type: none"> 1. If diver's air bubbles are visible, follow them. 2. If visibility allows, upon finding diver use hand signals to determine condition. 3. Assist diver to the surface.
	Supervisor	<ol style="list-style-type: none"> 1. If an attendant reports loss of communication, re-try available comms (line pulls/diver recall/through-water comms). 2. Mark area immediately with Lost Diver Marker. 3. Send standby diver out to trace diver's bubbles if visible. If not, follow diver's lifeline and mark area for search. 4. Fix location by all available navigational means and record data.

Figure 2-1 (Sheet 1 of 3) Diving Emergency Procedures

Cause	Affected Personnel	Action
Unconscious diver	Diver	Diver unconscious
	STBY diver	<ol style="list-style-type: none"> 1. Assist diver to the surface, removing weights if necessary. Support diver in head back position. 2. Inflate diver's BC.
	Supervisor	<ol style="list-style-type: none"> 1. Transport and recompress as soon as possible. 2. Monitor the diver for signs and symptoms.
Emergency ascent	Diver	<ol style="list-style-type: none"> 1. Ditch weights. 2. Inflate BC if necessary. 3. Make controlled ascent, exhaling continuously during ascent. 4. Activate day/night distress flare upon surfacing.
	STBY diver	Assist as directed.
	Supervisor	<ol style="list-style-type: none"> 1. If on lifeline, have attendant take up slack as diver ascends, but do not pull up the diver unless signalled for assistance. 2. Monitor the diver for signs and symptoms. 3. Prepare for recompression as required.
Delay or unplanned decompression	Diver	Ascend to pre-planned stop.
	STBY diver	Assist as directed.
	Supervisor	<ol style="list-style-type: none"> 1. Provide pre-planned stop depths. 2. Monitor dive profile. 3. Rig shot/lazy shot. Provide alternative air supply at pre-planned stops. 4. Prepare for recompression as required.

Figure 2-1 (Sheet 2 of 3) Diving Emergency Procedures

Cause	Affected Personnel	Action
Loss of air supply in LWSSDE	Diver	<ol style="list-style-type: none"> 1. Ensure umbilical is clear. 2. Open bailout bottle (if worn). 3. Ditch weights if necessary. 4. Inflate BC or drysuit to give positive buoyancy but do not over-inflate. 5. Make a controlled ascent.
	STBY diver	<ol style="list-style-type: none"> 1. Assist as directed. 2. Provide breathing assistance as required.
	Supervisor	<ol style="list-style-type: none"> 1. Direct standby diver to assist if necessary. 2. Have attendant take up umbilical slack as diver ascends. 3. Monitor the diver for signs and symptoms. 4. Prepare for recompression as required.

Figure 2-1 (Sheet 3 of 3) Diving Emergency Procedures

MEDICAL EMERGENCIES REQUIRING RECOMPRESSION

224. GENERAL

1. This section does not cover every possible situation that may cause problems for a diver, nor does it serve as a text on first aid. Volume 1 of the CAF Diving Manual covers diving physiology. Medical Emergencies, [Articles 202 to 206](#) provides information on first-aid, resuscitation techniques and control of bleeding.
2. This section specifically details the diagnosis of those emergencies that may require recompression treatment.
3. IF IN DOUBT, SEEK DIVING MEDICAL ASSISTANCE. Refer to [page i/ii, Diving Emergency Assistance/Medical Consultation](#).

225. ANCILLARY AND FOLLOW-UP TREATMENT

1. Divers who require recompression may or may not require emergency medical treatment. All divers should be able to make this differentiation and should have sufficient knowledge and training to proceed with appropriate treatment or corrective action. Refer to [Article 202, Immediate Action](#), for generic emergency treatment of divers. These procedures can be followed while preparing for a recompression treatment or may be performed in the hyperbaric chamber.
2. Before returning to fit diving status following a medical restriction or hyperbaric treatment, the diver must be assessed by a medical authority as described below :
 - a. **Non-pulmonary Barotrauma.** Cleared to dive by a PA or above and fit to return to diving when able to clear ears.
 - b. **Pinhole Tympanic Membrane Perforation.** Unfit for diving for a minimum of two weeks; must be cleared to dive by a hyperbaric-qualified PA, or a DMO or an ADMO.
 - c. **Major Tympanic Membrane Injury.** Unfit for diving until cleared to dive by an ENT specialist.
 - d. **DCS Type I.** Unfit for flying for 3 days; unfit for diving for a minimum of 7 days; must be cleared to dive by an ADMO or equivalent prior to diving.
 - e. **DCS Type II with Complete Resolution of Symptoms on First Treatment.** Unfit for flying for 7 days; unfit for diving a minimum of 30 days; must be cleared to dive by ADMO or equivalent prior to diving.
 - f. **DCS Type II with Residual Symptoms, or Requiring More Than One Hyperbaric Treatment.** Unfit for flying for 10 days; unfit for diving until case has been reviewed by DRDC Toronto/ Consultant in Diving and Hyperbaric Medicine (CDHM), after which clearance to dive must be given by an ADMO once DRDC Toronto/CDHM has concluded any necessary review or board.
 - g. **AGE with Complete Resolution of Symptoms.** Unfit for flying for 7 days; unfit for diving until case has been reviewed by CDM (Consultant in Diving Medicine) or AUMB (Aerospace and Underwater Medical Board). Prior to resuming diving, the diver must be cleared by an ADMO once the review IAW [paragraph 2.f.](#) is concluded.
 - h. **AGE Requiring Two or More Hyperbaric Treatments.** Unfit for flying for 10 days; unfit for diving until case review IAW [paragraph 2.f.](#) is concluded.
3. All determinations of medical fitness to dive must be recorded in the member's medical records. If necessary, the diver's personal log (CF 849) should also be annotated on the appropriate medical or dental exam page.

226. EMERGENCIES REQUIRING RECOMPRESSION

1. There are three general classes of diving medical emergency requiring treatment by recompression:
 - a. Arterial Gas Embolism (AGE),
 - b. Decompression Sickness (DCS), and
 - c. Omitted Decompression (“Omitted-D”).
2. Arterial Gas Embolism (AGE) is the most dangerous of the three and must be treated as an extreme emergency. It can occur during a brief, shallow dive, even a dive made in a swimming pool with breathing equipment. It develops rapidly and must be treated immediately.
3. Decompression sickness can be just as serious, but may develop quite gradually – up to 24 hours after the completion of a seemingly routine and uneventful dive. However, statistics indicate that most cases will occur within 6 hours of surfacing.
4. Omitted decompression results from failing to observe the appropriate decompression schedule, possibly as a result of serious injury to the diver in the water or an emergency at the dive station. In some cases, using one of the CAF Air Diving Tables may prevent decompression sickness. Otherwise, a therapeutic treatment table must be followed (refer to B-GG-380-000/FP-005, CAF Diving Manual, Vol. 5).

227. OMITTED DECOMPRESSION AND ARTERIAL GAS EMBOLISM, GENERAL

1. This Article deals with the two diving emergencies usually requiring the fastest reaction from the diving team: omitted decompression and arterial gas embolism.
 - a. **Omitted Decompression.** Omitted decompression (“Omitted-D”) may range from minor to major decompression deficits. For the purposes of the CAF Air Diving Tables “omitted decompression” is defined as “the time omitted from in-water decompression as calculated from the appropriate CAF Air Diving Table”.
 - b. **Pulmonary Overinflation Syndrome (POS).** POS is a general term used to describe the result of the expansion of gas which has been taken into the lungs while breathing under pressure and held in the lungs during a reduction in pressure, normally during ascent. The gas might have been retained in the lungs by choice (voluntary breath holding) or by accident (blocked air passages). The diver, reacting with panic to a difficult situation, may breath-hold without thought. This is a panic-induced involuntary reaction. Gas can also be trapped in a portion of a lung as a result of damage from previous disease or accident, active infection (e.g. pneumonia, bronchitis) or asthma.
2. When the lungs are overinflated and the alveoli rupture, gas can go to four locations:
 - a. **Arterial Gas Embolism (AGE).** Gas enters the capillaries surrounding the alveoli, travels back to the heart in the pulmonary veins, and is carried by the blood throughout the body.
 - b. **Pneumothorax.** Gas goes to the potential space between the lung and the chest wall causing collapse of the lung. This is rare in healthy individuals since the membrane covering is very tough and seldom ruptures.
 - c. **Mediastinal Emphysema.** Gas travels along the veins, arteries and bronchioles from the site of rupture in the periphery of the lung to surround the heart, great vessels and root of the lungs in the centre of the chest (mediastinum) and
 - d. **Subcutaneous Emphysema.** Gas travels up from the mediastinum to lie under the skin in the area above the clavicles at the base of the neck.

3. In AGE the gas bubbles in the blood may lodge in the arteries of the spinal cord or the brain, cutting off circulation causing paralysis, unconsciousness or death. If the brain is involved the term cerebral gas embolism may be used.

4. Pneumothorax, mediastinal and subcutaneous emphysema are generally not as life threatening as arterial gas embolism but must still be dealt with swiftly. Recompression is not indicated for pneumothorax, mediastinal/subcutaneous emphysema and treatment should be at the discretion of an Advanced Diving Medical Officer.

5. If gas in the lungs is not expelled, an ascent of only 1 metre can cause rupture of the alveoli. This is a more significant concern near the surface where expansion of the gas is greatest. Symptoms of AGE will normally be evident within minutes of surfacing. Speedy diagnosis treatment and recompression are essential if permanent injury or death is to be avoided.

228. OMITTED DECOMPRESSION

1. Omitted-D may range from a minor to a major decompression deficit.

2. Certain emergencies may interrupt or prevent planned decompression. Blow-up, an exhausted air supply or bodily injury constitute such emergencies. If the diver shows any symptoms of decompression sickness or gas embolism, immediate treatment using the appropriate oxygen treatment table is essential. Even if the diver shows no symptoms or ill effects (i.e. is asymptomatic), omitted decompression must be treated by recompression to reduce the risk of DCS.

3. The preferred action is to transport the diver to a recompression chamber (RCC) for treatment. The diver should receive 100% oxygen via a double-seal oral-nasal mask while enroute to the RCC.

4. When an RCC is immediately available, omitted decompression should be managed IAW B-GG-380-000/FP-003, B-GG-380-000/FP-004 and B-GG-380-000/FP-005 (Vols. 3, 4 and 5, CAF Diving Manual).

5. When transit to an RCC is not feasible, and the diver is asymptomatic (refer to [Articles 235](#) to [238](#)), the Diving Supervisor may:

- a. Return the diver to a depth one stop deeper than where the omission occurred, repeat this stop and continue decompression IAW the original schedule, or
- b. If the omission occurred at the first stop, return the diver to a depth one stop deeper and remain there for the time scheduled for the first stop. Continue decompression IAW the original schedule.

6. While conducting a Sur-D, if for any reason the Sur-D procedure cannot be completed, the diver must be treated using emergency procedures IAW B-GG-380-000/FP-003 and B-GG-380-000/FP-004, Vols 3 and 5, CAF Diving Manuals).

7. If a diver omits decompression and violated the seven-minute Surface Interval, use Treatment Table protocol found in B-GG-380-000/FP-003 and B-GG-380-000/FP-005 (Vols. 3 and 5, CAF Diving Manual).

NOTE

All CAF Treatment Tables are found in B-GG-380-000/FP-005.

229. ARTERIAL GAS EMBOLISM (AGE)

1. Arterial gas embolism must be diagnosed quickly and correctly. The supply of blood to the brain is almost always involved and unless promptly and properly treated (by recompression), gas embolism is likely to result in permanent disability or death. The circulation time from the heart to the brain is only a few seconds and neurological symptoms such as unconsciousness will normally occur within a few minutes of reaching the surface.

2. Any central nervous system (CNS) symptom that develops more than ten minutes after surfacing is rarely the result of gas embolism. CNS symptoms are described in [Article 237](#).
3. Any diver who may have obtained a breath from any source at depth and who loses consciousness or exhibits any neurological symptom within ten minutes after reaching the surface must be assumed to be suffering from arterial gas embolism. Recompression treatment must be started *immediately*.
4. Other factors to consider in diagnosing arterial gas embolism are:
 - a. The onset is usually sudden and dramatic, often occurring within seconds after arrival on the surface or even before reaching the surface. The signs and symptoms may include:
 - (1) Bloody, frothy sputum, dizziness, paralysis, weakness, respiratory failure, disturbance of vision or convulsions. The diver may have noticed chest pain or a sensation like a blow to the chest during ascent.
 - (2) It is common for the first symptom to be convulsion or loss of consciousness.
 - b. A diver suffering from decompression sickness may also experience some of these symptoms but the time of onset is normally later.
 - c. If the dive has been to a depth of less than 9 msw, decompression sickness is unlikely and arterial gas embolism must be assumed.
 - d. If the only symptom is pain, AGE is unlikely and decompression sickness or one of the other conditions resulting from a burst lung should be assumed.
 - e. The dive profile will usually provide clues to the correct diagnosis (i.e. uncontrolled or rapid ascent).
5. Some symptoms may be masked by environmental factors or by other, less significant symptoms. A diver who is chilled may not be concerned with numbness in an arm. Pain from any source may divert attention from other symptoms. The natural anxiety that would accompany the failure of the air supply, for example, might mask anxiety or a state of confusion that is actually being caused by AGE affecting the brain. A diver who is coughing up blood or bloody froth may be showing signs of ruptured lung tissue or may have merely bitten his or her tongue.
6. Ambiguities of this sort will usually be quickly resolved by the appearance of more severe symptoms. However, once the diver is in the hyperbaric chamber it may be difficult to evaluate symptoms.
7. Pneumothorax, mediastinal and/or subcutaneous emphysema may accompany AGE. Therefore, a very careful neurological examination must always be performed and if there are any neurological signs or symptoms, immediate treatment for AGE must be initiated.
8. The treatment for arterial gas embolism is usually longer and more aggressive than treatment of other diving injuries because the risk of permanent brain damage is much greater.
9. IF THERE IS ANY DOUBT REGARDING THE CORRECT DIAGNOSIS, IT MUST BE RESOLVED IN FAVOUR OF THE DIVER. ASSUME ARTERIAL GAS EMBOLISM AND TREAT ACCORDINGLY.

230. PNEUMOTHORAX

1. Chest pain and the coughing up of blood or bloody froth frequently accompany pneumothorax. Shallow, rapid breathing, an increased pulse rate, cyanosis and/or subcutaneous emphysema may also be present. Pneumothorax may be detected by listening to both sides of the chest. Chamber venting and other noises will need to be suppressed to do this effectively. Breath sounds will be decreased or inaudible over the site where a significant pneumothorax exists.

231. MEDIASTINAL EMPHYSEMA

1. The symptoms of mediastinal emphysema may include discomfort or pain under the breastbone, shortness of breath and faintness. These latter two would be the result of the trapped gas pressing against the lungs, heart and large blood vessels, thereby interfering with breathing and/or circulation. This might also be evidenced by blueness (cyanosis) of the skin, lips or fingernails.

232. SUBCUTANEOUS EMPHYSEMA

1. The victim – except in an extreme case – may not notice subcutaneous emphysema, although the diver might experience a feeling of fullness around the neck and have difficulty swallowing. The sound of the diver's voice may change and an observer may note a marked swelling or inflation of the diver's neck. Movement of the skin near the collarbone may produce a crackling or crunching sound (crepitation).

233. DECOMPRESSION SICKNESS

1. Decompression sickness (DCS) is caused by inadequate decompression. Occasionally, DCS occurs even when normal decompression procedures are followed. Certain factors increase the likelihood of DCS, even when following standard procedures. These predisposing factors must be taken into account by increasing decompression time when necessary or by avoiding or minimising the predisposing factor.

234. PREDISPOSING FACTORS FOR DECOMPRESSION SICKNESS

1. The likelihood of DCS increases when one or more of the following factors are involved:
 - a. Injury (previously injured sites may develop DCS more easily),
 - b. Obesity,
 - c. Hangover (after alcohol consumption),
 - d. Age (risk increases with age),
 - e. Strenuous physical exercise (before, during or after diving),
 - f. Dehydration from any cause (e.g. hangover),
 - g. Poor physical fitness,
 - h. Cold (especially during decompression),
 - i. Mental stress (unfamiliarity with diving, fear or anxiety),
 - j. Fatigue, and
 - k. Infection.
2. Whenever possible, the complete history of the dive and any predisposing factors should be taken into account when diagnosing DCS.

235. DIAGNOSIS OF DECOMPRESSION SICKNESS

1. Decompression sickness usually causes symptoms within a short time following the dive or pressure exposure. If the required decompression has been severely shortened or completely omitted, the diver could suffer decompression sickness before reaching the surface. In general, the time of occurrence for the onset of the first symptom after surfacing is as follows:

- a. 70% of first symptoms occur within 1 hour after surfacing,
 - b. 90% of first symptoms occur within 6 hours after surfacing and
 - c. 99% of first symptoms occur within 24 hours after surfacing.
2. When the first symptom occurs more than 24 hours following a dive, other causes should be suspected before decompression sickness, acknowledging that divers may experience a symptom and not report it right away.
3. Factors to be considered in evaluating symptoms include the depth and duration of the dive, the decompression table used, the stress of the dive (e.g. cold, hard work) and the probability of other conditions such as gas embolism. The best-qualified person available should make a presumptive diagnosis. This must not be delayed while awaiting the arrival of a better-qualified person.
4. A wide range of symptoms may signal the onset of decompression sickness and some will be so obvious that the diagnosis will not be in doubt. Subtle symptoms may not be detected if a complete examination of the patient is not performed.
5. Symptoms of decompression sickness among professional divers have been found to occur with the following frequency:
- a. **Pain Only.** 80%. Pain is a symptom in over 90% of all cases.
 - b. **Neurologic.** 15%.
 - c. **Vestibular.** Less than 1%.
 - d. **Pulmonary (Chokes).** Less than 1%.
 - e. **Other.** 3% to 5%.
 - f. **Fatigue.** A common symptom in all cases of DCS.
6. Eighty percent of recreational divers with decompression sickness who are treated at a hyperbaric chamber have neurologic symptoms. The reason that pain as the only symptom is less commonly reported among recreational divers is probably because many sport divers with pain do not have easy access to hyperbaric treatment and tend not to report it. CAF Divers are well supported by hyperbaric facilities and are to report post-dive pain without delay.
7. IF IN DOUBT, SEEK DIVING MEDICAL ASSISTANCE. Refer to [page i/ii, Diving Emergency Assistance/Medical Consultation](#).

236. DECOMPRESSION SICKNESS – MILD (DCS TYPE I)

1. Pain is the most common symptom of decompression sickness in professional divers. The pain is usually slight when first noticed, but may grow progressively worse until it becomes unbearable. It may seem to come from deep in a bone and will often be near a joint. It is easy to misinterpret pain as being due to a sprain or a bruise. Pain should not be treated with drugs in an effort to make the patient more comfortable because pain is often the only way to measure the effectiveness of the treatment.
2. Abdominal pain may signal involvement of the spinal cord and therefore should be regarded as a potentially serious symptom. The diver should be carefully examined for other signs or symptoms of DCS and treated accordingly. A diver with abdominal pain after a dive should at the very least be carefully observed for the development of decompression sickness for several hours after surfacing.

3. “Niggles” or short duration aches and pains may be signs of decompression stress, but if there is any doubt as to the origin of the pain, then assume that the diver is suffering from decompression sickness and treat accordingly.
4. Lymphatic DCS results from blockage of the lymphatic ducts by bubbles. The subsequent buildup of fluid in the tissues causes localised swelling and edema. Recompression treatment should be initiated.
5. “Skin bends” refers to decompression sickness caused by blockage of the circulation in the skin by bubbles. It presents as a swollen, red or mottled tender area of skin. A DMO may prescribe recompression treatment.
6. Other skin symptoms that are frequently observed after a dive include a painless rash, itching and pricking. These symptoms are usually due to gas dissolving directly in the skin and occur after dives in which the skin is exposed to gas (chamber, drysuit) and not after wet suit or hot water suit dives. This is not decompression sickness and does not require treatment.
7. Symptoms of localised pain, edema and/or an area of tender, red or mottled, raised skin are to be diagnosed as mild, Type I DCS and should be treated with the appropriate oxygen treatment table.
8. IF IN DOUBT, SEEK DIVING MEDICAL ASSISTANCE. Refer to [page i/ii, Diving Emergency Assistance/Medical Consultation](#).

237. DECOMPRESSION SICKNESS – SERIOUS (DCS TYPE II)

1. Central nervous system (CNS) and/or spinal cord involvement is a serious problem requiring prompt treatment. In severe cases (e.g. blow-up, unconscious diver or life-threatening symptom) immediate recompression is essential. A short delay is acceptable to allow surface examination by diving medical personnel, preferably an Advanced Diving Medical Officer.
2. The examination may be completed in the chamber at treatment pressure; however, at greater depths this will prove difficult owing to noise, heat and narcosis.
3. Since treatment for serious, Type II DCS is designed to treat the “worst case”, any less serious symptoms that may go unnoticed will be appropriately treated.
4. The symptoms of serious, Type II DCS, in order of frequency, include:
 - a. Numbness,
 - b. Dizziness or vertigo,
 - c. Nausea or vomiting,
 - d. Visual disturbances,
 - e. Paralysis,
 - f. Headache (severe),
 - g. Unconsciousness,
 - h. Urinary disturbances,
 - i. Shortness of breath (chokes),
 - j. Personality change,

- k. Agitation or restlessness,
- l. Fatigue (severe),
- m. Muscular twitching,
- n. Confusion,
- o. Lack of coordination, and
- p. Balance problems.

NOTE

Many of these symptoms are easily overlooked or passed off by the victim as being of no consequence. For this reason, watch for these symptoms during the immediate post-dive activities of the divers, who may only think that they have been working too hard. The foregoing types of symptoms are categorized as serious, Type II DCS.

5. IF IN DOUBT, SEEK DIVING MEDICAL ASSISTANCE. Refer to [page i/ii, Diving Emergency Assistance/Medical Consultation](#).

238. RAPID NEUROLOGICAL EXAMINATIONS

1. All divers responsible for supervising should be able to perform a rapid assessment of neurologically-related symptoms. The diagnosis of DCS may depend upon the detection of subtle or deceptive signs (see [Figure 2-2](#)).
2. A detailed examination performed by qualified personnel may be conducted IAW Diving Incident/Accident Report Forms 5(1) and 5(2) contained in Chapter 1, [Annex A1](#).

RAPID NEUROLOGICAL EXAMINATION		
Patient's Name _____		Place _____
Date _____		Time _____
Normal	Abnormal	Head and neck
_____	_____	Orientation (time, person, place)
_____	_____	Visual acuity (count fingers, ask about double vision)
_____	_____	Visual fields (bring fingers from behind patient's head)
_____	_____	Pupils equal and reactive to light
_____	_____	Eye movement ("H" pattern; nystagmus)
_____	_____	Sensation of forehead, cheeks, lower jaw
_____	_____	Clench teeth (check jaw muscles)
_____	_____	Furrow brow
_____	_____	Shut eyes tight (check muscles above/below eyes)
_____	_____	Smile or grimace
_____	_____	Check hearing/noises
_____	_____	Swallow
_____	_____	Shrug shoulders (apply force to shoulders, check resistance)
_____	_____	Protrude tongue (check for deviation to one side)
SENSATION		
_____	_____	Ask about any unusual sensation
_____	_____	Check sensation of arms, back, trunk, legs
_____	_____	Ask if the sensation is the same on both sides
MOTOR FUNCTION		
_____	_____	Finger squeezes bilaterally
_____	_____	Thumbs up, resisting pushing arms apart and thumbs down, resisting pushing arms together.
_____	_____	Check flexion and extension of hip, knee and ankle
_____	_____	Plantar reflex (toes down = normal)
NOTE		
Add explanatory note for all abnormalities.		

Figure 2-2 Rapid Neurological Examination

RECOMPRESSION TREATMENT

239. GENERAL PROCEDURE

1. When a diver has received inadequate decompression or has an air embolism, the first treatment procedure is to return the diver to a pressurised environment where the expanded gases will be recompressed. This should reduce any localised pain caused by gas bubbles, may restore normal blood flow and will frequently relieve the patient of many if not all of the subjective symptoms. After recompression treatment is underway additional treatment may be administered.
2. In all cases involving recompression treatment, a qualified Clearance Diving Supervisor is to take charge of the hyperbaric chamber and be responsible for the chamber operation. In the absence of a Medical Officer qualified and current in diving medicine, the Clearance Diving Supervisor shall choose the treatment table to be used.
3. When contacted, an Advanced Diving Medical Officer (ADMO) will assume complete control and responsibility for the well being of the patient. The ADMO will diagnose diving ailments and have control of all aspects of treatment of the patient. Only an ADMO may order a deviation from the standard treatment tables published in the CAF Diving Manual. The ADMO must be prepared to justify such deviation to a possible BOI. Any deviation must be clearly communicated to the Diving Officer/Chamber Supervisor by the ADMO. The deviation and the reason for the deviation are to be recorded on the Treatment Dive Record.
4. Certain facets of recompression treatment have been previously mentioned but they are so important that they cannot be overstressed:
 - a. Treat promptly and adequately. Do NOT delay treatment by waiting for the arrival of medical personnel. The longer the time between the onset of symptoms and the initiation of treatment, the less effective the treatment.
 - b. Do NOT ignore seemingly minor symptoms. They can quickly become major.
 - c. Follow the selected treatment table accurately and completely. If a symptom or group of symptoms seems to be relieved, do not assume that the treatment is finished. Follow the tables to completion.
 - d. Keep the diver in the immediate vicinity of the chamber or the diving station for at least 6 hours following recompression. Keep the diver within 1 hour's travel time to the chamber for a period of 24 hours.
 - e. Careful attention should be paid to the dive partner; the dive partner should accompany the Diving Supervisor and the patient.
5. Following the completion of the treatment table and after a surface interval sufficient to allow complete medical evaluation, hyperbaric oxygenation treatment may be continued when recommended by the ADMO.
6. See [Figure 2-3](#) for mandatory restrictions on diving or flying after recompression treatment.
7. Advice on diving medical problems may be obtained from the senior Diving Medical Officer at DRDC – Toronto. Emergency consultation is available on a 24-hour basis. Refer to [page i/ii, Diving Emergency Assistance/Medical Consultation](#).

Diver treated for	Restrictions following Treatment
DCS Type I (pain-only)	a. Unfit for diving for 7 days. b. Unfit for flying for 3 days.
DCS Type II or Gas Embolism	a. Unfit for diving for 30 days. b. Unfit for flying for 7 days. c. If there were residual symptoms or if repeated treatments were required, the patient is unfit for flying for 10 days and unfit for diving until the case has been reviewed by Central Medical Board (Diving) at DRDC – Toronto and a decision made on the patient’s fitness to dive.
Asymptomatic Omitted Decompression	a. A diver who has been treated for asymptomatic omitted decompression will have been treated on either a TT5 or TT6. Owing to the amount of oxygen breathed and the elimination of inert gasses, no restrictions for flying or diving are required.

Figure 2-3 Restrictions on Diving or Flying After Recompression Treatment

240. HYPERBARIC CHAMBER

1. If there is no hyperbaric chamber on site, the Diving Supervisor has two alternatives:
 - a. If recompression of the patient is not immediately necessary, transport the patient to the nearest hyperbaric chamber for treatment.
 - b. If a transportable two-man chamber is available and the situation permits, the diver may be transported under pressure to the nearest full-size chamber.
 - (1) CAF Diving Manual, Volume 5 covers the use of transportable chambers.
2. Also refer to [Article 228](#), *Omitted Decompression*, for instructions for in-water recompression for omitted decompression when transport to an RCC is not feasible.
3. The location of the nearest hyperbaric chamber must be included in the data collected during the planning phase of the dive. Refer to [Articles 502](#), [503](#) and see [Figure 5-1](#), *CAF Diving Emergency Planning and Task Definition Grid*.

241. TRANSPORTING THE PATIENT

1. Not all patients will require immediate recompression; a certain delay may be acceptable while the patient is being transported to a hyperbaric chamber.

WARNING

While preparing a patient for recompression (when a delay is necessary) and while moving the patient to a chamber, the patient should be kept lying down in a horizontal position, on either side, and given oxygen if available.

WARNING

Additionally, the patient should be kept warm and his/her condition constantly monitored for signs of a blocked airway, fainting, cardiac arrest, cessation of breathing or sudden massive internal bleeding.

WARNING

Always keep in mind that the most obvious symptoms may not actually be related to the most serious problem and that a number of conditions may well exist at the same time. For example, the victim may be suffering from both decompression sickness and severe internal injuries.

2. If the patient must be transported, the initial arrangement will have been made well in advance of the actual diving operation. These arrangements, which would include an “alert” notification to the hyperbaric chamber staff and a determination of the most effective means of transportation, are set out in the emergency assistance checklist for instant reference (see [Figure 5-1](#), *CAF Diving Emergency Planning and Task Definition Grid*).
3. The patient should be accompanied by the Diving Supervisor who was in charge of the diving operation, the diving partner and if available, an ADMO. If it is not possible for the Diving Supervisor to attend, another diver who knows the full details of the case must accompany the patient. In all cases the Diving Incident/Accident Report Forms shall be completed as far as is practicable and shall accompany the patient in transit.
4. If a civilian-manned chamber is to be used, the Diving Supervisor must accompany the patient and if appropriately qualified be responsible for treatment.
5. If the patient is moved by air, the helicopter or other aircraft should be flown as low as possible consistent with aircraft safety. Otherwise, a further reduction in external pressure may result in worsening symptoms or additional complications. While in transit, oxygen (if available) should be administered to the patient.
6. If communications can be established while in transit, obtain consultation with the ADMO at the hyperbaric chamber.
7. Therapeutic recompression in the water should never be attempted except in the case of omitted decompression when an RCC is not immediately available (refer to [Article 228](#), Omitted Decompression).

242. TREATMENT TABLES

1. Standard, modified and alternate treatment tables and procedures are set out in B-GG-380-000/FP-005, Canadian Armed Forces Diving Manual, Vol. 5, Hyperbaric Chamber – Operation and Treatment Procedures. Extensive research and field experience has shown the therapeutic value of oxygen administered during recompression treatment.

243. GENERAL RESTRICTIONS AFTER RECOMPRESSION TREATMENT

1. After surfacing the patient should be kept under observation for 1 hour and then re-examined for residual symptoms.

2. During the 24-hour period following any treatment the patient must remain within 1 hour's travel time of the chamber.
3. Restrictions beyond 24 hours are laid down in Volume 5.
4. See also [Figure 2-3](#), *Restrictions on Diving or Flying after Recompression Treatment*.

244. HYPERBARIC CHAMBERS – OTHER USES

1. In addition to their use for the treatment of decompression sickness and surface decompression, hyperbaric chambers are also used for administering pressure tolerance tests to divers and prospective divers. In other than diving applications, hyperbaric chambers are used for medical treatment (both routine and emergency) of various disorders, notably gas gangrene. Chambers may also be located in research laboratories and in military and commercial aviation schools and operating facilities. Chambers used to create less than atmospheric pressures are called hypobaric chambers.
2. Diving team supervisors must always know the location, availability and type of the nearest chamber before commencing diving operations.
3. When hyperbaric chambers are used for treatment of ailments other than those related to diving, the attending medical officer or physician is solely responsible for the choice and control of the treatment. The Diving Supervisor is responsible for the safe operation of the chamber.

CHAPTER 3
AIR DECOMPRESSION PROCEDURES AND TABLES
GENERAL

301. INTRODUCTION

1. When air is breathed at depth, inert breathing gas (nitrogen) diffuses into the various tissues of the body. Nitrogen diffusion continues at different rates for the various tissues as long as the partial pressure of the inspired nitrogen (ppN₂) is greater than the partial pressure of the gas absorbed in the tissues.
2. The amount of absorbed nitrogen varies with:
 - a. Depth (ppN₂ increases with depth), and
 - b. Duration of exposure (i.e. bottom time [includes descent time at proper rate]).
3. When the diver ascends (decompression time (includes ascent time and stop time)), the process is reversed as the nitrogen partial pressure in the tissues exceeds that in the circulatory and respiratory systems. This pressure gradient from the tissues of the blood and lungs must be carefully controlled to prevent a too rapid diffusion of nitrogen. If the pressure gradient is uncontrolled, bubbles of nitrogen gas form in the tissues and blood that can result in decompression sickness.
4. To prevent decompression sickness, air decompression tables have been developed for CAF divers. These tables take into consideration the amount of nitrogen absorbed by the body at various depths for given periods of time. The tables also take into account the allowable pressure gradients that can exist without excessive bubble formation and the different gas elimination rates associated with various body tissues.

302. BACKGROUND

1. The CAF Air Diving Tables and air decompression procedures were derived from the DCIEM 1983 Decompression Model (DCIEM, or the Defence and Civil Institute of Environmental Medicine, is now known as DRDC (Defence Research and Development Canada)). This model was the result of over 20 years of decompression research that began with the pioneering studies by Kidd and Stubbs in 1962. These tables provide a conservative approach to decompression procedures.
2. Selected profiles were tested extensively using the Doppler ultrasonic bubble detector as an aid to assessing the severity of the decompression stress produced by these tables. These tables were tested in a hyperbaric chamber with wet/working divers in cold water between 5 – 10°C as well as with dry/resting divers. Doppler ultrasonic bubble detection procedures used to evaluate the model showed that the basic conservatism of the model was indeed justified. No realistic decompression procedures can totally eliminate the occurrence of decompression sickness.
3. The CAF Air Diving Tables set out decompression schedules for standard air decompression, for in-water oxygen decompression, for surface decompression with oxygen, for repetitive diving, and for diving when at altitude.
4. The Standard Air Decompression Table (CAF Air Diving Table 1 (excerpt)), the Short Standard Air Decompression Table (CAF Air Diving Table 1S), the Repetitive Diving Table (CAF Air Diving Table 4: comprising CAF Air Diving Tables 4A, Repetitive Factors/Surface Intervals Table and CAF Air Diving Table 4B, No-Decompression Repetitive Diving Table) and the Depth Corrections for Diving at Altitude Table (CAF Air Diving Table 5) as included herein are approved for use with Compressed Air Breathing Apparatus (CABA).
5. [Figure 3-1](#) shows the Normal Air Diving Range and the Exceptional Exposure Range for these tables.

6. All depths are measured in metres of seawater (msw) refer to Chapter 3, [Annex A3](#), *Canadian Armed Forces Air Diving Tables (METRES)*.

303. AIR DECOMPRESSION TABLES APPROVED FOR USE WITH COMPRESSED AIR BREATHING APPARATUS (CABA)

1. Canadian Armed Forces Air Diving Tables (METRES)

a. Refer to Chapter 3, [Annex A3](#):

- (1) CAF Air Diving Table **1** (METRES) Standard Air Decompression Table (*Excerpt. Covers only depths to 51 msw [45 msw + 13%]*).
- (2) CAF Air Diving Table **1S** (METRES) Short Standard Air Decompression Table.
- (3) CAF Air Diving Table **4** (METRES) Repetitive Diving:
 - (a) CAF Air Diving Table **4A** (METRES) Repetitive Factors/Surface Intervals Table.
 - (b) CAF Air Diving Table **4B** (METRES) No-Decompression Repetitive Diving Table.
- (4) CAF Air Diving Table **5** (METRES) Depth Corrections for Diving at Altitude Table.

2. These tables cover only bottom times to the limit of the Normal Air Diving Range as shown in [Figure 3-1](#).

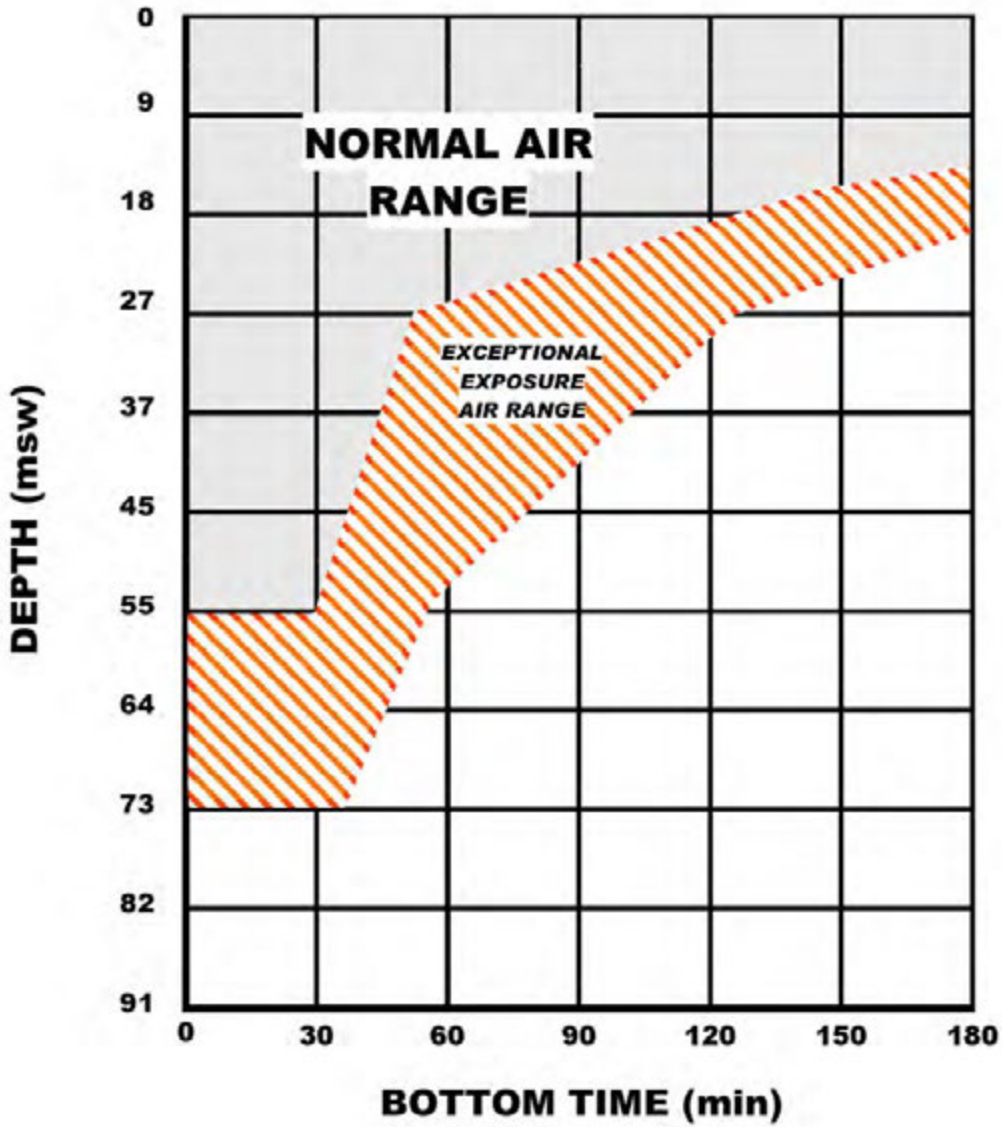

Y583FP0033-00

Figure 3-1 Air Diving Limits

304. DEFINITION OF TERMS

1. **Allowable No-D Limit** Maximum bottom time allowing a direct ascent to the surface without requiring decompression stops.
2. **Ascent rate** Specified rate of travel that the diver must maintain up to and between decompression stops: 18 ± 3 mpm.
3. **Bottom time (BT)** Total elapsed time in minutes, beginning when the diver leaves the surface to when (rounded to the next whole minute) the diver leaves bottom.
4. **Decompression schedule** Specified decompression procedure for a given combination of depth/bottom time as listed in a decompression table, i.e. Depth (msw)/BT (min).
5. **Decompression stop** Specified length of time which a diver must spend at a specified depth to allow for the elimination of sufficient inert gas from the body to allow safe ascent to the next decompression stop or the surface.
6. **Depth** Maximum depth attained, measured in msw.
7. **Descent rate** Rate of descent to the bottom: 18 mpm or slower.
8. **Effective bottom time (EBT)** Calculated BT for decompression purposes taking into consideration residual nitrogen from a previous dive (repetitive diving).
9. **Effective depth (ED)** Depth of an equivalent dive at sea level (altitude diving).
10. **No-decompression limit** Maximum bottom time allowing a direct ascent to the surface without requiring decompression stops.
11. **Omitted decompression** Time omitted from in-water decompression calculated from the appropriate CAF Decompression Table.
12. **Repetitive dive** Any dive that has a RF greater than 1.0.
13. **Repetitive factor (RF)** The Repetitive Factor (RF) is two-digit number (1.0 – 2.0) relating directly to the RG and to the length of the surface interval after a dive and is only required when repetitive diving is conducted.
14. **Repetitive group (RG)** A letter (A – O) relating to the amount of residual nitrogen in the diver upon surfacing after a dive.
15. **Residual nitrogen** Excess nitrogen still dissolved in a diver's tissues after the surface has been reached.
16. **Single dive** A dive measured from the time the diver leaves the surface to the time the diver reaches the surface. If the diver remains on the surface for less than 15 minutes ($SI < 15$) and then continues to dive, or repetitive factor is greater than 2 ($RF > 2$) the combined bottom times are considered a single dive.
17. **Surface interval (SI)** Time a diver has spent on the surface following a dive, beginning as soon as the diver surfaces and ending as soon as the diver starts the descent of the next dive.
18. **Total time of dive (TT)** Time measured from the diver's leaving the surface to the diver's reaching the surface. Includes bottom time, ascent time, decompression stops and any delay(s) on ascent.

305. DIVE RECORDING

1. Every CAF dive must be recorded. Worksheets for no-decompression dives ([Figure 1-14, Diving Supervisor's No-D Log / Worksheet](#)) or planned decompression dives ([Figure 3-4, Dive Record Chart \(METRES\)](#)) must be completed and retained on file for five (5) years by the Unit conducting the dive. These worksheets are a convenient means of collecting the dive data that must also be entered into the CF 849 and CAFDITS CF 850.

306. IN-WATER DECOMPRESSION

1. Only personnel qualified IAW [Figure 1-1](#) may conduct planned decompression diving. Dives in CABA should normally be planned to terminate before there is a need to decompress. If decompression is required, preparations must be made before the dive commences. This includes:

- a. Briefing of personnel,
- b. Preparation of equipment,
- c. Checking decompression tables, and
- d. Consideration of emergency procedures.

2. Only a worked-up and confident diver supported by an experienced diving team should conduct in-water decompression. Refer to [Article 515, Lazy Shot Diving Procedures](#).

3. The availability of a recompression chamber must be considered when planning dives involving in-water decompression. Refer to [Articles 502, Dive Planning – General](#) and [503, Dive Task Planning and Emergency Assistance](#).

4. In rough seas, when the Supervisor determines that the diver's stop depth cannot be adequately controlled, in-water decompression dives shall not be attempted.

307. FAILURE TO DECOMPRESS IN-WATER

1. If for any reason a diver is unable to carry out in-water decompression procedures the diver is to be treated for omitted decompression IAW [Article 228](#).

INSTRUCTIONS FOR THE USE OF CAF AIR DECOMPRESSION TABLES

308. STANDARD AIR DECOMPRESSION TABLE (CAF AIR DIVING TABLE 1) (EXCERPT)

1. The Standard Air Decompression Table is set out in rows by depth in metres and in columns by bottom time (BT), with stop times, total decompression time and Repetitive Group (RG) designator set out for each depth and bottom time.

2. All depths are measured in metres of seawater (msw). Refer to CAF Air Diving Table 1 (METRES), *Standard Air Decompression Table* (excerpt: covers only depths to 51 msw (45 msw + 13%)), Chapter 3, [Annex A3](#).

3. **No-Decompression Limits.** No-decompression limits in CAF Air Diving Tables 1 and 1S are for first dives only.

4. **Descent Rate.** Descend at 18 mpm or slower.

5. **Ascent Rate, Stops, Stop Times and Travel Time.** Ascend at 18 ±3 mpm to the indicated stops and remain at each stop for the required stop time. Stop time for each stop includes travel time to that stop at 18 ±3 mpm.

6. **Variations in Rate of Ascent.**

a. **Ascent Rate Too Slow ...<15 mpm:** When a delay in travelling has occurred, the appropriate correction must be applied as follows:

- (1) Delay starts deeper than half the maximum depth of the dive:
 - (a) Add delay to bottom time.
 - (b) Decompress IAW new bottom time.
- (2) Delay starts shallower than half the maximum depth of the dive:
 - (a) Add delay to stop time of next stop. If no stop is scheduled, then stop at 3 msw for the time of the delay.

NOTE

The revised stop time includes the ascent time from the depth where the delay occurred to the next stop.

Examples: ie: dive profile chart.

b. **Ascent Rate Too Fast:** > 21 mpm

- (1) **To First Stop.** No correction is required (time at stop includes travel time to the stop).
- (2) **No Stops Required.** Observe diver for at least one (1) hour after surfacing.

7. **Omitted Decompression.** Failure to comply with planned decompression procedures may result in omitted decompression. This is a significant hazard to the diver and must be dealt with immediately. Refer to [Article 228](#), Omitted Decompression.

8. **Using CAF Air Diving Table 1**

a. **EXAMPLE 1**

NOTE

Determine the decompression schedule required for a dive to 31 msw with a bottom time of 22 minutes using CAF Air Diving Table 1.

- (1) Enter CAF Air Diving Table 1 at the left-hand depth column at the depth equal to or next greater than 31 msw.
Select "33"
- (2) Using the 33 msw schedule proceed to the bottom time column and find the bottom time equal to or next greater than 22 minutes.
Select "25"
- (3) Proceed horizontally across the table on the 33 msw / 25-min row to find the decompression stop depths, decompression stop times and the Repetitive Group (RG) designator of this dive.

- (4) Decompression schedule for a dive to 31 msw, BT of 22 minutes from CAF Air Diving Table 1:

33 msw / 25 min
RG = G

6 msw stop for **6-minutes** Includes travel time from 31 msw. Travel time to 6 msw is 1.4 minutes. Actual 6 msw stop time is therefore 4.6 minutes (6 - 1.4 = 4.6).

3 msw stop for **10-minutes** Includes ascent time from 6 msw.

(Art. 308, EXAMPLE 1)

CANADIAN ARMED FORCES AIR DIVING TABLE 1 STANDARD AIR DECOMPRESSION TABLE											
Depth (msw)	Bottom Time (min)	Stop Time (min) at Depth (msw)							Decom. Time (min)	RG	
		24	21	18	15	12	9	6			3
33	25	-	-	-	-	-	-	6	10	16	G

- (5) A dive profile and chart for this example are set out in [Figures 3-2](#) and [3-3](#), respectively.

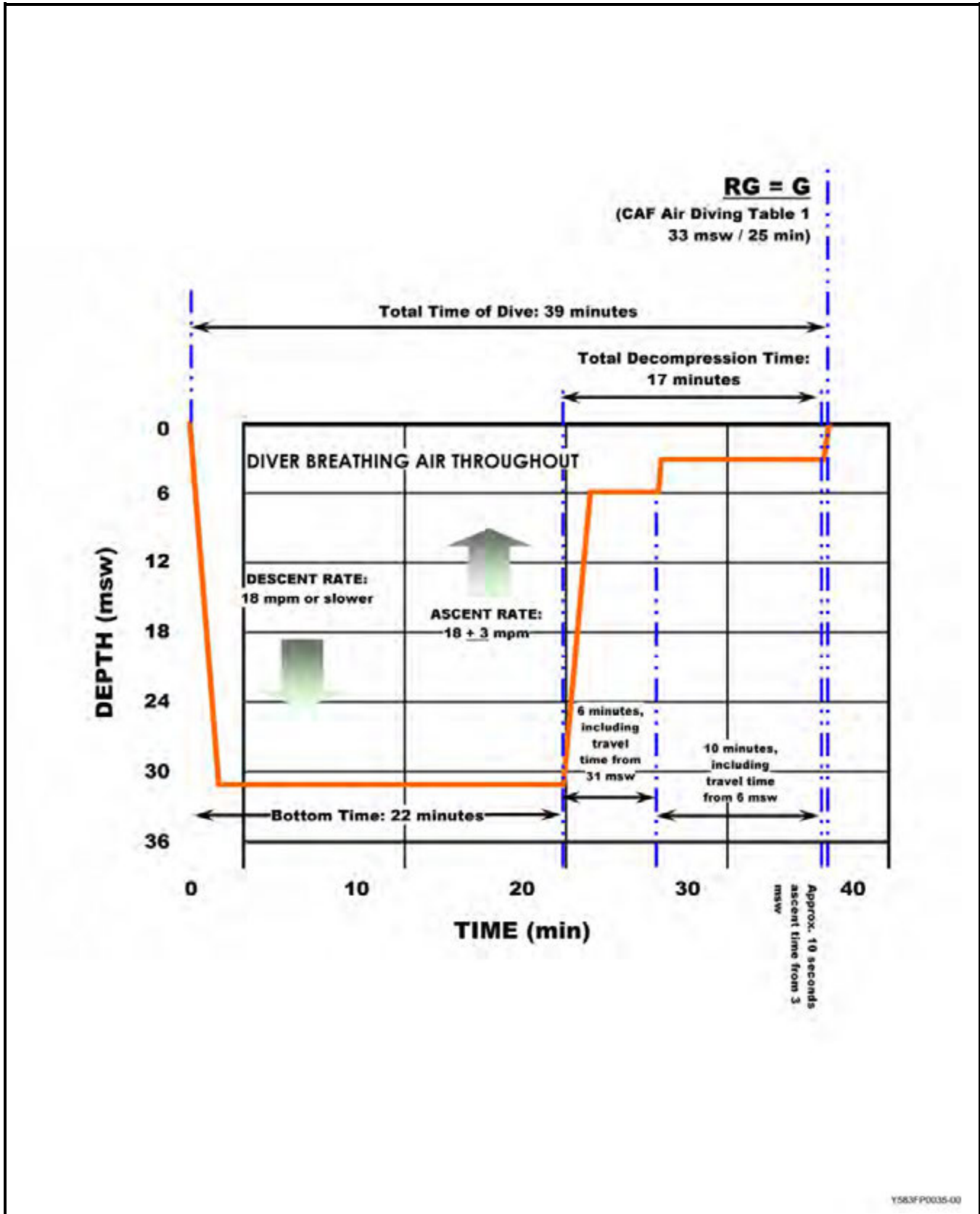

Figure 3-2 Standard Air Decompression Dive Profile, 31 msw/22 min (ref. [Article 308, paragraph 8, Example 1](#))

DIVER LUNN, M.	Rank P2	Tender FONTAINE, G.	Rank LS	DATE 21 Nov 10			
DIVER WILLIAMSON, G.	Rank P2	Tender DOCHERTY, J	Rank LS	Table Used CF 1			
SUPERVISOR WALSH, P.	Rank P1	Schedule Used 33 / 25	O ₂ % AIR	Depth (m) 31	Bottom time :22		
Left Surface (Clock Time) 1430	Left Bottom (Clock) 1452	Max Time to 1 st Stop /	Reached Surface (Clock Time) 1509				
Total Decompression Time :17	Total Time of Dive :39	Repet Group (RG) G	CHARTMAN (Print) NOSEWORTHY, D.		Rank LS		
REMARKS	STOPS (metres)	STAND AIR TABLE	Decompression Time		EMERG AIR	Event Time	
			Water	Chamber		Water	Chamber
	3		10			L :38	
						S	
	6		6			L :28	
						S	
	9					L	
						S	
	12					L	
						S	
	15					L	
						S	
	18					L	
						S	
	21					L	
						S	
	24					L	
						S	
	27					L	
						S	
REACHED BOTTOM :02	31 30					L :22	
						S	
	33					L	
						S	
	36					L	
						S	
	39					L	
						S	
	42					L	
						S	
	45					L	
						S	
	48					L	
						S	
	51					L	
						S	
Purpose of Dive		Supervisor (Signature)		Chartman (Signature)			
Location of Dive		Name / Rank of Standby Diver		Divers (Signatures)			

Y583FP0036-00

Figure 3-3 Dive Record Chart (Metres): Standard Air Decompression Dive, 31 msw/22 min (ref. [Article 308, paragraph 8, Example 1](#))

DIVER	Rank	Tender	Rank	DATE			
DIVER	Rank	Tender	Rank	Table Used			
SUPERVISOR	Rank	Schedule Used	O ₂ %	Depth (m)	Bottom time		
Left Surface (Clock Time)	Left Bottom (Clock)	Max Time to 1 st Stop	Reached Surface (Clock Time)				
Total Decompression Time	Total Time of Dive	Repet Group (RG)	CHARTMAN (Print)		Rank		
REMARKS	STOPS (metres)	STAND AIR TABLE	Decompression Time		EMERG AIR	Event Time	
			Water	Chamber		Water	Chamber
	3					L	
						S	
	6					L	
						S	
	9					L	
						S	
	12					L	
						S	
	15					L	
						S	
	18					L	
						S	
	21					L	
						S	
	24					L	
						S	
	27					L	
						S	
	30					L	
						S	
	33					L	
						S	
	36					L	
						S	
	39					L	
						S	
	42					L	
						S	
	45					L	
						S	
	48					L	
						S	
	51					L	
						S	
Purpose of Dive		Supervisor (Signature)		Chartman (Signature)			
Location of Dive		Name / Rank of Standby Diver		Divers (Signatures)			

Y583FP0037-00

Figure 3-4 Dive Record Chart (Metres)

309. SHORT STANDARD AIR DECOMPRESSION TABLE (CAF AIR DIVING TABLE 1S)

1. The Short Standard Air Decompression Table is essentially a simplified one-page version of CAF Air Diving Table 1 limited to 45 msw. It is divided into three columns:

- a. **Depth (msw) Column.** All depths are measured in metres of seawater (msw). Refer to CAF Air Diving Table 1S, *Short Standard Air Decompression Table*, Chapter 3, Annex A3, [Figure 3A-2](#).
- b. **A “No-decompression” Column to the Left of the Broad Vertical Line.** No-D Bottom Time (min) and a Repetitive Group (RG) designator for that depth and BT are set out in rows according to depth.
- c. **A “decompression-required” Column to the Right of the Broad Vertical Line**
 - (1) Bottom Time (min) and where applicable, a Repetitive Group (RG) designator for that depth and BT are set out in rows according to depth.
 - (2) For dive depths to 18 msw or shallower:
 - (a) Decompression stops are taken at 3 msw only.
 - (b) Decompression stop times (min) at 3 msw are set out below the 18 msw row.
 - (3) For dive depths deeper than 18 msw down to 45 msw:
 - (a) Decompression stops are taken at 6 msw and at 3 msw.
 - (b) Decompression stop times (min) at 6 msw and at 3 msw are set out below the 45 msw row.

2. **Bottom Times Without a RG.** In CAF Air Diving Table 1S where bottom times appear without a RG, repetitive diving is NOT ALLOWED.

3. **No-Decompression Limits.** No-decompression limits in CAF Air Diving Tables 1 and 1S are for first dive or single/combined dives.

4. **Stop Times, Travel Time and Ascent Rate.** Stop times are given in increments of 5 minutes and include the travel time to the stop at an ascent rate of 18 ± 3 mpm.

5. Using CAF Air Diving Table 1S

a. EXAMPLE 1

NOTE

Determine the decompression schedule for a dive to 31 msw with a bottom time of 22 minutes using CAF Air Diving Table 1S.

- (1) Enter CAF Air Diving Table 1S at the left-hand depth column at the depth equal to or next greater than 31 msw.
Select “33”
- (2) Using the 33 msw schedule, proceed horizontally across the row and find the listed bottom time equal to or next greater than 22 minutes, together with (where applicable) its RG designator.
Select “24 G” (listed BT equal to or next greater than 22 minutes and RG designator upon surfacing)

- (3) Follow the bottom time column downward to the listed decompression stop times, i.e. **6 msw** for 5 minutes and **3 msw** for 10 minutes
- (4) Decompression schedule for a dive to 31 msw with a bottom time of 22 minutes from CAF Air Diving Table 1S

33 msw / 24 min
RG = G

6 msw stop for 5-minutes (includes travel time from 31 msw)

3 msw stop for 10-minutes (includes travel time from 6 msw)

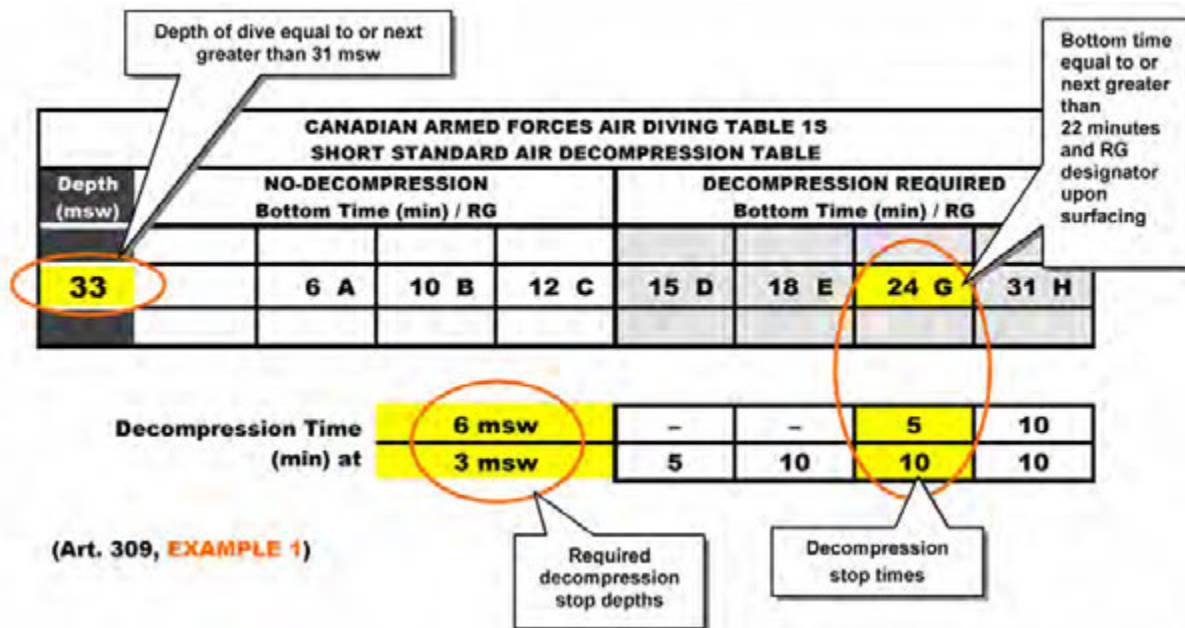

310. REPETITIVE DIVING TABLE (CAF AIR DIVING TABLES 4A AND 4B)

1. There is a quantity of residual nitrogen that remains in a diver's body after every air dive. The Repetitive Group (RG) letter assigned to the respective dive profile by either CAF Air Diving Table 1 or CAF Air Diving Table 1S expresses this quantity. This residual nitrogen will gradually reduce to a normal level over a period of eighteen (18) hours. If the diver is to make a repetitive dive within this period, the residual nitrogen level must be considered when planning for repetitive diving. Repetitive Air Diving Tables have been developed to protect the diver from the effects of residual nitrogen.

2. CAF Air Diving Table 4, *Repetitive Diving Table*, consists of two parts: CAF Air Diving Table 4A, *Repetitive Factors/Surface Intervals Table*, and CAF Air Diving Table 4B, *No-Decompression Repetitive Diving Table*. These tables permit repetitive diving only within the range of the NORMAL AIR DIVING LIMIT as outlined in [Figure 3-1](#).

a. All depths are measured in metres of seawater (msw):

- (1) CAF Air Diving Table 4A, *Repetitive Factors / Surface Intervals Table*, Chapter 3, Annex A3, [Figure 3A-3](#), and
- (2) CAF Air Diving Table 4B, *No-Decompression Repetitive Diving Table*, Chapter 3, Annex A3, [Figure 3A-3](#).

3. In CAF Air Diving Table 4A a Repetitive Factor (RF) (a two-digit number from 1.0 to 2.0) is given for each Repetitive Group (RG) letter (from A to O) at selected Surface Intervals (SI) from 15 minutes to 18 hours. As the SI increases, the RF diminishes until it becomes 1.0.

- a. A dive is considered a repetitive dive if it is conducted while the RF of the previous dive is greater than 1.0. For example, any dive within 18 hours after surfacing with a RG of H or higher, the dive would be considered a repetitive dive.
- b. The RFs in CAF Table 4A have been cut off at 2.0. It is considered that after a strenuous first dive, the SI should be sufficient in length to reduce the residual nitrogen level of the diver to that degree.
- c. If it is necessary to conduct a repetitive dive where the RF is greater than 2.0, the procedure to determine the decompression schedule is the same as when the SI is less than 15 minutes or, as described in [paragraph 12](#).

4. The RF is used to calculate the Effective Bottom Time (EBT) for the repetitive dive. The EBT is determined by multiplying the actual bottom time of the repetitive dive by the RF. It is the total of the actual bottom time plus the time considered to have been already spent at that depth (because of the residual nitrogen remaining in the body from the previous dive). The EBT is used to determine the decompression requirements for the repetitive dive.

5. In CAF Air Diving Table 4B, No-Decompression Repetitive Diving, the allowable no-decompression (“No-D”) limits for repetitive dives are shown for different depths as a function of the RF. These No-D limits are actual bottom times and not EBTs.

- a. The BTs of these repetitive allowable No-D limits are less than those No-D limits given in CAF Air Diving Tables 1 and 1S that are for first dives only.

6. For any repetitive diving, consult CAF Air Diving Table 4B to determine whether the planned dive is a no-decompression dive or whether decompression will be required.

7. **Determining the Allowable No-D Limit (min), EBT (min) and RG of a Repetitive Dive**

- a. **Determine the RG of the First Dive.** Enter CAF Air Diving Table 1 or 1S in depth column at depth equal to or greater than the depth of the first dive. Select bottom time equal to or greater than the actual bottom time. Select appropriate RG designator.
- b. **Determine the RF of the First Dive.** Enter CAF Air Diving Table 4A. Where the RG designator of first dive and appropriate SI intersect, obtain the first dive Repetitive Factor (RF).
- c. **Determine the Repetitive Dive Allowable No-D Limit (min).** Enter CAF Air Diving Table 4B in depth column at listed depth equal to or greater than the depth of the repetitive dive. The allowable No-D limit of the repetitive dive is found at the intersection of the depth row and RF column. This is actual bottom time and not EBT.
- d. **Determine the EBT of the Repetitive Dive.** The effective bottom time (min) of a repetitive dive equals the actual bottom time of the repetitive dive multiplied by the RF of the previous dive (from CAF Air Diving Table 4A):

$$\text{EBT} = \text{BT} \times \text{RF}$$

- e. **Determine the RG of the Repetitive Dive.** Enter CAF Air Diving Table 1 or 1S in the depth column at the depth equal to or greater than the depth of the repetitive dive and proceed horizontally to the bottom time equal to or next greater than the EBT. Note the repetitive dive RG designator.

NOTE

If repetitive diving is planned, refer to [paragraph 13](#), *Repetitive Group (RG) Adjustments for Repetitive Dives*.

8. A worksheet to aid in the calculation of decompression requirements for repetitive dives is provided at [Figure 3-5](#) (Repetitive Diving Worksheet).

9. No-Decompression Repetitive Dives:

a. If the actual bottom time of the repetitive dive is less than or equal to the allowable No-D limit found in CAF Air Diving Table 4B, the repetitive dive is a No-D dive.

b. **EXAMPLE 1**

NOTE

Determine the allowable No-D limit, EBT and RG for a repetitive dive to 15 msw with a bottom time of 30 minutes, following a first dive to 18 msw with a bottom time of 30 minutes and a Surface Interval (SI) of 1 hour.

(1) Enter CAF Air Diving Table 1 or 1S in depth column at depth next greater than or equal to the depth of the first dive to obtain first dive RG designator. Given: Depth^(Dive 1) = 18 msw, BT^(Dive 1) = 30 min, then using CAF Table 1S:

RG^(Dive 1) = D

CANADIAN ARMED FORCES AIR DIVING TABLE 1 STANDARD AIR DECOMPRESSION TABLE											
Depth (msw)	Bottom Time (min)	Stop Time (min) at Depth (msw)								Decom. Time (min)	RG
		24	21	18	15	12	9	6	3		
18	30	-	-	-	-	-	-	-	-	1	D

(Art. 310, part **EXAMPLE 1**)

Depth equal to or next greater than depth of first dive

BT equal to or next greater than BT of first dive

Repetitive group (RG) designator upon surfacing from first dive

(2) Enter CAF Air Diving Table 4A at repetitive group designator of first dive to obtain first dive repetitive factor. Given: RG^(Dive 1) = D, SI = 1 hr, then using CAF Table 4A:

RF^(Dive 1) = 1.4

CANADIAN ARMED FORCES AIR DIVING TABLE 4 REPETITIVE DIVING TABLE											
A. REPETITIVE FACTORS / SURFACE INTERVALS TABLE											
RG	Repetitive Factors (RF) for Surface Intervals (SI) (hr : min)										
	0:15 - 0:29	0:30 - 0:59	1:00 - 1:29	1:30 - 1:59	2:00 - 2:59	3:00 - 3:59	4:00 - 5:59	6:00 - 8:59	9:00 - 11:59	12:00 - 14:59	15:00 - 18:00
D	1.8	1.5	1.4	1.3	1.3	1.2	1.2	1.1	1.1	1.0	1.0

SI = 1 hr

Repetitive group (RG) designator of first dive from CF Air Diving Table 1

Repetitive factor (RF) of first dive

(Art. 310, part **EXAMPLE 1**)

- (3) Enter CAF Air Diving Table 4B in depth column at depth equal to or greater than or depth of the repetitive dive. The allowable No-D limit of the repetitive dive is found at the intersection of the depth row and RF column. This is actual bottom time and not EBT. Given: Depth ^(Dive 2) = 15 msw, RF ^(Dive 1) = 1.4, then using CAF Table 4B:

Allowable No-D Limit ^(Dive 2) = 45 minutes

- (4) The actual bottom time of the repetitive dive (30 minutes) is less than or equal to the allowable No-D limit (45 minutes) found in CAF Air Diving Table 4B. Therefore, the repetitive dive is a no-decompression dive.

CANADIAN ARMED FORCES AIR DIVING TABLE 4 (METRES) REPETITIVE DIVING TABLE										
B. NO-DECOMPRESSION REPETITIVE DIVING TABLE										
Depth (msw)	Allowable No-D Limits (min) for Repetitive Factors (RF)									
	1.1	1.2	1.3	1.4	1.5	1.6	1.7	1.8	1.9	2.0
15	60	55	50	45	41	38	36	34	32	31

(Art. 310, part **EXAMPLE 1**)

Depth equal to or next greater than depth of repetitive dive

Allowable No-D limit (min) of repetitive dive (actual bottom time, not EBT)

- (5) EBT is determined by multiplying the actual bottom time of the repetitive dive by the RF of the previous dive (obtained from CAF Air Diving Table 4A).

$$EBT = BT^{(Dive 2)} \times RF^{(Dive 1)} = 30 \text{ minutes} \times 1.4$$

EBT ^(Dive 2) = 42 minutes

- (6) Enter CAF Air Diving Table 1S in the depth column at the depth equal to or next greater than the depth of the repetitive dive and proceed horizontally to the bottom time equal to or next greater than the EBT. Note the repetitive dive RG designator. Given: Depth ^(Dive 2) = 15 msw, BT next \geq 42 min = 50 min, then using CAF Table 1S:

RG ^(Dive 2) = E

CANADIAN ARMED FORCES AIR DIVING TABLE 1S SHORT STANDARD AIR DECOMPRESSION TABLE								
Depth (msw)	NO-DECOMPRESSION Bottom Time (min) / RG				DECOMPRESSION REQUIRED Bottom Time (min) / RG			
	15	18 A	30 C	50 E	75 G	90 H	110 J	128 L
	25 B	40 F	60 F		100 I	120 K		

(Art. 310, part **EXAMPLE 1**)

Bottom time equal to or next greater than the 42-min EBT

RG designator upon surfacing from repetitive dive

c. Minimum Surface Interval (SI) for a No-D Repetitive Dive

(1) EXAMPLE 2

NOTE

Determine the minimum SI (min) required following a first dive to 24 msw with a bottom time of 25 minutes, with a repetitive dive to 15 msw with a planned bottom time of 50 minutes.

- (a) Enter CAF Air Diving Table 4B in depth column at depth equal to or greater than the depth of the repetitive dive and proceed horizontally to the bottom time equal to or greater than the intended bottom time. Proceed upward in the column to find the RF for the repetitive dive. Given: Depth^(Dive 2) = 15 msw, BT^(Dive 2) = 50 min), then using CAF Table 4B:

RF^(Dive 2) = 1.3

CANADIAN ARMED FORCES AIR DIVING TABLE 4 REPETITIVE DIVING TABLE										
B. NO-DECOMPRESSION REPETITIVE DIVING TABLE										
Depth (msw)	Allowable No-D Limits (min) for Repetitive Factors (RF)									
	1.1	1.2	1.3	1.4	1.5	1.6	1.7	1.8	1.9	2.0
15	60	55	50	45	41	38	36	34	32	31

Depth equal to or greater than the depth of the repetitive dive

BT equal to or greater than the bottom time of the repetitive dive

(Art. 310, part EXAMPLE 2)

- (b) Enter CAF Air Diving Table 4A at the RG of the previous dive.

RG^(Dive 1) = E (from CAF Air Diving Table 1 or 1S)

- (c) Proceed horizontally to the required RF.

RF^(Dive 2) = 1.3 (from CAF Air Diving Table 4B)

- (d) Proceed upward in the column to determine the minimum SI required:

Minimum SI = 2 hours

CANADIAN ARMED FORCES AIR DIVING TABLE 4 REPETITIVE DIVING TABLE											
A. REPETITIVE FACTORS / SURFACE INTERVALS TABLE											
RG	Repetitive Factors (RF) for Surface Intervals (SI) (hr : min)										
	0:15 -- 0:29	0:30 -- 0:59	1:00 -- 1:29	1:30 -- 1:59	2:00 -- 2:59	3:00 -- 3:59	4:00 -- 5:59	6:00 -- 8:59	9:00 -- 11:59	12:00 -- 14:59	15:00 -- 18:00
E	1.9	1.6	1.5	1.4	1.3	1.3	1.2	1.2	1.1	1.1	1.0

Minimum SI = 2 hrs

(Art. 310, part EXAMPLE 2)

National Défense
 Defence nationale

CANADIAN ARMED FORCES AIR DIVING TABLES REPETITIVE DIVING WORKSHEET (METRES)

FIRST DIVE

_____ msw _____ min Table Used _____
 1st Dive Repetitive Group RG _____ (CF Table 1 or 1S)

SECOND DIVE

SI _____ hr _____ min RF _____ (CF Table 4A)
 Depth _____ msw Table Used _____

Allowable No-D Limit _____ min (CF Table 4B)
 Bottom Time (BT) _____ min
 Decompression Required? YES NO _____
 RF _____ x BT _____ = _____ min EBT

DECOMPRESSION SCHEDULE

	msw		min
	msw		min
	msw		min
	msw		min
	msw		min

Repetitive Dive RG _____ (from Table Used)
 Adjusted Repetitive Dive RG _____

NOTES

- 1) If the BT exceeds the allowable No-D limit in Table 4B but the EBT is less than the No-D limit in CF Air Diving Tables 1, 1S, 2, 2S or 3, then a 3 msw for 5-minute air decompression stop is required.
- 2) The RG shall be adjusted to the same as that of the decompression schedule requiring the 3 msw for 5-minute stop.

Y583FP0045-00

Figure 3-5 Repetitive Diving Worksheet (Metres)

10. Repetitive Dives Requiring Decompression

a. If the actual bottom time of the repetitive dive is greater than the allowable No-D limit shown in CAF Air Diving Table 4B, the repetitive dive requires decompression.

b. EXAMPLE 3

NOTE

Is decompression required for a repetitive dive to 33 msw with a bottom time of 10 minutes, following a previous dive to 33 msw with a bottom time of 15 minutes, SI of 40 minutes?

(1) Obtain the RG of the previous dive from CAF Air Diving Table 1 or 1S. Given: Depth ^(Dive 1) = 33, BT ^(Dive 1) = bottom time equal to or next greater than 15 minutes, then using CAF Table 1:

RG ^(Dive 1) = D

CANADIAN ARMED FORCES AIR DIVING TABLE 1 STANDARD AIR DECOMPRESSION TABLE											
Depth (msw)	Bottom Time (min)	Stop Time (min) at Depth (msw)								Decom. Time (min)	RG
		24	21	18	15	12	9	6	3		
33	15	-	-	-	-	-	-	-	5	5	D

Depth of previous dive (points to 33)

BT bottom time equal to or next greater than 15 minutes (points to 15)

(Art. 310, part EXAMPLE 3)

RG of previous dive (points to D)

(2) Enter CAF Air Diving Table 4A at the RG designator of the previous dive to obtain the RF using the given: RG ^(Dive 1) = D, SI = 40 min, then using CAF Table 4A:

RF ^(Dive 1) = 1.5

CANADIAN ARMED FORCES AIR DIVING TABLE 4 REPETITIVE DIVING TABLE											
A. REPETITIVE FACTORS / SURFACE INTERVALS TABLE											
RG	Repetitive Factors (RF) for Surface Intervals (SI) (hr : min)										
	0:15 - 0:29	0:30 - 0:59	1:00 - 1:29	1:30 - 1:59	2:00 - 2:59	3:00 - 3:59	4:00 - 5:59	6:00 - 8:59	9:00 - 11:59	12:00 - 14:59	15:00 - 18:00
D	1.8	1.5	1.4	1.3	1.3	1.2	1.2	1.1	1.1	1.0	1.0

RF of previous dive (points to 1.5)

(Art. 310, part EXAMPLE 3)

- (3) Per CAF Air Diving Table 4B, for a repetitive dive to 33 msw when RF (Dive 1) = 1.5, the allowable No-D limit is 7 minutes.

Allowable No-D limit of repetitive dive = 7 minutes

CANADIAN ARMED FORCES AIR DIVING TABLE 4 REPETITIVE DIVING TABLE										
B. NO-DECOMPRESSION REPETITIVE DIVING TABLE										
Depth (msw)	Allowable No-D Limits (min) for Repetitive Factors (RF)									
	1.1	1.2	1.3	1.4	1.5	1.6	1.7	1.8	1.9	2.0
33	10	9	8	8	7	7	6	6	6	6

(Art. 310, part **EXAMPLE 3**)

Allowable No-D limit of repetitive dive

- (4) Bottom time of the repetitive dive (10 minutes) is greater than the allowable No-D limit shown in CAF Air Diving Table 4B (7 minutes). Therefore, the repetitive dive requires decompression.

- (5) Determine the EBT by multiplying the bottom time of the repetitive dive by the RF of the previous dive.

$$EBT = BT_{(Dive\ 2)} \times RF_{(Dive\ 1)} = 10\ \text{minutes} \times 1.5$$

EBT = 15 minutes

- (6) Enter CAF Air Diving Table 1S. Determine the decompression schedule using the repetitive dive depth and the EBT.

33 msw / 15 min

- (7) Determine decompression stop required for this repetitive dive.

3 msw stop for 5-minutes

CANADIAN ARMED FORCES AIR DIVING TABLE 1 STANDARD AIR DECOMPRESSION TABLE											
Depth (msw)	Bottom Time (min)	Stop Time (min) at Depth (msw)								Decom. Time (min)	RG
		24	21	18	15	12	9	6	3		
33	15	-	-	-	-	-	-	-	5	5	D

Depth of repetitive dive

EBT

Time at stop

(Art. 310, part **EXAMPLE 3**)

11. **Repetitive Bottom Times exceeding the Allowable No-D Limits in CAF Air Diving Table 4B but with EBTs less than the No-D Limits in CAF Air Diving Tables 1 and 1S**

- a. For repetitive bottom times exceeding the Allowable No-D limits in CAF Air Diving Table 4B but with EBTs less than the No-Decompression Limits in CAF Air Diving Tables 1 and 1S a **3 msw decomposition stop** for 5-minute is **mandatory**.
- b. The No-D limits in CAF Air Diving Tables 1 and 1S are for **first dives only**.
- c. The repetitive group (RG) shall be adjusted to the same as that of the decomposition schedule requiring the **3 msw stop** for 5-min.
- d. **EXAMPLE 4**

NOTE

Is decompression required for a repetitive dive to 18 msw with a bottom time of 30 minutes, following a previous dive to 18 msw with a bottom time of 50 minutes, SI of 1 hour 45 minutes?

- (1) Obtain the RG of the previous dive from CAF Air Diving Table 1 or 1S.

RG (Dive 1) = **F**

CANADIAN ARMED FORCES AIR DIVING TABLE 1S SHORT STANDARD AIR DECOMPRESSION TABLE								
Depth (msw)	NO-DECOMPRESSION Bottom Time (min) / RG				DECOMPRESSION REQUIRED Bottom Time (min) / RG			
	18	14 A 20 B	25 C 30 D	40 E	50 F	60 G	70 H 80 I	88 J

(Art. 310, part **EXAMPLE 4**)

Bottom time equal to or next greater than previous dive 50-min

RG designator of previous dive

- (2) Enter CAF Air Diving Table 4A at the RG designator of the previous dive to obtain the RF using the given: RG (Dive 1) = F, SI = 1 hour 45 minutes, then using CAF Table 4A:

RF (Dive 1) = **1.5**

CANADIAN ARMED FORCES AIR DIVING TABLE 4 REPETITIVE DIVING TABLE											
REPETITIVE FACTORS / SURFACE INTERVALS TABLE											
RG	Repetitive Factors (RF) for Surface Intervals (SI) (hr : min)										
	0:15 - 0:29	0:30 - 0:59	1:00 - 1:29	1:30 - 1:59	2:00 - 2:29	3:00 - 3:59	4:00 - 5:59	6:00 - 8:59	9:00 - 11:59	12:00 - 14:59	15:00 - 18:00
F	2.0	1.7	1.6	1.5	1.4	1.3	1.3	1.2	1.1	1.1	1.0

(Art. 310, part **EXAMPLE 4**)

RG of previous dive

SI = 1:45

RF of previous dive

- (3) Per CAF Air Diving Table 4B, for a repetitive dive to a depth of 18 msw when RF (Dive 1) = 1.5, the allowable No-D limit of this dive = 27 minutes.

Allowable No-D limit = 27 minutes

CANADIAN ARMED FORCES AIR DIVING TABLE 4 REPETITIVE DIVING TABLE										
B. NO-DECOMPRESSION REPETITIVE DIVING TABLE										
Depth (msw)	Allowable No-D Limits (min) for Repetitive Factors (RF)									
	1.1	1.2	1.3	1.4	1.5	1.6	1.7	1.8	1.9	2.0
18	40	35	31	29	27	26	24	23	22	21

(Art. 310, part **EXAMPLE 4**)

Allowable No-D limit of the repetitive dive

- (4) Bottom time of the **repetitive** dive (30 minutes) is greater than the allowable No-D limit shown in CAF Air Diving Table 4B (27 minutes). Therefore, the repetitive dive requires decompression.
- (5) Determine EBT by multiplying the bottom time of the **repetitive** dive by the RF of the **previous** dive.
 $EBT = BT \text{ (min)}^{(Dive 2)} \times RF^{(Dive 1)}$
 $EBT = 30 \text{ minutes} \times 1.5$
EBT = 45 minutes
- (6) EBT (45 minutes) is less than the No-Decompression Limit (50 minutes) shown in CAF Air Diving Table 1S.
- (a) A **3 msw decompression stop** for 5-minutes is **mandatory**.
- (b) The No-D limits in CAF Air Diving Tables 1 and 1S are for **first dives only**.

CANADIAN ARMED FORCES AIR DIVING TABLE 1S SHORT STANDARD AIR DECOMPRESSION TABLE								
Depth (msw)	NO-DECOMPRESSION Bottom Time (min) / RG				DECOMPRESSION REQUIRED Bottom Time (min) / RG			
	18	14 A 20 B	25 C 30 D	40 E	50 F	60 G	70 H 80 I	88 J

(Art. 310, part **EXAMPLE 4**)

No-D limit (minutes) equal to or next greater than EBT

RG adjusted to the same as that of the deco schedule requiring 3msw stop for 5 min

12. **Surface Intervals Less than 15 Minutes**

a. **The procedure to determine the decompression schedule** when the SI is less than 15 minutes between dives is as follows:

- (1) Take the deepest depth of the dives.
- (2) Add the bottom times together to obtain the EBT.
- (3) Determine the decompression schedule by using the deepest depth and combined bottom times

b. **EXAMPLE 5**

NOTE

Determine the decompression schedule for a dive to 18 msw with a bottom time of 20 minutes, surface interval of 10 minutes, followed by a dive to 15 msw with a bottom time of 25 minutes.

- (1) Deepest depth achieved during both dives = 18 msw
- (2) SI = 10 minutes. SI < 15, therefore $EBT^{(Dive\ 2)} = BT^{(Dive\ 1)} + BT^{(Dive\ 2)} = 20\ \text{minutes} + 25\ \text{minutes} = 45\ \text{minutes}$

EBT = 45 minutes

(3) Decompression schedule from CAF Air Diving Table 1S:

18 msw / 50 min

RG = F

No Decompression Required

CANADIAN ARMED FORCES AIR DIVING TABLE 1S SHORT STANDARD AIR DECOMPRESSION TABLE								
Depth (msw)	NO-DECOMPRESSION Bottom Time (min) / RG				DECOMPRESSION REQUIRED Bottom Time (min) / RG			
18	14 A 20 B	25 C 30 D	40 E	50 F	60 G	70 H 80 I	88 J	95 K

(Art. 310, part **EXAMPLE 5**)

13. Repetitive Group (RG) Adjustments

- a. Repetitive dive tables have fixed limits and cannot take into account every possible diving situation. Repetitive Group adjustments may be required in some cases after a repetitive dive. These adjustments are necessary to eliminate the potential for decompression related ailments (DCS, omitted D and flying after diving).
- b. If a series of similar no-decompression repetitive dives are conducted (*i.e.* similar depth/bottom time/surface interval) it is possible to get locked into a loop resulting in the same RG and RF after each dive. Because decompression will eventually be required it is necessary to adjust the RG to break out of this loop. Similarly, if a short duration dive follows a dive with a longer bottom time, the RG calculated for the second dive will be too small and will not take into account the influence of the longer first dive. The second dive RG must be adjusted.
- c. Whenever repetitive dives are conducted, determine the RG that corresponds to the depth and EBT of the just-completed repetitive dive using the appropriate decompression table (CAF Air Diving Table 1 or 1S).
- d. If an RG adjustment is required, it must be recorded on the Repetitive Dive Worksheet as the Adjusted Repetitive Group. This adjusted RG shall be used for subsequent planning. *i.e.* Repetitive diving and flying after diving etc.

e. Making Repetitive Group (RG) Adjustments

- (1) If the RG of the just completed dive is **greater than** the RG of the previous dive, no adjustment is necessary. For example:

Previous dive's RG = D
Just-completed dive's RG = E
E > D

NO RG ADJUSTMENT REQUIRED.

If the RG of the just completed dive is **lower than or equal to** the RG of the previous dive and the surface interval is **less than six hours**, adjust the just-completed dive's RG by one letter greater than the previous dives RG. This is now the **adjusted RG**. For example:

Previous dive's RG = D
Just-completed dive's RG = B
SI < 6 hrs
B ≤ D

RG ADJUSTMENT IS REQUIRED. The Adjusted RG of the just-completed dive is now "E" (*i.e.* D + 1 letter).

- (2) If the RG of the just completed dive is **lower than or equal to** the RG of the previous dive and the surface interval is **more than six hours**, adjust the RG of the **just-completed** dive upward by one letter. This is now the **adjusted RG** for the just-completed dive. For example:

Previous dive's RG = D
Just-completed dive's RG = B
SI > 6 hrs
B ≤ D

RG ADJUSTMENT IS REQUIRED. The Adjusted RG of the just-completed dive is now C (*i.e.* B + 1 letter).

14. Refer to [Figure 3-6](#), *CAF Air Diving Tables Repetitive Diving Flowchart*, for aid in the use of repetitive diving procedures.



CANADIAN ARMED FORCES AIR DIVING TABLES REPETITIVE DIVING

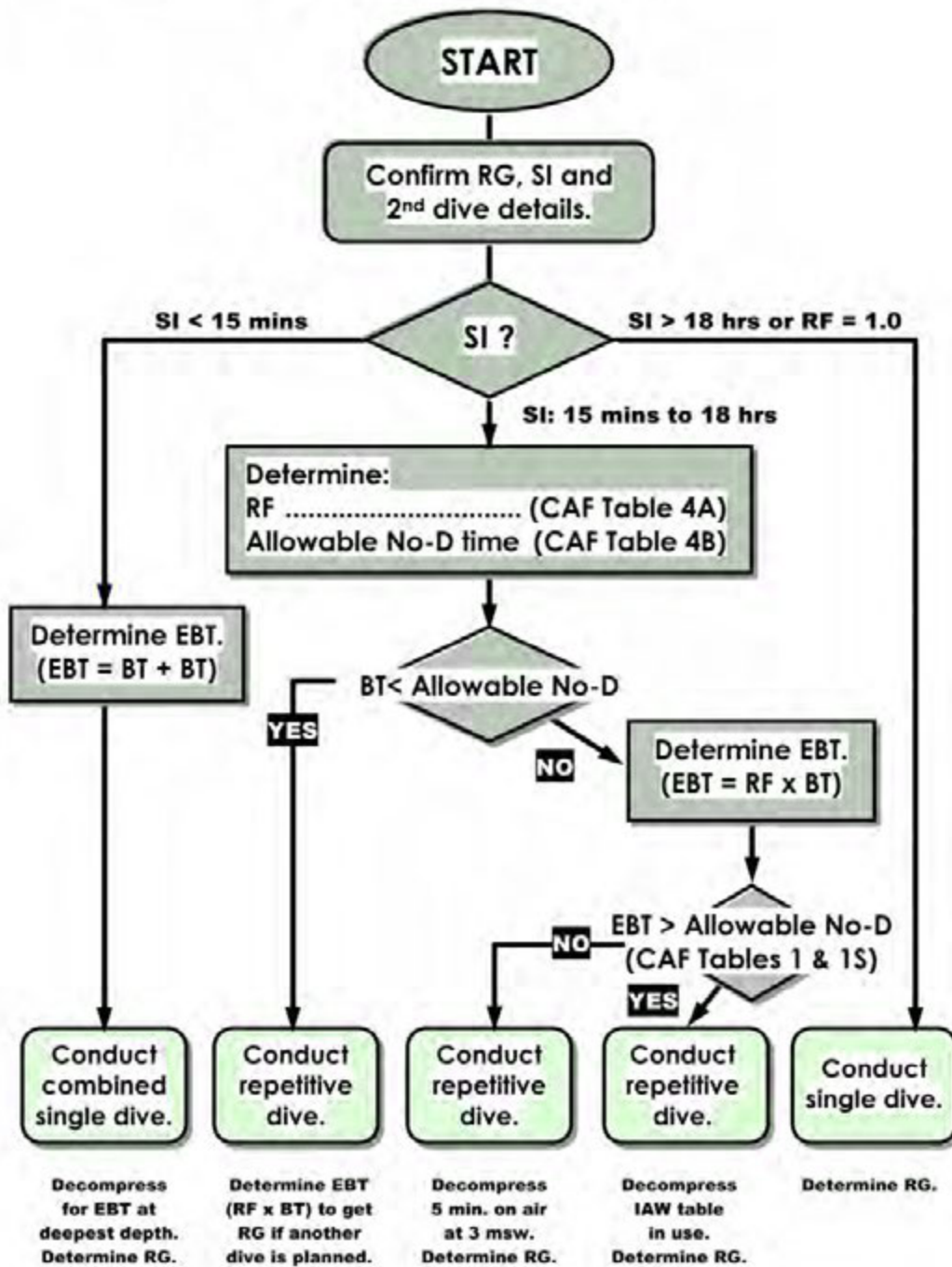

Y583FP0055-00

Figure 3-6 CAF Air Diving Tables Repetitive Diving Flowchart

311. DEPTH CORRECTIONS FOR DIVING AT ALTITUDE TABLE (CAF AIR DIVING TABLE 5)

1. CAF Air Diving Table 5, *Depth Corrections for Diving at Altitude Table*, provides tabulated depth corrections for determining decompression profiles and decompression stop depths when diving in elevated areas above sea level. These corrections are necessary because the surface pressure and the underwater absolute pressure are less at altitude. Of particular significance is that diving tables and decompression techniques are designed to return a diver safely to a sea level pressure and not to a lesser pressure as found at altitude. This reduced atmospheric pressure at the surface makes the dive at altitude equivalent to a deeper dive at sea level.
2. The *Depth Corrections for Diving at Altitude Table* has been developed accordingly to resolve these differences by providing depth corrections for selected altitudes up to 3000 metres. These depth corrections are added to the actual depth to determine the dive profile to be used for decompression purposes. In addition, the table sets out the actual stop depths to be used in place of the standard decompression stops.

NOTE

Divers are cautioned that diver's depth gauges may not read "actual" water depth at altitudes. The diver's digital depth gauge measures the diving depth independently of air pressure and is therefore much more precise. Shot lines or hand held depth sounders should be used to sound the depth.

3. All *depths* are measured in metres of seawater (msw). Refer to CAF Air Diving Table 5 (METRES), *Depth Corrections for Diving at Altitude*, Chapter 3, Annex A3, [Figure 3A-4](#).
4. **Using CAF Air Diving Table 5**
 - a. Establish the altitude of the dive site in metres.
 - b. Determine the actual maximum water depth of the dive in metres.
 - c. Determine acclimatization factor, if any.
 - (1) Due to acclimatization effect, if diving at altitude is conducted within 24 hours after arrival at the dive site, then apply an additional 3 metres to the actual maximum depth of the dive. Use the adjusted depth to obtain the depth correction from CAF Air Diving Table 5.
 - (2) Once past the 24-hour acclimatization period, the 3 metres addition is not required.
 - d. Find the correction for the actual depth according to the altitude from CAF Air Diving Table 5 and add this correction to the actual depth to obtain the effective depth (ED).
 - e. Determine the decompression schedule from the appropriate decompression table by applying the ED and the actual planned bottom time.
 - f. Replace the decompression stop depths from the normal decompression table with the stop depths shown under Actual Decompression Stop Depth at Altitude, CAF Air Diving Table 5. The stop times are not changed.
 - g. Decompress on this altitude schedule IAW normal procedures using regular travel rates.
 - h. Worksheets to assist in the calculation of decompression requirements for diving at altitude are provided at [Figure 3-7](#), *Altitude Diving Worksheet (METRES)*

i. **EXAMPLE 1**

NOTE

Determine the decompression schedule for a dive to 30 msw with a bottom time of 20 minutes at an altitude of 2180 metres. The diver is acclimatized.

- (1) Establish the altitude of the dive site (metres): **2180 m**.
- (2) Determine actual maximum water depth of the dive: **30 msw**.
- (3) Determine the acclimatization factor, if any: **NIL**.
 - (a) Diver is acclimatized, *i.e.* diver has been at dive site altitude longer than the 24-hour acclimatization period. The 3-meters acclimatization factor is therefore not required.
- (4) Find dive depth correction according to depth/altitude from CAF Air Diving Table 5.
 - (a) Dive depth correction, 30 msw dive at 2180 m: **+9 msw**.

CANADIAN ARMED FORCES AIR DIVING TABLE 5 DEPTH CORRECTIONS FOR DIVING AT ALTITUDE TABLE									
Depth (msw)	Depth Correction at Altitude								
	100	300	600	900	1200	1500	1800	2100	2400
	- 299	- 599	- 899	- 1199	- 1499	- 1799	- 2099	- 2399	- 3000
30	+0	+3	+3	+6	+6	+9	+9	+9	+12

(Art. 311, part **EXAMPLE 1**)

- (5) Determine effective depth (ED):

ED = Actual depth of dive + acclimatization factor, if any + dive depth correction = 30 msw + (NIL) + 9 msw

ED = 39 msw
- (6) Determine the decompression schedule from CAF Air Diving Table 1 or 1S for the repetitive dive ED and bottom time (20 minutes). Dive profile ED/BT = 39 msw / 20 min. Decompression schedule required (from CAF Air Diving Table 1S):

39 msw / 21 min

CANADIAN ARMED FORCES AIR DIVING TABLE 1S (METRES) SHORT STANDARD AIR DECOMPRESSION TABLE								
Depth (msw)	NO-DECOMPRESSION Bottom Time (min) / RG				DECOMPRESSION REQUIRED Bottom Time (min) / RG			
	39			5 A	8 B	10 C	13 D	17 F

(Art. 311, part **EXAMPLE 1**)

- (7) Replace the decompression stop depths from the normal decompression table with the stop depths shown under “Actual Decompression Stop Depth at Altitude”, CAF Air Diving Table 5. The stop times are **not** changed.

CANADIAN ARMED FORCES AIR DIVING TABLE 5 DEPTH CORRECTIONS FOR DIVING AT ALTITUDE TABLE									
Sea Level Stop Depth (msw)	Actual Decompression Stop Depth at Altitude								
	100 – 299	300 – 599	600 – 899	900 – 1199	1200 – 1499	1500 – 1799	1800 – 2099	2100 – 2399	2400 – 3000
3	3.0	3.0	3.0	3.0	2.5	2.5	2.5	2.5	2.5
6	6.0	6.0	6.0	5.5	5.5	5.0	5.0	5.0	4.5
9	9.0	9.0	8.5	8.0	7.5	7.5	7.0	7.0	7.0

(Art. 311, part **EXAMPLE 1**)

Altitude of dive site

Adjusted stop depths

CANADIAN ARMED FORCES AIR DIVING TABLE 1S (METRES) SHORT STANDARD AIR DECOMPRESSION TABLE								
Depth (msw)	NO-DECOMPRESSION Bottom Time (min) / RG				DECOMPRESSION REQUIRED Bottom Time (min) / RG			
			5 A	8 B	10 C	13 D	17 F	21 G
39								
Decompression Time			6 msw		-	-	5	10
(min) at			3 msw		5	10	10	10

(Art. 311, part **EXAMPLE 1**)

- (8) Decompress on this altitude schedule IAW normal procedures using standard rates of travel.

5. The example below illustrates the completion of a sample Altitude Diving Worksheet when the diver is acclimatized, *i.e.* the diver has been at dive site altitude longer than the 24-hour acclimatization period. The 3-metre acclimatization factor is therefore NOT REQUIRED.

DIVER IS ACCLIMATIZED

CANADIAN ARMED FORCES AIR DIVING TABLES ALTITUDE DIVING WORKSHEET	
Altitude of dive site	<u>2180</u> metres
Actual depth of dive	(A) <u>30</u> msw
Acclimatization factor (+3 msw if < 24 hrs)	(B) <u>NIL</u> msw
A + B = C (Depth for CAF Table 5)	(C) <u>30</u> msw
Dive depth correction* (CAF Air Diving Table 5)	(D) <u>9</u> msw
Effective depth (ED) (C + D)	<u>39</u> msw
Bottom time (BT)	<u>20</u> min
Dive Profile (ED / BT)	<u>39</u> msw <u>20</u> min
Decompression Schedule from CAF Air Diving Table <u>15</u>	<u>39</u> msw <u>21</u> min

ALTITUDE DIVE DECOMPRESSION STOPS		
Sea Level Stop Depth (msw)	Actual Stop Depth (msw)	Stop Time (min)
12	msw	min
9	msw	min
6	<i>5.0</i> msw	<i>10</i> min
3	<i>2.5</i> msw	<i>10</i> min
Oxygen	msw	min
Repetitive Group (RG) = <i>G</i>		

* If the diver has been at the altitude of the dive site for less than 24 hours, find the dive depth correction by first adding the acclimatization factor to the actual depth of the dive. Enter CAF Air Diving Table 5 at that depth to obtain depth correction.

6. The example below illustrates the completion of a sample Altitude Diving Worksheet when the diver is NOT acclimatized, i.e. the diver has been at dive site altitude less than the 24-hour acclimatization period. The 3-metre acclimatization factor is therefore REQUIRED.

DIVER IS NOT ACCLIMATIZED

CANADIAN ARMED FORCES AIR DIVING TABLES ALTITUDE DIVING WORKSHEET	
Altitude of dive site	<u>2180</u> metres
Actual depth of dive	(A) <u>30</u> msw
Acclimatization factor (+3 msw if < 24 hrs)	(B) <u>3</u> msw
A + B = C (Depth for CAF Table 5)	(C) <u>33</u> msw
Dive depth correction* (CAF Air Diving Table 5)	(D) <u>12</u> msw
Effective depth (ED) (C + D)	<u>45</u> msw
Bottom time (BT)	<u>23</u> min
Dive Profile (ED / BT)	<u>45</u> msw <u>15</u> min
Decompression Schedule from CAF Air Diving Table <u>15</u>	<u>45</u> msw <u>16</u> min

Diver NOT acclimatized: 3-metre acclimatization factor is REQUIRED.

ALTITUDE DIVE DECOMPRESSION STOPS		
Sea Level Stop Depth (msw)	Actual Stop Depth (msw)	Stop Time (min)
12	<u>9.5</u> msw	<u> </u> min
9	<u>7.0</u> msw	<u> </u> min
6	<u>5.0</u> msw	<u>10</u> min
3	<u>2.5</u> msw	<u>10</u> min
Oxygen	msw	min
Repetitive Group (RG) = <u>G</u>		

* If the diver has been at the altitude of the dive site for less than 24 hours, find the dive depth correction by first adding the acclimatization factor to the actual depth of the dive. Enter CAF Air Diving Table 5 at that depth to obtain depth correction.



CANADIAN ARMED FORCES AIR DIVING TABLES ALTITUDE DIVING WORKSHEET (METRES)	
Altitude of dive site	_____ metres
Actual depth of dive	(A) _____ msw
Acclimatization factor (+3 msw if < 24 hrs)	(B) _____ msw
A + B = C (Depth for CAF Table 5)	(C) _____ msw
Dive depth correction* (CAF Air Diving Table 5 (METRES))	(D) _____ msw
Effective depth (ED) (C + D)	_____ msw
Bottom time (BT)	_____ min
Dive Profile (ED / BT)	_____ msw _____ min
Decompression Schedule from CAF Air Diving Table ____	_____ msw _____ min

ALTITUDE DIVE DECOMPRESSION STOPS		
Sea Level Stop Depth (msw)	Actual Stop Depth (msw)	Stop Time (min)
12	_____ msw	_____ min
9	_____ msw	_____ min
6	_____ msw	_____ min
3	_____ msw	_____ min
Oxygen	_____ msw	_____ min
Repetitive Group (RG) =		

* If the diver has been at the altitude of the dive site for less than 24 hours, find the dive depth correction by first adding the acclimatization factor to the actual depth of the dive. Enter CAF Air Diving Table 5 at that depth to obtain depth correction.

Y583FP0061-00

Figure 3-7 Altitude Diving Worksheet (Metres)

312. DIVING AND SNORTING SUBMARINES

1. For no-decompression dives to 15 msw or less, if it is intended to snort within 2 hours of the diver returning to the surface, the instructions in [Article 310](#) for an acclimatized diver should be used. Thus, no-decompression dives should be considered as if they were being conducted at a depth 3 msw deeper than the actual depth of the dive (depth correction for altitudes from 600 – 899 metres in CAF Air Diving Table 5).

- a. For example, a dive to 15 msw would be conducted as if it were at 18 msw. If the surface interval between the completion of the dive and the submarine shutdown or snorting is greater than two hours, no depth correction need be applied.

2. For decompression dives and dives deeper than 15 msw, the instructions for non-acclimatized divers (refer to [Article 310](#)) should be applied because of the greater gas uptake. This imposes an additional 3-metre correction to that in CAF Air Diving Table 5. Thus the dive should be considered as being conducted at a depth 6 msw deeper than the actual depth. The surface interval as discussed in [paragraph 1](#) shall not be applied in this situation.

313. FLYING AFTER DIVING

1. Before flying after a No-D dive allow enough surface interval time, based on the highest RG achieved and applied after the last dive, for the RF to diminish to 1.0. For example:

- a. The diver completes three No-D repetitive dives with RGs of E, F and B respectively.
- b. The diver commences surface interval time from the just completed dive at 0800 hrs.
- c. The diver’s time to fly will be based on the highest RG achieved (*i.e.* “F”) with the surface interval (SI) starting at 0800 hrs (time when surfaced from last dive).
- d. The diver will be clear to fly (*i.e.* RF = 1.0) in 15 hours (2300 hrs clock time).

CANADIAN ARMED FORCES AIR DIVING TABLE 4 REPETITIVE DIVING TABLE											
A. REPETITIVE FACTORS / SURFACE INTERVALS TABLE											
RG	Repetitive Factors (RF) for Surface Intervals (SI) in hr : min										
	0:15 – 0:29	0:30 – 0:59	1:00 – 1:29	1:30 – 1:59	2:00 – 2:59	3:00 – 3:59	4:00 – 5:59	6:00 – 8:59	9:00 – 11:59	12:00 – 14:59	15:00 – 18:00
F			1.6	1.5	1.4	1.3	1.3	1.2	1.1	1.1	1.0

2. After No-D dives to a maximum depth of 15 msw for search and rescue operations or training, flying immediately after diving is permitted to a maximum altitude of 600 metres MSL.

- a. The aircraft that will transport the divers must carry oxygen in case of DCI. The quantity of oxygen should be sufficient to allow oxygen breathing for all divers throughout the flight.

3. After a decompression dive a minimum SI of 24 hours is required before flying.

314. HYPOBARIC CHAMBER DUTIES

1. Hypobaric chamber inside duties will not be performed within 48 hours of the completion of any dive.

ANNEX A3

CANADIAN ARMED FORCES AIR DIVING TABLES (METRES)

NOTE

These tables cover only bottom times to the limit of the Normal Air Diving Range as shown in [Figure 3-1](#). Exceptional exposure depth ranges and bottom times are excluded.

Depth (msw)	Bottom Time (min)	Stop Times (min) at Different Depths (msw)								Decom. Time (min)	Repet. Group
		24	21	18	15	12	9	6	3		
6	30	-	-	-	-	-	-	-	-	1	A
	60	-	-	-	-	-	-	-	-	1	B
	90	-	-	-	-	-	-	-	-	1	C
	120	-	-	-	-	-	-	-	-	1	D
	150	-	-	-	-	-	-	-	-	1	E
	180	-	-	-	-	-	-	-	-	1	F
	240	-	-	-	-	-	-	-	-	1	G
	300	-	-	-	-	-	-	-	-	1	H
	360	-	-	-	-	-	-	-	-	1	I
	420	-	-	-	-	-	-	-	-	1	J
	480	-	-	-	-	-	-	-	-	1	K
	600	-	-	-	-	-	-	-	-	1	L
720	-	-	-	-	-	-	-	-	1	M	
9	30	-	-	-	-	-	-	-	-	1	A
	45	-	-	-	-	-	-	-	-	1	B
	60	-	-	-	-	-	-	-	-	1	C
	90	-	-	-	-	-	-	-	-	1	D
	100	-	-	-	-	-	-	-	-	1	E
	120	-	-	-	-	-	-	-	-	1	F
	150	-	-	-	-	-	-	-	-	1	G
	180	-	-	-	-	-	-	-	-	1	H
	190	-	-	-	-	-	-	-	-	1	I
	210	-	-	-	-	-	-	-	-	1	J
	240	-	-	-	-	-	-	-	-	1	K
	270	-	-	-	-	-	-	-	-	1	L
	300	-	-	-	-	-	-	-	-	1	M
	330	-	-	-	-	-	-	-	3	3	N
	360	-	-	-	-	-	-	-	5	5	O
	400	-	-	-	-	-	-	-	7	7	
	420	-	-	-	-	-	-	-	10	10	
450	-	-	-	-	-	-	-	15	15		
480	-	-	-	-	-	-	-	20	20		

Figure 3A-1 (Sheet 1 of 15) CAF Air Diving Table 1 (Metres) – Standard Air Decompression Table

Depth (msw)	Bottom Time (min)	Stop Times (min) at Different Depths (msw)								Decom. Time (min)	Repet. Group	
		24	21	18	15	12	9	6	3			
12	20	-	-	-	-	-	-	-	-	1	A	
	30	-	-	-	-	-	-	-	-	1	B	
	40	-	-	-	-	-	-	-	-	1	C	
	60	-	-	-	-	-	-	-	-	1	D	
	70	-	-	-	-	-	-	-	-	1	E	
	80	-	-	-	-	-	-	-	-	1	F	
	90	-	-	-	-	-	-	-	-	1	G	
	120	-	-	-	-	-	-	-	-	1	H	
	130	-	-	-	-	-	-	-	-	1	I	
	150	-	-	-	-	-	-	-	-	1	J	
	160	-	-	-	-	-	-	-	-	3	K	
	170	-	-	-	-	-	-	-	-	4	L	
	180	-	-	-	-	-	-	-	-	5	M	
	200	-	-	-	-	-	-	-	-	10	10	
	210	-	-	-	-	-	-	-	-	15	15	
	220	-	-	-	-	-	-	-	-	19	19	
	240	-	-	-	-	-	-	-	-	26	26	
	270	-	-	-	-	-	-	-	-	35	35	
	300	-	-	-	-	-	-	-	-	44	44	
330	-	-	-	-	-	-	-	-	53	53		
360	-	-	-	-	-	-	-	-	62	62		

Figure 3A-1 (Sheet 2 of 15) CAF Air Diving Table 1 (Metres) – Standard Air Decompression Table

Depth (msw)	Bottom Time (min)	Stop Times (min) at Different Depths (msw)								Decom. Time (min)	Repet. Group
		24	21	18	15	12	9	6	3		
15	10	-	-	-	-	-	-	-	-	1	A
	20	-	-	-	-	-	-	-	-	1	B
	30	-	-	-	-	-	-	-	-	1	C
	40	-	-	-	-	-	-	-	-	1	D
	50	-	-	-	-	-	-	-	-	1	E
	60	-	-	-	-	-	-	-	-	1	F
	75	-	-	-	-	-	-	-	-	1	G
	90	-	-	-	-	-	-	-	3	3	H
	100	-	-	-	-	-	-	-	5	5	I
	110	-	-	-	-	-	-	-	8	8	J
	120	-	-	-	-	-	-	-	10	10	K
	130	-	-	-	-	-	-	-	16	16	L
	140	-	-	-	-	-	-	-	21	21	M
	150	-	-	-	-	-	-	-	26	26	
	160	-	-	-	-	-	-	-	31	31	
	170	-	-	-	-	-	-	-	35	35	
	180	-	-	-	-	-	-	-	40	40	
	200	-	-	-	-	-	-	-	50	50	
220	-	-	-	-	-	-	-	59	59		
240	-	-	-	-	-	-	-	70	70		
260	-	-	-	-	-	-	-	81	81		
280	-	-	-	-	-	-	-	91	91		

Figure 3A-1 (Sheet 3 of 15) CAF Air Diving Table 1 (Metres) – Standard Air Decompression Table

Depth (msw)	Bottom Time (min)	Stop Times (min) at Different Depths (msw)								Decom. Time (min)	Repet. Group
		24	21	18	15	12	9	6	3		
18	10	-	-	-	-	-	-	-	-	1	A
	20	-	-	-	-	-	-	-	-	1	B
	25	-	-	-	-	-	-	-	-	1	C
	30	-	-	-	-	-	-	-	-	1	D
	40	-	-	-	-	-	-	-	-	1	E
	50	-	-	-	-	-	-	-	-	1	F
	60	-	-	-	-	-	-	-	5	5	G
	70	-	-	-	-	-	-	-	8	8	H
	80	-	-	-	-	-	-	-	10	10	I
	90	-	-	-	-	-	-	-	16	16	J
	100	-	-	-	-	-	-	-	24	24	K
	110	-	-	-	-	-	-	-	30	30	L
	120	-	-	-	-	-	-	-	36	36	M
	130	-	-	-	-	-	-	2	40	42	
	140	-	-	-	-	-	-	2	46	48	
	150	-	-	-	-	-	-	3	52	55	
	160	-	-	-	-	-	-	3	59	62	
	170	-	-	-	-	-	-	4	65	69	
	180	-	-	-	-	-	-	4	73	77	
	190	-	-	-	-	-	-	5	80	85	
	200	-	-	-	-	-	-	7	87	94	
	210	-	-	-	-	-	-	13	91	104	
	220	-	-	-	-	-	-	17	97	114	
	230	-	-	-	-	-	-	21	103	124	
240	-	-	-	-	-	-	24	109	133		

Figure 3A-1 (Sheet 4 of 15) CAF Air Diving Table 1 (Metres) – Standard Air Decompression Table

Depth (msw)	Bottom Time (min)	Stop Times (min) at Different Depths (msw)								Decom. Time (min)	Repet. Group
		24	21	18	15	12	9	6	3		
21	10	-	-	-	-	-	-	-	-	2	A
	15	-	-	-	-	-	-	-	-	2	B
	20	-	-	-	-	-	-	-	-	2	C
	25	-	-	-	-	-	-	-	-	2	D
	30	-	-	-	-	-	-	-	-	2	D
	35	-	-	-	-	-	-	-	-	2	E
	40	-	-	-	-	-	-	-	5	5	F
	50	-	-	-	-	-	-	-	10	10	G
	60	-	-	-	-	-	-	-	12	12	H
	65	-	-	-	-	-	-	2	12	14	I
	70	-	-	-	-	-	-	3	17	20	J
	80	-	-	-	-	-	-	4	25	29	K
	90	-	-	-	-	-	-	5	32	37	M
	100	-	-	-	-	-	-	6	39	45	N
	110	-	-	-	-	-	-	7	46	53	
	120	-	-	-	-	-	-	7	54	61	
	130	-	-	-	-	-	-	8	62	70	
	140	-	-	-	-	-	-	9	71	80	
	150	-	-	-	-	-	-	15	77	92	
	160	-	-	-	-	-	-	20	85	105	
170	-	-	-	-	-	-	25	93	118		
180	-	-	-	-	-	-	29	101	130		
190	-	-	-	-	-	-	34	109	143		
200	-	-	-	-	-	-	38	117	155		

Figure 3A-1 (Sheet 5 of 15) CAF Air Diving Table 1 (Metres) – Standard Air Decompression Table

Depth (msw)	Bottom Time (min)	Stop Times (min) at Different Depths (msw)								Decom. Time (min)	Repet. Group
		24	21	18	15	12	9	6	3		
24	10	-	-	-	-	-	-	-	-	2	A
	13	-	-	-	-	-	-	-	-	2	B
	15	-	-	-	-	-	-	-	-	2	C
	20	-	-	-	-	-	-	-	-	2	D
	25	-	-	-	-	-	-	-	-	2	E
	30	-	-	-	-	-	-	-	5	5	F
	35	-	-	-	-	-	-	-	9	9	G
	40	-	-	-	-	-	-	-	11	11	G
	45	-	-	-	-	-	-	3	10	13	H
	50	-	-	-	-	-	-	4	11	15	H
	55	-	-	-	-	-	-	5	15	20	I
	60	-	-	-	-	-	-	6	21	27	J
	65	-	-	-	-	-	-	7	25	32	J
	70	-	-	-	-	-	-	7	30	37	K
	75	-	-	-	-	-	-	8	34	42	L
	80	-	-	-	-	-	-	9	37	46	M
	85	-	-	-	-	-	-	9	42	51	
	90	-	-	-	-	-	-	10	46	56	
	95	-	-	-	-	-	-	11	50	61	
	100	-	-	-	-	-	-	11	55	66	
110	-	-	-	-	-	2	12	64	78		
120	-	-	-	-	-	3	18	72	93		
130	-	-	-	-	-	4	23	82	109		
140	-	-	-	-	-	4	28	93	125		
150	-	-	-	-	-	5	33	104	142		
160	-	-	-	-	-	5	39	114	158		

Figure 3A-1 (Sheet 6 of 15) CAF Air Diving Table 1 (Metres) – Standard Air Decompression Table

Depth (msw)	Bottom Time (min)	Stop Times (min) at Different Depths (msw)								Decom. Time (min)	Repet. Group
		24	21	18	15	12	9	6	3		
27	5	-	-	-	-	-	-	-	-	2	A
	10	-	-	-	-	-	-	-	-	2	B
	15	-	-	-	-	-	-	-	-	2	C
	20	-	-	-	-	-	-	-	-	2	D
	25	-	-	-	-	-	-	-	7	7	E
	30	-	-	-	-	-	-	2	9	11	F
	35	-	-	-	-	-	-	4	10	14	G
	40	-	-	-	-	-	-	6	10	16	H
	45	-	-	-	-	-	-	7	14	21	I
	50	-	-	-	-	-	-	8	20	28	J
	55	-	-	-	-	-	-	9	26	35	K
	60	-	-	-	-	-	2	8	31	41	L
	65	-	-	-	-	-	3	8	36	47	
	70	-	-	-	-	-	3	9	40	52	
	75	-	-	-	-	-	4	9	46	59	
	80	-	-	-	-	-	4	10	51	65	
	85	-	-	-	-	-	5	10	56	71	
	90	-	-	-	-	-	5	14	60	79	
95	-	-	-	-	-	6	17	64	87		
100	-	-	-	-	-	6	20	70	96		
110	-	-	-	-	-	7	26	82	115		
120	-	-	-	-	-	8	31	95	134		

Figure 3A-1 (Sheet 7 of 15) CAF Air Diving Table 1 (Metres) – Standard Air Decompression Table

Depth (msw)	Bottom Time (min)	Stop Times (min) at Different Depths (msw)								Decom. Time (min)	Repet. Group
		24	21	18	15	12	9	6	3		
30	5	-	-	-	-	-	-	-	-	2	A
	10	-	-	-	-	-	-	-	-	2	B
	12	-	-	-	-	-	-	-	-	2	C
	15	-	-	-	-	-	-	-	-	2	D
	20	-	-	-	-	-	-	-	8	8	E
	25	-	-	-	-	-	-	3	9	12	F
	30	-	-	-	-	-	-	5	10	15	G
	35	-	-	-	-	-	-	7	11	18	H
	40	-	-	-	-	-	-	9	16	25	I
	45	-	-	-	-	-	3	8	23	34	J
	50	-	-	-	-	-	4	8	29	41	K
	55	-	-	-	-	-	5	9	34	48	L
	60	-	-	-	-	-	6	9	40	55	
	65	-	-	-	-	-	6	10	46	62	
	70	-	-	-	-	-	7	10	52	69	
	75	-	-	-	-	-	8	14	56	78	
	80	-	-	-	-	-	8	18	61	87	
	85	-	-	-	-	-	9	21	67	97	
	90	-	-	-	-	2	8	24	75	109	
95	-	-	-	-	3	8	27	82	120		
100	-	-	-	-	3	8	31	90	132		
105	-	-	-	-	3	9	34	98	144		
110	-	-	-	-	4	8	38	106	156		

Figure 3A-1 (Sheet 8 of 15) CAF Air Diving Table 1 (Metres) – Standard Air Decompression Table

Depth (msw)	Bottom Time (min)	Stop Times (min) at Different Depths (msw)								Decom. Time (min)	Repet. Group
		24	21	18	15	12	9	6	3		
33	5	-	-	-	-	-	-	-	-	2	A
	10	-	-	-	-	-	-	-	-	2	B
	12	-	-	-	-	-	-	-	-	2	C
	15	-	-	-	-	-	-	-	5	5	D
	20	-	-	-	-	-	-	3	9	12	F
	25	-	-	-	-	-	-	6	10	16	G
	30	-	-	-	-	-	-	9	10	19	H
	35	-	-	-	-	-	3	8	16	27	I
	40	-	-	-	-	-	5	8	24	37	J
	45	-	-	-	-	-	6	9	31	46	K
	50	-	-	-	-	-	7	9	38	54	M
	55	-	-	-	-	-	8	10	44	62	N
	60	-	-	-	-	2	7	10	51	70	
	65	-	-	-	-	3	7	15	55	80	
	70	-	-	-	-	4	7	19	62	92	
	75	-	-	-	-	4	8	23	68	103	
	80	-	-	-	-	5	8	26	77	116	
	85	-	-	-	-	5	9	30	86	130	
	90	-	-	-	-	6	9	34	95	144	
	95	-	-	-	-	6	9	38	105	158	
100	-	-	-	-	7	9	42	114	172		
105	-	-	-	-	7	12	45	123	187		
110	-	-	-	-	8	15	48	130	201		

Figure 3A-1 (Sheet 9 of 15) CAF Air Diving Table 1 (Metres) – Standard Air Decompression Table

Depth (msw)	Bottom Time (min)	Stop Times (min) at Different Depths (msw)								Decom. Time (min)	Repet. Group
		24	21	18	15	12	9	6	3		
36	5	-	-	-	-	-	-	-	-	2	A
	8	-	-	-	-	-	-	-	-	2	B
	10	-	-	-	-	-	-	-	-	2	C
	15	-	-	-	-	-	-	-	10	10	E
	20	-	-	-	-	-	-	5	10	15	F
	25	-	-	-	-	-	-	9	10	19	G
	30	-	-	-	-	-	4	8	14	26	I
	35	-	-	-	-	-	6	8	24	38	J
	40	-	-	-	-	-	8	8	32	48	K
	45	-	-	-	-	3	6	10	38	57	M
	50	-	-	-	-	4	7	10	46	67	N
	55	-	-	-	-	5	7	13	53	78	
	60	-	-	-	-	6	7	18	59	90	
	65	-	-	-	-	6	8	22	66	102	
	70	-	-	-	-	7	8	27	75	117	
	75	-	-	-	-	8	8	31	86	133	
	80	-	-	-	2	6	9	35	97	149	
	85	-	-	-	3	6	10	40	107	166	
90	-	-	-	3	7	13	42	118	183		
95	-	-	-	4	6	16	46	128	200		
100	-	-	-	4	7	19	50	136	216		

Figure 3A-1 (Sheet 10 of 15) CAF Air Diving Table 1 (Metres) – Standard Air Decompression Table

Depth (msw)	Bottom Time (min)	Stop Times (min) at Different Depths (msw)								Decom. Time (min)	Repet. Group	
		24	21	18	15	12	9	6	3			
39	5	-	-	-	-	-	-	-	-	3	A	
	8	-	-	-	-	-	-	-	-	3	B	
	10	-	-	-	-	-	-	-	5	5	C	
	15	-	-	-	-	-	-	4	8	12	E	
	20	-	-	-	-	-	-	8	10	18	G	
	25	-	-	-	-	-	5	7	11	23	H	
	30	-	-	-	-	-	7	8	22	37	J	
	35	-	-	-	-	3	6	9	30	48	K	
	40	-	-	-	-	4	7	9	39	59	M	
	45	-	-	-	-	6	7	10	47	70	N	
		50	-	-	-	-	7	7	15	53	82	
		55	-	-	-	2	6	8	20	61	97	
		60	-	-	-	3	6	8	25	70	112	
		65	-	-	-	4	6	8	30	82	130	
		70	-	-	-	4	7	9	34	94	148	
		75	-	-	-	5	6	11	39	106	167	
	80	-	-	-	5	7	14	42	118	186		
	85	-	-	-	6	7	17	47	129	206		
	90	-	-	-	6	8	20	52	138	224		
42	5	-	-	-	-	-	-	-	-	3	A	
	7	-	-	-	-	-	-	-	-	3	B	
	10	-	-	-	-	-	-	-	7	7	D	
	15	-	-	-	-	-	-	6	9	15	F	
	20	-	-	-	-	-	4	7	10	21	G	
	25	-	-	-	-	-	7	8	17	32	I	
	30	-	-	-	-	4	6	8	28	46	K	
	35	-	-	-	-	5	7	9	37	58	L	
	40	-	-	-	-	7	7	10	46	70	N	
	45	-	-	-	3	5	8	16	53	85	O	
		50	-	-	-	4	6	8	21	62	101	
		55	-	-	-	5	6	8	27	73	119	
		60	-	-	-	6	6	9	32	86	139	
		65	-	-	-	6	7	10	37	99	159	
		70	-	-	-	7	7	14	40	114	182	
		75	-	-	3	5	7	18	45	126	204	
	80	-	-	3	6	7	21	51	137	225		
	85	-	-	4	5	8	25	57	146	245		
	90	-	-	4	6	8	28	65	152	263		

Figure 3A-1 (Sheet 11 of 15) CAF Air Diving Table 1 (Metres) – Standard Air Decompression Table

Depth (msw)	Bottom Time (min)	Stop Times (min) at Different Depths (msw)								Decom. Time (min)	Repet. Group
		24	21	18	15	12	9	6	3		
45	4	-	-	-	-	-	-	-	-	3	A
	7	-	-	-	-	-	-	-	-	3	B
	10	-	-	-	-	-	-	-	9	9	D
	15	-	-	-	-	-	-	8	9	17	F
	20	-	-	-	-	-	6	7	11	24	H
	25	-	-	-	-	4	5	8	23	40	J
	30	-	-	-	-	6	6	9	34	55	K
	35	-	-	-	3	5	7	10	44	69	M
	40	-	-	-	4	6	7	15	52	84	O
	45	-	-	-	5	6	8	21	61	101	
	50	-	-	-	6	7	8	27	73	121	
	55	-	-	3	5	6	9	33	88	144	
	60	-	-	3	5	7	12	38	103	168	
	65	-	-	4	5	8	16	42	119	194	
70	-	-	5	5	8	20	48	132	218		
75	-	-	5	6	8	24	55	142	240		
80	-	-	6	6	8	28	63	150	261		
48	6	-	-	-	-	-	-	-	-	3	B
	10	-	-	-	-	-	-	-	11	11	D
	15	-	-	-	-	-	4	6	10	20	G
	20	-	-	-	-	-	8	8	14	30	H
	25	-	-	-	-	6	6	8	29	49	K
	30	-	-	-	3	5	7	9	40	64	M
	35	-	-	-	5	5	8	13	49	80	N
	40	-	-	-	6	6	8	20	59	99	
	45	-	-	3	5	6	9	26	72	121	
	50	-	-	4	5	7	9	33	88	146	
	55	-	-	5	5	7	13	38	105	173	
	60	-	-	6	5	8	17	43	122	201	
	65	-	-	7	5	8	22	50	135	227	
70	-	3	4	6	8	26	58	146	251		

Figure 3A-1 (Sheet 12 of 15) CAF Air Diving Table 1 (Metres) – Standard Air Decompression Table

Depth (msw)	Bottom Time (min)	Stop Times (min) at Different Depths (msw)								Decom. Time (min)	Repet. Group
		24	21	18	15	12	9	6	3		
51	6	-	-	-	-	-	-	-	-	3	B
	10	-	-	-	-	-	-	5	8	13	D
	15	-	-	-	-	-	5	7	10	22	G
	20	-	-	-	-	5	5	8	20	38	I
	25	-	-	-	3	5	6	9	33	56	K
	30	-	-	-	5	5	7	10	46	73	M
	35	-	-	3	4	6	8	18	55	94	O
	40	-	-	4	5	6	8	26	68	117	
	45	-	-	5	5	7	9	32	85	143	
	50	-	-	6	6	7	13	37	105	174	
	55	-	3	4	6	7	18	44	122	204	
	60	-	4	4	6	8	23	51	137	233	
	65	-	5	4	6	9	27	61	148	260	
70	-	5	5	6	12	30	72	155	285		
54	5	-	-	-	-	-	-	-	-	3	B
	10	-	-	-	-	-	-	6	9	15	E
	15	-	-	-	-	-	7	7	11	25	H
	20	-	-	-	-	6	6	8	25	45	J
	25	-	-	-	5	5	7	9	39	65	M
	30	-	-	3	4	6	7	15	50	85	O
	35	-	-	5	4	6	8	23	62	108	
	40	-	-	6	5	7	9	30	80	137	
	45	-	4	4	5	7	13	36	101	170	
	50	-	4	5	5	8	18	42	121	203	
	55	-	5	5	6	8	23	51	137	235	
	60	-	6	5	6	9	28	61	149	264	

Figure 3A-1 (Sheet 13 of 15) CAF Air Diving Table 1 (Metres) – Standard Air Decompression Table

Depth (msw)	Bottom Time (min)	Stop Times (min) at Different Depths (msw)										Decom. Time (min)	
		30	27	24	21	18	15	12	9	6	3		
57	5	-	-	-	-	-	-	-	-	-	-	-	4
	10	-	-	-	-	-	-	-	-	-	8	9	17
	15	-	-	-	-	-	-	4	4	5	7	11	27
	20	-	-	-	-	-	4	4	6	9	29	52	52
	25	-	-	-	-	-	7	5	7	10	44	73	73
	30	-	-	-	-	5	4	6	8	19	55	97	97
	35	-	-	-	3	4	5	6	9	27	72	126	126
	40	-	-	-	4	4	5	7	11	35	93	159	159
	45	-	-	-	5	5	5	8	17	41	116	197	197
	50	-	-	3	3	5	6	8	22	50	135	232	232
55	-	-	4	3	5	7	9	27	61	149	265	265	
60	5	-	-	-	-	-	-	-	-	-	-	-	4
	10	-	-	-	-	-	-	-	-	10	9	19	19
	15	-	-	-	-	-	-	5	6	8	16	35	35
	20	-	-	-	-	-	5	5	6	10	33	59	59
	25	-	-	-	-	5	4	5	7	14	48	83	83
	30	-	-	-	3	4	4	6	9	23	62	111	111
	35	-	-	-	5	4	5	6	10	32	84	146	146
	40	-	-	-	6	4	6	7	15	38	109	185	185
	45	-	-	4	3	5	6	8	21	47	131	225	225
	50	-	-	5	4	4	7	9	27	58	147	261	261
63	5	-	-	-	-	-	-	-	-	-	5	5	5
	10	-	-	-	-	-	-	-	5	6	10	21	21
	15	-	-	-	-	-	-	7	6	8	20	41	41
	20	-	-	-	-	-	7	5	7	9	39	67	67
	25	-	-	-	-	6	4	6	8	17	52	93	93
	30	-	-	-	5	4	4	7	8	28	71	127	127
	35	-	-	3	3	4	6	7	12	35	97	167	167
	40	-	-	4	4	4	6	8	19	43	123	211	211
	45	-	-	5	4	5	6	9	25	54	142	250	250
	50	-	3	3	4	6	6	13	29	70	154	288	288

Figure 3A-1 (Sheet 14 of 15) CAF Air Diving Table 1 (Metres) – Standard Air Decompression Table

Depth (msw)	Bottom Time (min)	Stop Times (min) at Different Depths (msw)										Decom. Time (min)	
		30	27	24	21	18	15	12	9	6	3		
66	5	-	-	-	-	-	-	-	-	-	-	7	7
	10	-	-	-	-	-	-	-	7	6	10	23	
	15	-	-	-	-	-	4	5	5	9	24	47	
	20	-	-	-	-	5	4	5	7	10	43	74	
	25	-	-	-	4	4	4	6	8	21	58	105	
	30	-	-	3	3	4	5	7	9	32	81	144	
	35	-	-	5	3	4	6	7	16	39	110	190	
	40	-	3	3	4	4	7	8	23	49	135	236	
	45	-	4	3	4	5	7	11	28	65	151	278	
69	5	-	-	-	-	-	-	-	-	-	8	8	
	10	-	-	-	-	-	-	-	8	7	10	25	
	15	-	-	-	-	-	6	4	6	9	28	53	
	20	-	-	-	-	6	4	6	7	12	47	82	
	25	-	-	-	6	3	5	6	9	24	65	118	
	30	-	-	5	3	4	5	7	12	35	93	164	
	35	-	3	3	4	4	6	8	19	44	123	214	
	40	-	5	3	4	5	6	9	27	57	146	262	
72	5	-	-	-	-	-	-	-	-	-	9	9	
	10	-	-	-	-	-	-	4	5	7	11	27	
	15	-	-	-	-	-	7	5	6	9	32	59	
	20	-	-	-	4	4	4	5	8	16	50	91	
	25	-	-	4	3	4	5	6	9	28	73	132	
	30	-	-	6	3	5	5	8	15	37	106	185	
	35	-	5	3	4	4	6	9	23	49	135	238	
	40	3	3	3	4	6	6	13	28	67	153	286	

Figure 3A-1 (Sheet 15 of 15) CAF Air Diving Table 1 (Metres) – Standard Air Decompression Table

**CANADIAN ARMED FORCES AIR DIVING TABLE 1S (METRES)
SHORT STANDARD AIR DECOMPRESSION TABLE**

Depth (msw)	NO-DECOMPRESSION Bottom Time (min) / RG				DECOMPRESSION REQUIRED Bottom Time (min) / RG			
	6	30 A	150 E	360 I	720 M ∞			
60 B		180 F	420 J					
90 C		240 G	480 K					
120 D		300 H	600 L					
9	30 A	100 E	190 I	300 M	330 N	400	420	480
	45 B	120 F	210 J		360 O			
	60 C	150 G	240 K					
	90 D	180 H	270 L					
12	22 A	60 D	90 G	150 J	160 K	200	210	220
	30 B	70 E	120 H		170 L			
	40 C	80 F	130 I		180 M			
15	18 A	30 C	50 E	75 G	90 H	110 J	128 L	137 M
	25 B	40 D	60 F		100 I	120 K		
18	14 A	25 C	40 E	50 F	60 G	70 H	88 J	95 K
	20 B	30 D			80 I			

Decompression Time (min) at 3 msw

5	10	15	20
----------	-----------	-----------	-----------

Depth (msw)	NO-DECOMPRESSION Bottom Time (min) / RG				DECOMPRESSION REQUIRED Bottom Time (min) / RG			
	21	12 A	20 C	25 D	35 E	40 F	53 H	65 I
15 B								
24	10 A	15 C	20 D	25 E	30 F	37 G	50 H	54 I
	13 B							
27	9 A	12 B	15 C	20 D	24 E	28 F	35 G	44 I
30	7 A	10 B	12 C	15 D	18 D	22 F	30 G	37 H
33		6 A	10 B	12 C	15 D	18 E	24 G	31 H
36		6 A	8 B	10 C	12 D	15 E	19 F	25 G
39			5 A	8 B	10 C	13 D	17 F	21 G
42			5 A	7 B	9 C	12 D	14 F	18 G
45			4 A	7 B	8 C	10 D	13 E	16 G

Decompression Time (min) at

6 msw	-	-	5	10
3 msw	5	10	10	10

Y583FP0068-00

Figure 3A-2 CAF Air Diving Table 1S (Metres) – Short Standard Air Decompression Table

**CANADIAN ARMED FORCES AIR DIVING TABLE 4 (METRES)
REPETITIVE DIVING TABLE**

A. REPETITIVE FACTORS / SURFACE INTERVALS TABLE											
RG	Repetitive Factors (RF) for Surface Intervals (SI) (hr : min)										
	0:15 → 0:29	0:30 → 0:59	1:00 → 1:29	1:30 → 1:59	2:00 → 2:59	3:00 → 3:59	4:00 → 5:59	6:00 → 8:59	9:00 → 11:59	12:00 → 14:59	15:00 → 18:00
A	1.4	1.2	1.1	1.1	1.1	1.1	1.1	1.1	1.0	1.0	1.0
B	1.5	1.3	1.2	1.2	1.2	1.1	1.1	1.1	1.1	1.0	1.0
C	1.6	1.4	1.3	1.2	1.2	1.2	1.1	1.1	1.1	1.0	1.0
D	1.8	1.5	1.4	1.3	1.3	1.2	1.2	1.1	1.1	1.0	1.0
E	1.9	1.6	1.5	1.4	1.3	1.3	1.2	1.2	1.1	1.1	1.0
F	2.0	1.7	1.6	1.5	1.4	1.3	1.3	1.2	1.1	1.1	1.0
G	-	1.9	1.7	1.6	1.5	1.4	1.3	1.2	1.1	1.1	1.0
H	-	-	1.9	1.7	1.6	1.5	1.4	1.3	1.1	1.1	1.1
I	-	-	2.0	1.8	1.7	1.5	1.4	1.3	1.1	1.1	1.1
J	-	-	-	1.9	1.8	1.6	1.5	1.3	1.2	1.1	1.1
K	-	-	-	2.0	1.9	1.7	1.5	1.3	1.2	1.1	1.1
L	-	-	-	-	2.0	1.7	1.6	1.4	1.2	1.1	1.1
M	-	-	-	-	-	1.8	1.6	1.4	1.2	1.1	1.1
N	-	-	-	-	-	1.9	1.7	1.4	1.2	1.1	1.1
O	-	-	-	-	-	2.0	1.7	1.4	1.2	1.1	1.1

B. NO-DECOMPRESSION REPETITIVE DIVING TABLE										
Depth (msw)	Allowable No-D Limits (min) for Repetitive Factors (RF)									
	1.1	1.2	1.3	1.4	1.5	1.6	1.7	1.8	1.9	2.0
9	272	250	230	214	200	187	176	166	157	150
12	136	125	115	107	100	93	88	83	78	75
15	60	55	50	45	41	38	36	34	32	31
18	40	35	31	29	27	26	24	23	22	21
21	30	25	21	19	18	17	16	15	14	13
24	20	18	16	15	14	13	12	12	11	11
27	16	14	12	11	11	10	9	9	8	8
30	13	11	10	9	9	8	8	7	7	7
33	10	9	8	8	7	7	6	6	6	6
36	8	7	7	6	6	6	5	5	5	5
39	7	6	6	5	5	5	4	4	4	4
42	6	5	5	5	4	4	4	3	3	3
45	5	5	4	4	4	3	3	3	3	3

Y583FP0069-00

Figure 3A-3 CAF Air Diving Table 4 (Metres) – Repetitive Diving Table

**CANADIAN ARMED FORCES AIR DIVING TABLE 5 (METRES)
DEPTH CORRECTIONS FOR DIVING AT ALTITUDE TABLE**

Depth (metres)	Depth Correction at Altitude (METRES)								
	100 → 299	300 → 599	600 → 899	900 → 1199	1200 → 1499	1500 → 1799	1800 → 2099	2100 → 2399	2400 → 3000
9	+0	+3	+3	+3	+3	+3	+3	+6	+6
12	+0	+3	+3	+3	+3	+3	+6	+6	+6
15	+0	+3	+3	+3	+3	+6	+6	+6	+6
18	+0	+3	+3	+3	+6	+6	+6	+6	+9
21	+0	+3	+3	+3	+6	+6	+6	+9	+9
24	+0	+3	+3	+6	+6	+6	+9	+9	+12
27	+0	+3	+3	+6	+6	+6	+9	+9	+12
30	+0	+3	+3	+6	+6	+9	+9	+9	+12
33	+0	+3	+6	+6	+6	+9	+9	+12	+15
36	+0	+3	+6	+6	+6	+9	+9	+12	+15
39	+0	+3	+6	+6	+9	+9	+12	+12	+15
42	+0	+3	+6	+6	+9	+9	+12	+12	+18
45	+3	+3	+6	+6	+9	+9	+12	+15	+18
48	+3	+6	+6	+9	+9	+12	+12	+15	+18
51	+3	+6	+6	+9	+9	+12	+15	+15	+21
54	+3	+6	+6	+9	+9	+12	+15	+15	
57	+3	+6	+6	+9	+12	+12	+15		
60	+3	+6	+6	+9	+12	+12			
63	+3	+6	+6	+9					
66	+3	+6							
69	+3								

Sea Level Stop Depth (metres)	Actual Decompression Stop Depth at Altitude (METRES)								
	100 → 299	300 → 599	600 → 899	900 → 1199	1200 → 1499	1500 → 1799	1800 → 2099	2100 → 2399	2400 → 3000
3	3.0	3.0	3.0	3.0	3.0	2.5	2.5	2.5	2.5
6	6.0	6.0	6.0	5.5	5.5	5.0	5.0	5.0	4.5
9	9.0	9.0	8.5	8.5	8.0	7.5	7.5	7.0	7.0
12	12.0	12.0	11.5	11.0	10.5	10.0	10.0	9.5	9.0
15	15.0	14.5	14.0	13.5	13.0	12.5	12.0	12.0	11.5
18	18.0	17.5	17.0	16.5	16.0	15.0	14.5	14.0	13.5
21	21.0	20.5	20.0	19.0	18.5	17.5	17.0	16.5	16.0
24	24.0	23.5	22.5	21.5	21.0	20.0	19.5	19.0	18.0
27	27.0	26.0	25.5	24.5	23.5	22.5	22.0	21.0	20.0

Y583FP0070-00

Figure 3A-4 CAF Air Diving Table 5 (Metres) – Depth Corrections for Diving at Altitude Table

CHAPTER 4

DIVING EQUIPMENT

DESCRIPTION AND OPERATING PROCEDURES, COMPRESSED AIR BREATHING APPARATUS (CABA) AND ACCESSORIES

401. DESCRIPTION

1. The CAF diver using Compressed Air Breathing Apparatus (CABA) is normally an attended diver in self-contained mode. Canadian waters normally require the diver to be fully suited and to use the accessories described in this Chapter.
2. The standard CABA ensemble is comprised of the following:
 - a. Drysuit,
 - b. Fins,
 - c. Full facemask (FFM),
 - d. High-pressure air aluminum twin cylinders w/cylinder valve and “J”-valve manifold,
 - e. Regulators,
 - f. Buoyancy compensator (BC),
 - g. Digital depth gauge, and
 - h. Knives.
3. Weighted boots, the Light-Weight Surface-Supplied Diving Equipment (LWSSDE), wetsuits, search and rescue ensembles, and half-masks are available for specific operational requirements.
4. The CABA ensemble has been designed based on an assumption that all divers are subject to exposure to moderately contaminated waters in the normal course of CAF diving operations.
 - a. Generally and unless proven otherwise, all waters – including but not limited to harbours, rivers, inlets and landlocked waters – shall be considered MODERATELY CONTAMINATED. Even waters in large bays and the open sea may be contaminated.
 - b. Contaminated water diving is described and discussed further in [Chapter 5](#), which includes specific guidance on how to determine the degree of contamination.
5. The use of the CABA ensemble provides the capability for fully encapsulating the diver, affording adequate protection to a normal and healthy CAF member for diving operations.
6. There are a number of CABA variants permitted for operational requirements. The basic ensemble consists of:
 - a. CAF CABA drysuit with optional latex hood and liner (or neoprene hood), wrist seals, gloves, and CAF Diver Thermal Undergarments.
 - b. Buoyancy compensator (BC) with integral weights.
 - c. Double 2265-litre, (80 cu/ft) cylinders with cylinder valve and approved “J”-valve reserve manifold.

- d. A regulator with suit inflation, submersible pressure gauge (SPG), primary second-stage regulator with a full facemask (FFM) fitted, and a redundant second-stage regulator.
- e. Distress flare (for open water dives less than 30 msw).
- f. Lifeline harness.
- g. Working knife.
- h. Safety knife.
- i. Fins (or optional weighted boots).
- j. Digital depth gauge.
- k. Half mask.
- l. Ankle weights (optional).
- m. Strobe light (Mandatory for night diving).

7. In temperate waters and areas known to be uncontaminated, wetsuits of various thicknesses are authorised for use by selected teams.

8. The Light-Weight Surface-Supplied Diving Equipment is described at [Article 415](#).

9. The SAR Tech CABA ensemble offers a wide variety of options to the on-scene SAR Tech Diving Supervisor to effect rescue of distressed personnel while maintaining the safety of the divers. These are described in [Chapter 8](#).

10. Ice diving operations require specialised training and equipment configurations which are described in [Chapter 5](#).

11. This Chapter contains a general description of CABA equipment and accessories. Specific operating procedures are found in [Chapter 5](#). Details of function and second- and third-line maintenance are contained in the relevant CFTOs.

402. ENDURANCE

1. The endurance of CABA depends on the number of breaths a diver takes per minute and on the volume of each breath. These factors vary considerably with individual ability and degree of training, the amount of work being done (exertion), depth, and temperature of water. An increase in physical exertion and working in cold conditions result in greater consumption of air and decreases in endurance. Depth decreases endurance since the mass of air consumed increases with depth for a constant tidal lung volume.

- a. [Figure 4-1](#), *CABA Endurance Graph* and [Figure 4-2](#), *CABA Reserve with CABA Endurance Chart*, should be reviewed early in the dive planning process.
- b. [Figure 4-1](#) shows the endurance of a fully charged pair of aluminum cylinders, to a depth of 51 msw, for either light work or normal swimming.
- c. [Figure 4-2](#) shows the endurance of the 35 bar reserve.

2. During the planning phase of a dive, using any variant of the CABA ensemble, careful consideration must be given to:
 - a. The diver's ability to read the submersible pressure gauge in the expected U/W visibility, and
 - b. The planned duration of the dive, which must be reduced to account for the diver's increased air consumption. A planning factor of one-third of the expected endurance will normally provide a suitable safety margin. For example, an estimated endurance of 30 minutes would result in the diver being recalled to the surface at 20 minutes. Decompression stops must also be considered.

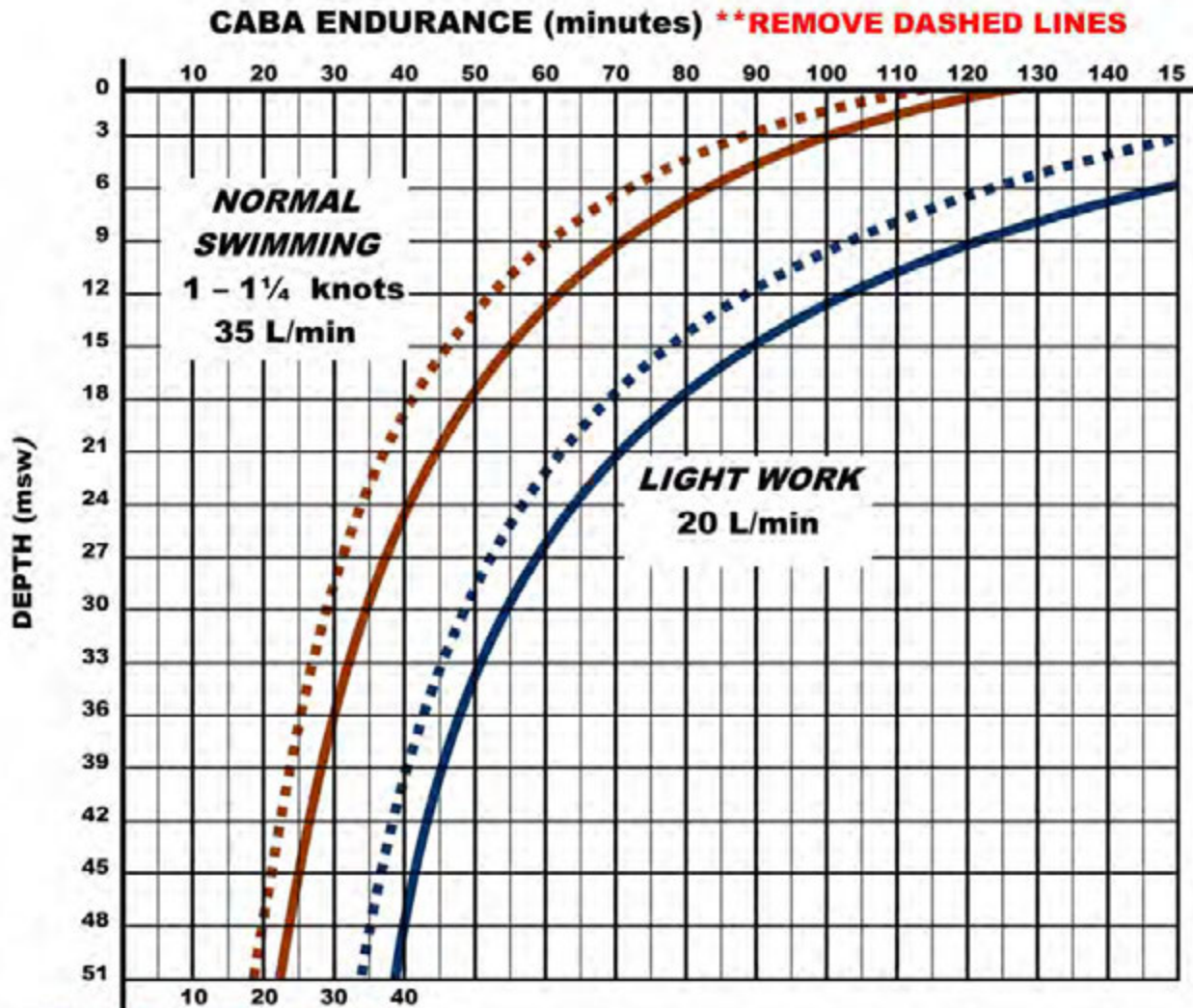

***HEY Get endurance figures

NOTES

1. Solid lines show endurance of double aluminum cylinders.
2. Endurance figures indicate the time at which the cylinders become empty. Dives must be planned to end well before this point.
3. When the SPG dial reads 35 bar (gauge) the dive is to be terminated.
4. Refer to Article 402 before using this graph.

Y583FP0071-00

Figure 4-1 CABA Endurance Graphic

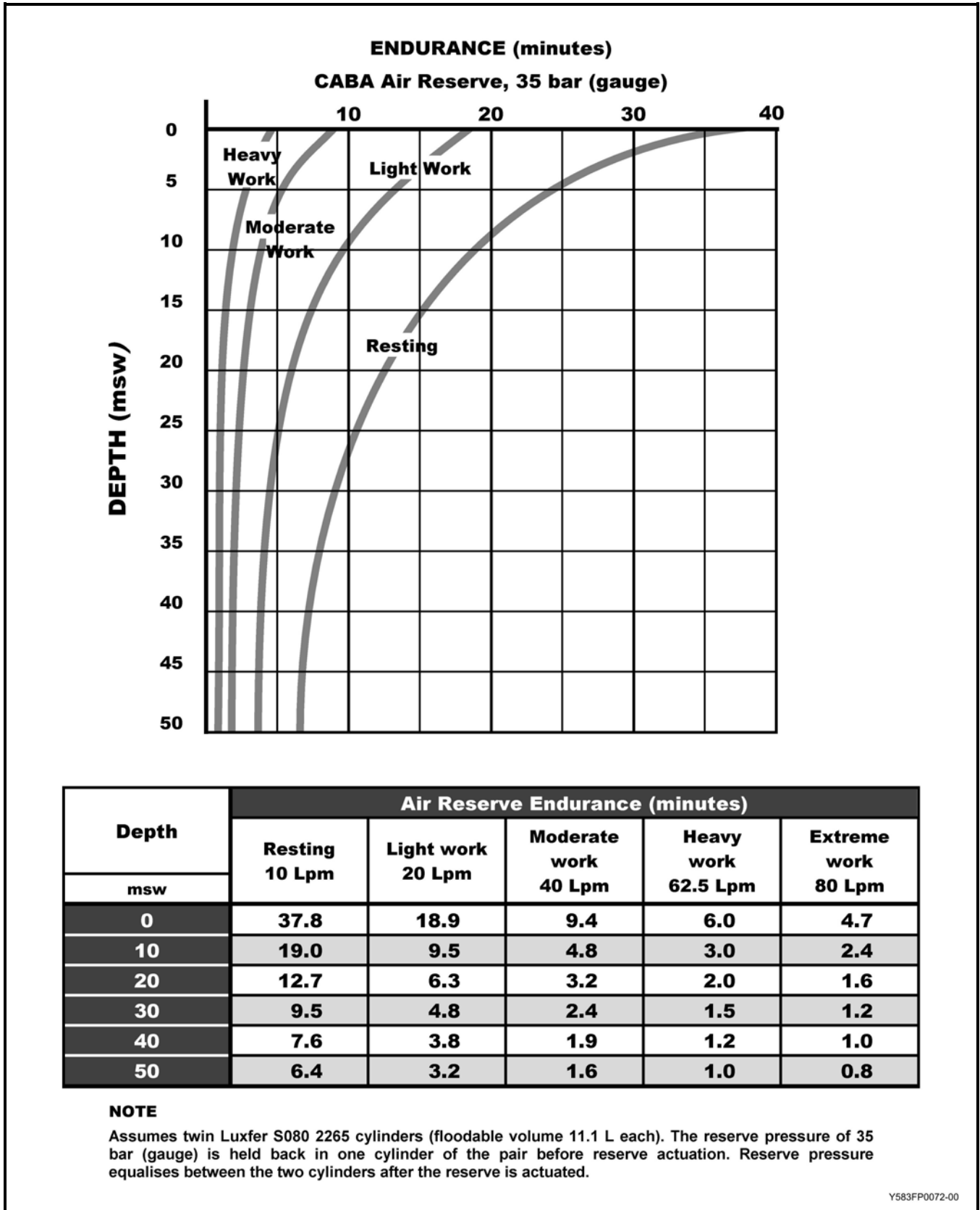

Figure 4-2 CABA Reserve with CABA Endurance Chart

403. DRYSUITS

1. The drysuit is used by divers in all elements of the CAF.
2. There are several types of diving drysuits in CAF service.
3. A drysuit provides a higher level of protection than a wetsuit from the surrounding environment (primarily cold and water contaminants).
4. It provides increased protection from the cold by maintaining an air envelope between the diver and the water thereby keeping the diver and insulating garments dry.
5. A diving drysuit provides a barrier between the diver and potentially hazardous material thereby increasing the chemical and biological protection.
6. The extra bulk and weight of the drysuit demands more effort for swimming and may also restricts movement at the joints.
 - a. Both neoprene and incompressible suits hold a considerable volume of air. This air provides thermal protection and buoyancy. Buoyancy control in a drysuit requires practice.
 - b. **Buoyancy Control in CAF Drysuits**
 - (1) Drysuits are fitted with an air inflation valve and an air exhaust valve for buoyancy control and to prevent suit squeeze or suit over-inflation. The inflation valve is located in the centre of the diver's chest for ease of access. However, this can increase the possibility that one of the other equipment straps rides up on the valve. Tension on the straps can lead to unintended actuation of the valve during the dive, followed by uncontrolled ascent. The diver may also become trapped if in a confined space, and may be unable to reach the exhaust valve. By attaching the suit inflation hose last, over the top of all other straps, the hose can be arranged so as to prevent the straps riding over the top of the valve. Supervisors shall verify this arrangement by sighting the inflation valve and straps during the pre-dive check.
 - (2) Air is supplied to the inflation valve via an IP hose from an intermediate pressure port on the first-stage regulator. The diver operates the inflation valve manually.
 - (3) An exhaust valve, located on the left forearm of the drysuit, is used to vent excess air from the drysuit and aid in controlling buoyancy. The diver may adjust the level of venting by rotating the valve face plate, either clockwise (closed) or counter-clockwise (open). The diver may also manually release air from the drysuit by pushing down on the valve face plate. Optimal performance will be achieved by raising the left arm as air in the suit will travel to the highest point. The valve will also open automatically to protect the suit from rupture due to over-inflation.

WARNING

The misuse of drysuit inflation or exhaust valves, the use of suit buoyancy to lift heavy objects or an inverted ascent may all result in an uncontrolled ascent with the possibility of serious injury or death.

404. INCOMPRESSIBLE DRYSUIT

1. The primary drysuit used by divers in all elements of the CAF is a self-entry, multi-laminate incompressible shell-type suit. Its use encapsulates the diver except for the hands and head. The head and hands may also be encapsulated via the additional features described below. CAF Incompressible Drysuit consists of the following:

- a. Heavy-duty UV resistant latex rubber wrist and neck seals.
- b. **Optional Detachable Latex Hood.** The latex hood is required when operating in known or suspected moderately contaminated waters.
- c. **Optional Detachable Gloves.** Either dry gloves (for use when conducting underwater welding/cutting) or if permitted, neoprene gloves. Neoprene gloves are permitted when operating in waters known to be uncontaminated.
- d. A self-entry pressure sealed slide fastener (zipper).
- e. Quick-disconnect LP swivel inflation valve.
- f. Suit exhaust valve.
- g. Optional dry shell sock with accompanying boot or integral moulded boot.

2. The suit offers little thermal protection unless worn with appropriate undergarments.

3. A cooling system such as a cooling vest may be required when diving in hot waters that require the use of a drysuit.

4. Suit squeeze is a significant factor when using an incompressible drysuit. This will be prevented with the wearing of undergarments. Experience has shown that the latex hood alone will likely result in ear squeezes. To minimize this squeeze, a diver wearing a latex hood must always wear some form of under-hood layer to prevent the latex sealing against the outer ear. Options such as a fleece toque, an open-cell foam hood liner, or the CAF-issue toque have all proven effective.

5. The multi-laminate drysuit shell material permits easy decontamination of the suit following exposure to salt water or moderately contaminated water. The suit will also afford limited single exposure to more heavily contaminated waters if accidentally exposed. Refer to [Chapter 5](#) for further detail.

6. The CAF drysuit may either be a made-to-measure suit or off the shelf version. It is to be replaced when required or when beyond economical repair (see [Figure 4-8](#)).

7. The Incompressible Drysuit must be fully donned when travelling in an open boat, otherwise a life jacket must be worn.

8. A diver candidate undergoing initial training will be issued a commercial off-the-shelf (COTS) pre-sized suit until successful completion of the training.

9. Care and Stowage of the Incompressible Drysuit

- a. Extra care must be taken with incompressible, vulcanized drysuits.
- b. Avoid contact with petroleum based products such as lotions (sunscreen) and petroleum based silicone lubricants as they will deteriorate the latex rubber of the neck and wrist seals.
- c. Rinse suit thoroughly with fresh water and when dry, apply talcum powder or cornstarch to seals.
- d. Clean the zipper and leave it open for ventilation. Lubricate the zipper teeth with beeswax. Do not use silicone spray or silicone grease. **Avoid excessive bending of the zipper.**
- e. These suits should be rolled rather than folded. Care must be taken to ensure the exhaust and inflation valves do not damage the suit material. Before the suit is packed, insert sheets of cardboard on each side of the inflation and exhaust valves to protect the suit material from chafing. Roll suit together starting at the boots. Roll the hood into the roll of the suit. Place sleeves along the roll. Store the suit in a storage bag or box.
- f. When wet, the suit must be dried inside and outside. This can be achieved by hanging the suit by the feet with a heavy-duty clothes hanger in an area with good air ventilation, out of direct sunlight with a temperature below 40°C.
- g. When dry, store by hanging from the shoulders in a cool, dark area away from fluorescent lights. Be careful not to crimp the neck seal.

NOTE

Improper storage will do more damage to a drysuit than extensive use.

405. PRE-DIVE AND POST-DIVE CHECKS, MAINTENANCE, REPAIR AND REPLACEMENT OF CAF INCOMPRESSIBLE DRYSUITS

1. 1st Line Maintenance



National Défense
Defence nationale

CAF INCOMPRESSIBLE DRYSUIT 1ST – LINE MAINTENANCE

PRE-DIVE CHECK

Step	Action	Remarks/Comments
1	Check for signs of damage during storage. NOTE: If the suit has been in extended storage, a leak test is strongly recommended prior to diving.	
2	Confirm the integrity of the latex neck and wrist seals. Look for rips, tears or cracking.	
3	Confirm the integrity of the latex hood (if required for MCW conditions).	
4	Lubricate latex seals (and hood if required) with cornstarch, talcum powder or other similar product. Do NOT use any petroleum-based products (including silicone) or any aerosol propellant product.	
5	Visually inspect the exhaust and inflation valves. Valve securing rings must be hand-tight.	
6	Rotate the exhaust valve faceplate fully clockwise and counter-clockwise to ensure the proper operation of valve.	
7	Extend the straps on the suspenders.	
8	Open zipper. Inspect teeth on zippers for kinks, breaks or missing teeth.	
9	Wax the inner sealing surface of the zipper with beeswax or paraffin wax.	
10	Close the zipper and wax its outer sealing surfaces.	
11	Open the zipper and place a small glob of the wax on the inside of the zipper teeth at the start end of the zipper (when closed). This ensures proper lubrication of the zipper when closing.	
12	Confirm the security of the suit penetrator blanking plates (if fitted).	

Y583FP0073-00

Figure 4-3 CAF Incompressible Drysuit 1st – Line Maintenance – Pre-dive Check



National Défense
Defence nationale

CAF INCOMPRESSIBLE DRYSUIT 1ST – LINE MAINTENANCE

POST-DIVE CHECK

Step	Action	Remarks/Comments
1	Check for signs of damage on exterior and interior of the suit.	
2	Rinse the suit in warm fresh water. Pay particular attention to the exhaust and inflation valves.	
3	Extend the straps on the suspenders.	
4	Hang the suit to dry in a cool, dark location by the feet if possible.	
5	When dry, roll the suit and store. Ensure that the zipper is open. Avoid kinking the zipper.	

Y583FP0074-00

Figure 4-4 CAF Incompressible Drysuit 1st – Line Maintenance – Post-dive Check



National Défense
Defence nationale

CAF INCOMPRESSIBLE DRYSUIT 1ST – LINE MAINTENANCE

REPAIRS

Step	Action	Remarks/Comments
1	If valves are not working properly, replace valves. Valves are only to be ordered on an “as required” basis. The suit shall be leak tested prior to diving.	Contact nearest FDU repair section for current replacement stock codes
2	Holes smaller than 2.5cm are to be repaired by the operator. The suit shall be leak tested prior to diving.	
3	Holes of any size on a seam shall be referred to Fleet Maintenance Facility (FMF) for repair.	
4	Torn or damaged wrist and neck seals are to be referred to FMF for repair.	
5	Damaged zippers are to be referred to FMF for repair.	
6	Damaged or replacement low-pressure hoses are to be replaced by the operator.	

Y583FP0075-00

Figure 4-5 CAF Incompressible Drysuit 1st – Line Maintenance – Repairs

2. **2nd – Line Maintenance.** 2nd – line maintenance is limited to the actions described in [Figure 4-6](#).

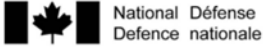

CAF INCOMPRESSIBLE DRYSUIT 2nd – LINE MAINTENANCE

Step	Action	Remarks/Comments
1	Advise customer if a suit is damaged beyond 1st – Line Maintenance.	
2	Advise customer is a suit should be condemned (withdrawn from service) and replaced.	
3	Technical advice on suit quality assurance (e.g. checking repair work if requested).	
4	Inspect drysuit (and accessories) involved in a diving incident/accident.	

Y583FP0076-00

Figure 4-6 CAF Incompressible Drysuit 2nd – Line Maintenance

3. **3rd – Line Maintenance.** All 3rd – line maintenance is conducted by a Fleet Maintenance Facility (FMF) or a factory-authorized representative. All 3rd – line maintenance will be accompanied by a work order issued by a FDU Supply Group. Upon completion of any repairs by 3rd – line maintenance, FMF will conduct a QA test. This may involve a leak test depending on the nature of the repairs involved. Upon completion of QA the suit will be returned to the originating dive team/unit where the diver is to verify that the repairs are satisfactory and IAW the procedures listed herein.



CAF INCOMPRESSIBLE DRYSUIT 3rd – LINE MAINTENANCE

Step	Action	Remarks/Comments
1	Repair holes greater than 2.5cm or located on a seam (beyond capability of 1st – line operator).	
2	Replace latex seals and hood.	
3	Replace zippers.	Zipper replacement performed by vendor (and not FMF) if FMF or FDU confirm that a replacement is warranted.
4	Repair or replace accessories (e.g. pocket matrix, boots, etc.) beyond the capability of 1st – line operator.	

Y583FP0077-00

Figure 4-7 CAF Incompressible Drysuit 3rd – Line Maintenance

4. **Suit Replacement Policy.** Suit replacement shall be on an “as required” basis. The unit Logistics Officer, in consultation with the Diving Officer, shall recommend replacement of the suit in accordance with the following guidelines.

NOTES

1. Once a suit has been recommended for write-off/replacement by second or third-line authority, the member’s clothing documents shall be amended to take the suit off charge, and a work order raised at the appropriate FDU to have a new suit made.
2. If the suit is still serviceable, it shall be turned over to the appropriate FDU (ensuring the mandatory CFSS accounting documentation is completed) for use by FDU training establishments.

		
CAF INCOMPRESSIBLE DRYSUIT REPLACEMENT POLICY		
Step	Action	Remarks/Comments
1	Suit no longer fits the diver due to significant change in weight/girth. As each case will present different considerations, the Diving Officer is to check the fit of the suit on the diver.	Suit must be well fitting, allowing full range of motion, but without excessive slack or loose material.
2	Suit is damaged beyond economical repair.	Degree of damage as assessed by a FDU or FMF.
3	Suit has been contaminated by matter that either cannot be removed or that poses such a health concern that further handling of the suit is unjustifiable (e.g. toxic chemical, infectious material/waste).	Advice from LCMM, D DIVE S, or FDU is available.

Y583FP0078-00

Figure 4-8 CAF Incompressible Drysuit Replacement Policy

406. NEOPRENE DRYSUIT

1. The CAF neoprene (compressible) drysuit is fabricated from 6-mm rubber with a 3-mm neck seal and 5-mm wrist seals. Although the suit is made of neoprene similar to a wetsuit it is made waterproof by a laminated layer glued to the interior. A neoprene hood and neoprene gloves are normally worn with this suit.

NOTE

This suit is being phased-out with the introduction into service of the CAF Incompressible Drysuit.

2. Transporting/Stowing a Neoprene Drysuit

- a. These suits should be rolled rather than folded. If the suit must be stowed or transported rolled in a dive bag or other container, care must be taken to ensure the exhaust and inflation valves do not damage the suit material. Before the suit is packed, insert sheets of cardboard on each side of the inflation and exhaust valves to protect the suit material from chafing.
- b. Clean the zipper and leave it open for ventilation. Lubricate the zipper teeth with beeswax. Do not use silicone spray or silicone grease.
- c. After unpacking, hang the suit as soon as possible as described in [paragraph 4](#).

NOTE

Improper storage will do more damage to a drysuit than extensive use.

3. Pre-dive Neoprene Drysuit Maintenance

- a. Open the zipper fully and make sure it is free of dirt or grit. Clean it with warm soapy water and a toothbrush if warranted.
- b. Lubricate the zipper teeth with beeswax. Do not use silicone spray or silicone grease.
- c. Conduct a functional check of the inflation valve and ensure the valve inlet fitting is pointing in the direction that will facilitate mating with the suit inflation hose.
- d. Conduct a function check of the exhaust valve in the fully opened and fully closed positions. Ensure that the exhaust valve grub screw/plastic pin is in place.
- e. Check the cuffs and neck seal for tears or rips. Apply cornstarch or talcum powder.

4. Post-dive Neoprene Drysuit Maintenance

- a. Clean the suit with fresh water (prior to doffing the suit if possible) after use in saltwater, chlorinated or contaminated water. Dirt, grit and stains should be removed with soap and warm water and then rinsed with fresh water.
- b. The drysuit inflation and exhaust valves must be rinsed after each dive, with particular attention being given to the exhaust valve.
- c. After 15 dives (or more often if diving where sand or grit may get in the exhaust valve), disassemble the exhaust valve and clean thoroughly with soap and warm water. Ensure the exhaust valve grub screw or plastic pin is replaced.
- d. The suit must be dried inside and outside. Normally, hanging by the feet from a heavy-duty clothes hanger will achieve this. Avoid direct sunlight and keep the temperature below 40°C with good air ventilation.
- e. When dry, store by hanging from the shoulders in a cool, dark area away from fluorescent lights. Be careful not to crimp the neck seal or zipper.

407. DRYSUIT THERMAL UNDERGARMENTS

1. The use of drysuit thermal undergarments provides the diver with passive thermal protection. Alternatives such as active heating and cooling systems are being developed for use with the new CAF Divers' Thermal Undergarments.
2. There are several versions of thermal undergarments available that provide varying level of thermal protection.
3. The use of a thin base layer of clothing is recommended to prevent suit squeeze and to wick moisture away from the diver's skin.

408. WETSUITS

1. Wetsuits are available for specialised operations. Most are made-to-measure but a wetsuit may also be provided as COTS item due to limited issue. Wetsuits are made of foam neoprene rubber and are designed to permit a small amount of water between the diver and suit. The fit should be snug but not so tight as to restrict movement or circulation or to cause discomfort.

2. The thickness of the suit governs its insulating and buoyancy properties and these properties will reduce as water depth increases. The increase in pressure as depth increases results in the cells in the neoprene being compressed, resulting in partial loss of thermal efficiency and buoyancy. Divers unaccustomed to deeper depths must be attentive to the significant buoyancy changes in order to maintain control of descent and ascent.

3. The common sizes used by CAF members are:
- a. 7-mm (standard wetsuits issued to authorised personnel),
 - b. 3-mm diveskins for specific operational and training requirements, and
 - c. 0.5-mm for diving teams conducting operations and training in tropical/temperate waters.

409. WETSUIT MAINTENANCE AND STOWAGE

1. Proper maintenance and storage increases the normal-use life expectancy of a wetsuit.
2. Repairs to a wetsuit can be done easily and quickly with liquid adhesives recommended by the manufacturer. A suit that requires repair must be completely dry and salt-free in the area where the adhesive is to be applied. Normally, 15 minutes is sufficient time for the adhesive to bond. However, full curing IAW the manufacturer's instructions should be followed whenever possible.

3. Proper Stowage of a Wetsuit

- a. Ideally, the suit should be rinsed with fresh water and suspended on wooden hangers in a well-ventilated compartment.
- b. For stowage in confined spaces, the suit should be rolled, avoiding folds.
- c. Heavy weights will break down the unicellular structure of the neoprene and should never be placed on top of the wetsuit.
- d. The life of the suit will be shortened if it is dried with excessive heat or if it is stored in very warm areas.
- e. Do not store wetsuits in areas where electric motors are running. The ozone gas generated by electric motors is harmful to the molecular structure of the wetsuit material.

410. BUOYANCY COMPENSATOR, BLACK DIAMOND® CANADIAN MILITARY VERSION (BDCMVBC)

1. The BDCMVBC is a buoyancy-compensating device used by all divers in the CAF. It does not meet civil Personal Flotation Device (PFD) – lifejacket – requirements and is not intended for use as such. It is provided in two colour styles: either all black (for Combat Divers) or with distinctive red reflective bands (for all other divers). It contains no internal bladder.

- a. The buoyancy compensator (BC) has the following features:
 - (1) An integral harness that permits use of either single or double cylinders.
 - (2) A releasable weight system.
 - (3) Adjustable waist strap/cummerbund mounting two releasable weight pouches.
 - (4) Two non-releasable weight pouches mounted on the harness back.
 - (5) Two shoulder releases with swivel quick-release.
 - (6) Quick-adjust shoulder strap rings.

- (7) Adjustable chest strap.
- (8) Back comfort pad.
- (9) Shoulder and waist attachment rings (refer to *BC Precautions and Warnings*, [paragraph 3](#)).
- (10) Integral front and side pockets.
- (11) Crotch strap (optional).
- (12) Strobe light holster on right shoulder.
- (13) SPG retainer clip.
- (14) Four D-rings.
- (15) Carrying handle (refer to *BC Precautions and Warnings*, [paragraph 3](#)).
- (16) Low-pressure (LP) inflator with dual exhaust valves.
- (17) Two overpressure relief valves.
- (18) Up to 23 kg (50 pounds) positive buoyancy.

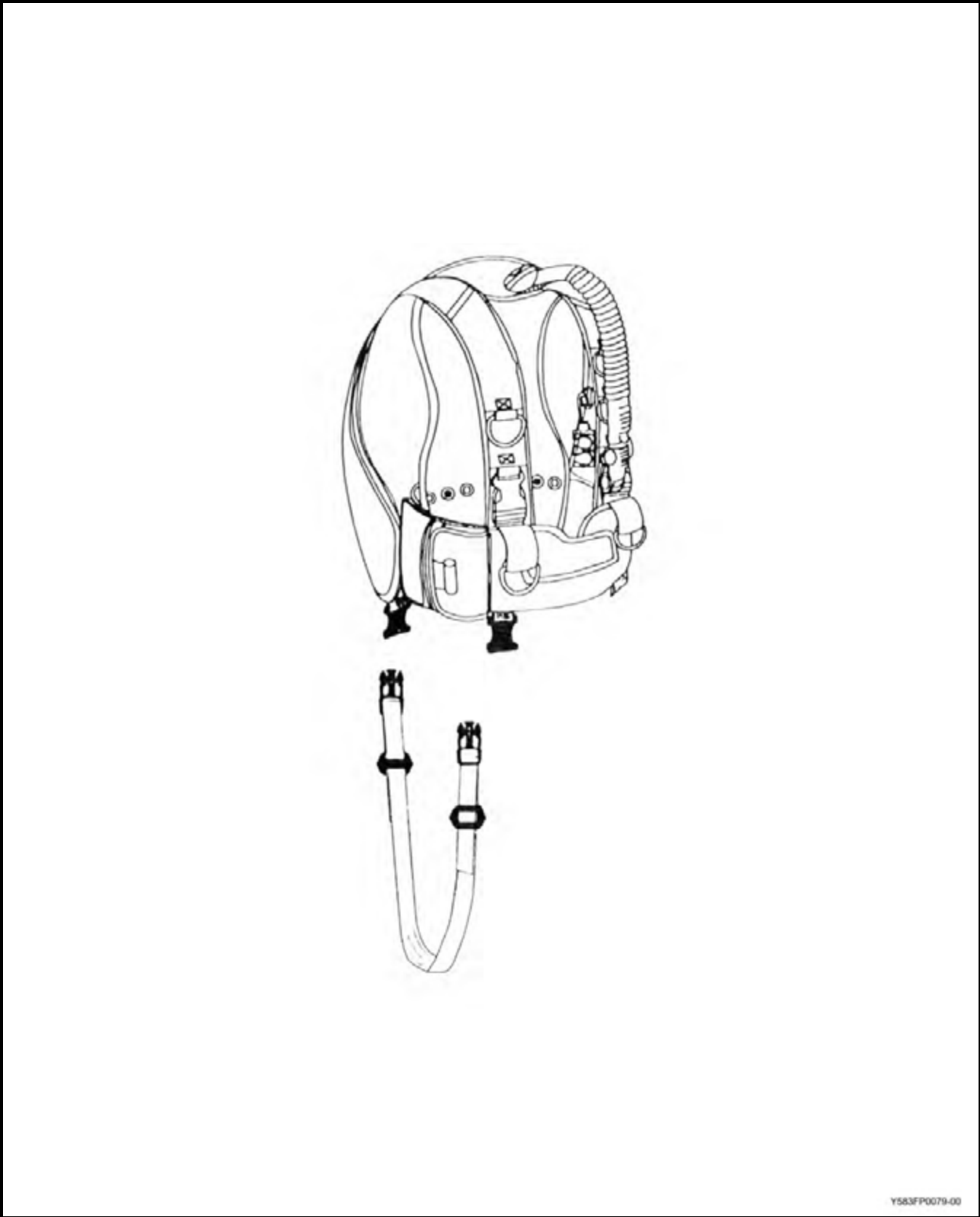

Y583FP0079-00

Figure 4-9 BDCMVBC

2. BC Maintenance

- a. Fully detailed operator's maintenance instructions are contained in C-87-356-000/ML-001.
- b. Complete overhaul, planned and corrective maintenance procedures for use by qualified Clearance Diver Maintainers (MOS ID 00342) are contained in C-87-356-000/MS-001.

3. BC Precautions and Warnings

- a. Before every dive, perform a complete pre-dive inspection according to the procedures in the next section to ensure all components are functioning properly and no signs of damage or leaks are present. If the BC is not functioning properly or is damaged remove it from service until it can be repaired.
- b. The BC is NOT a lift bag. Divers are cautioned NOT to use its buoyancy to carry heavy objects to the surface. Dropping a heavy object could lead to a rapid uncontrolled ascent. This could result in serious injury or death due to embolism or decompression sickness.
- c. Failure of the BC could also lead to a rapid uncontrolled ascent or descent. This could result in serious injury or death due to embolism or decompression sickness.
 - (1) In the event of an uncontrolled, rapid ascent: IMMEDIATELY begin venting air from the BC. Continue venting air to slow the ascent rate if neutral buoyancy cannot be re-established.
 - (2) In an emergency such as an out-of-air situation or uncontrolled descent IMMEDIATELY remove and jettison weights. Do NOT depend solely on the BC's power inflator for lift.
- d. Personnel not trained or authorised must not attempt to disassemble, repair or lubricate this equipment.
- e. Lifelines shall NOT be attached to the BC. The buddy line attachment loop may be secured to the waist BC D rings only.
- f. The carrying handle has limited strength and is NOT intended to lift divers out of the water. Do NOT use the carrying handle as the sole carrying point when CABA cylinders are attached.
- g. This BC has the potential to position a stricken diver face down on the surface.

4. BC Pre-dive Inspection

- a. Before each dive, perform a complete pre-dive inspection IAW C-87-356-000/ML-001. Connect the power inflator to a diving air source, via the LP quick-disconnect hose. Depress and release the inflator button intermittently to ensure the airflow is unobstructed, and that the airflow stops completely when the button is released. Manually operate all overpressure relief valves to ensure they are functioning properly.
- b. Check the functions of the oral inflator button, dual exhaust valve and overpressure relief/manual dump valve to ensure a rapid and unobstructed exhaust from each valve. Inflate the BC once again.
- c. Listen closely for any leakage. If any leakage is heard, or if the bladder begins to deflate within 5 – 10 minutes, tag and quarantine the BC, contact nearest Fleet Diving Unit repair facility.
- d. Ensure tank straps are in serviceable condition and buckles are not broken or cracked.
- e. Inspect weight pouches for damage and ensure Hook and Loop (velcro) is clear of debris and in serviceable condition.

5. BC Post-dive Inspection and Care

- a. The following preventative maintenance must be performed to extend the life of the BC:
 - (1) Avoid prolonged exposure to direct sunlight and extreme heat. Extreme heat may damage the welded seams of the BC's bladder.
 - (2) Avoid repeated or prolonged use in heavily chlorinated water. Such use can cause the BC fabric to discolour and decay prematurely.
 - (3) Do not allow the BC to chafe against any sharp objects or rough surfaces that could abrade or puncture the bladder.
 - (4) Do not place or drop heavy objects on the BC (e.g. block weights).
 - (5) Avoid any contact with oil, gasoline, aerosols or chemical solvents.
 - (6) To preserve the life of the bladder, thoroughly rinse it inside and out with fresh water after every day of use, using the following procedure:
 - (a) Before rinsing, ensure the power inflator is pressurized with air. This will prevent debris and contaminants from entering the valve mechanism if the inflator button is accidentally depressed.
 - (b) Using a fresh water hose, direct water through the washout port or the oral inflator to clean the interior of the bladder. Then thoroughly rinse the exterior of the BC.
 - (c) Completely drain the bladder of water, through the oral inflator and through the overpressure relief valves, being careful to avoid operating the power inflator button.
 - (d) Remove drain cap and allow the BC to dry. ****Info DMSS

NOTE

Failure to thoroughly rinse the interior of the bladder will cause salt build-up. This will cause damage to the power inflator, exhaust valves and over pressure relief valves.



Do not store the BC in an enclosed space where temperatures may fall below -18° C or rise above 49° C.

- (7) Once dry, partially inflate BC and store in a clean, dry area away from direct sunlight.

411. INTEGRAL DIVING WEIGHTS

- 1. The BDCMVBC enables sufficient weight to be worn by the diver so that separate weights are normally not required (except in specific operational modes, e.g. LWSSDE plodding operations).
- 2. It is very important for the diver to be thoroughly familiar with the correct method for installing and releasing weights before diving the equipment.
- 3. Divers will normally remove the BC weight pouches before exiting the water in order to reduce strain on both the diver and the equipment.

4. Additional soft ankle weights may be worn as required by the diver. They should be easily removable, normally by means of a Fastex® connection.

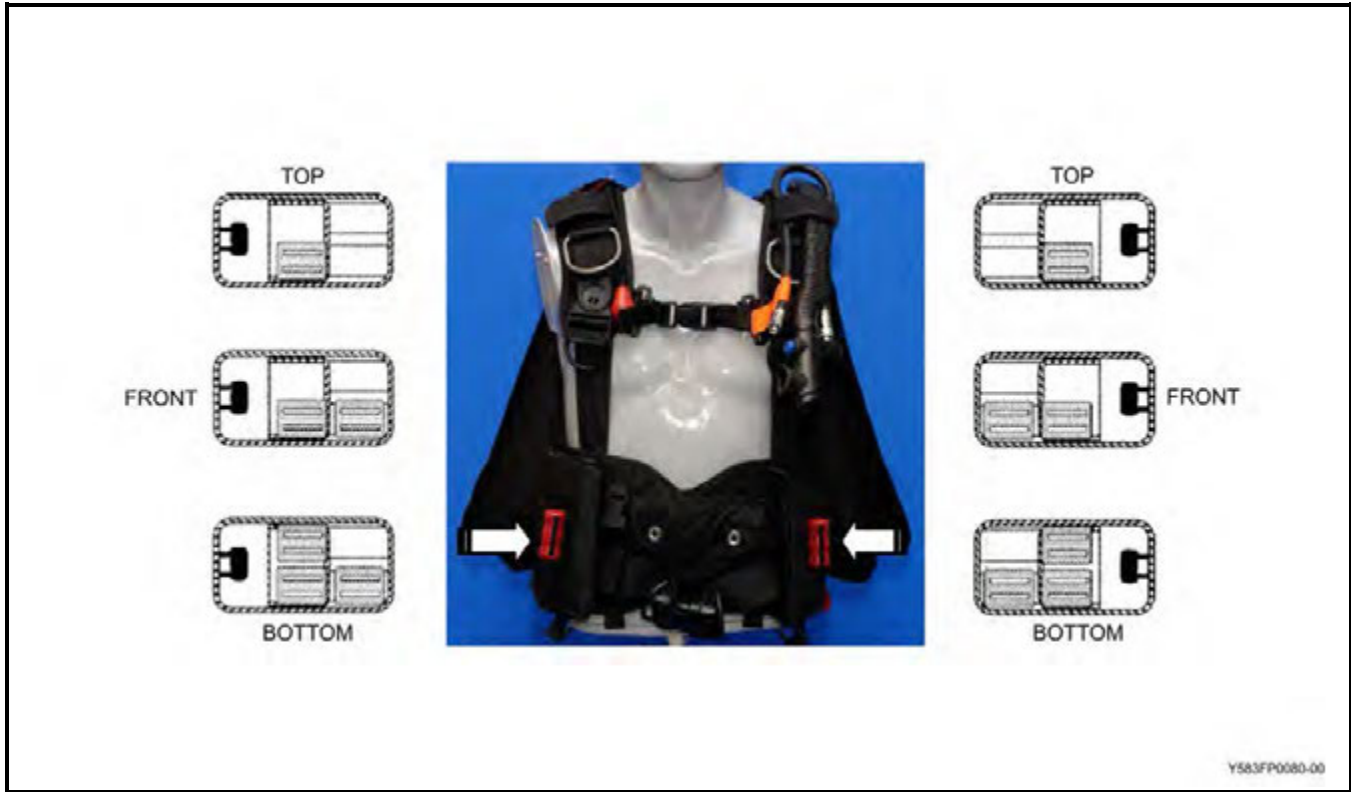

Figure 4-10 Loading Options, Integral BDCMVBC Weight Pouches

412. HP AIR CYLINDERS

1. CABA cylinders are rated for a minimum working pressure of 205 bar (gauge).
2. Cylinders used in CAF operations are normally made of aluminum.
3. The difference in buoyancy between fully charged and empty cylinders is significant enough to affect the diver. For example, a set of double 2265-litre aluminum cylinders lose approximately 4 kilograms in weight from fully charged to empty and will gain considerable buoyancy as the air is consumed.
4. Cylinders are normally fitted with one of the following cylinder valves:
 - a. “J”-valve (provides a positive reserve breathing supply of 35 bar) or,
 - b. “K”-valve (no reserve breathing supply). Cylinders fitted with a “K”-valve do NOT have a reserve of air and are only used in specific operations.
 - (1) CABA with this valve should only be used when fitted with a submersible pressure gauge (SPG). When the SPG needle reads 35 bar, the dive is to be terminated. Refer to [Article 402](#) for additional air endurance precautions.
5. The CAF currently uses the following CABA cylinders:
 - a. **368-litre (13 cu ft) Cylinder Fitted with a “K”-valve.** Used primarily in SAR operations as Survivor Auxiliary Air Cylinders (SAAC).

b. **850-litre (30 cu ft) Cylinders Fitted with a “K”-valve.** Used in specific applications. (e.g. SAR missions or LWSSDE).

c. **2265-litre (80 cu ft) Cylinders Fitted with a “J”-valve**

- (1) The most common cylinder in CAF use.
- (2) The 2265-litre cylinders may be used in single or double configuration. Most CAF divers will use twin 2265-litre cylinders as this provides sufficient endurance for many common tasks. The double cylinder assembly is held together by steel bands that support the “J” pull rod. A high-pressure manifold is used to join the two cylinders and support the air regulator.
- (3) The “J”-valve is a safety device that maintains a reserve breathing supply of 35 bar by means of a spring-loaded restricting device.
 - (a) The reserve “J”-valve is to be in the “UP” position prior to diving.
 - (b) Divers and buddies are to ensure that the reserve “J”-valve remains UP throughout the dive.



If the diver is required to actuate the reserve due to reduced air supply the dive shall be terminated.

d. **2832-litre (100 cu ft) Cylinders Fitted with a “J”-valve.** Used by SAR Techs, Clearance Divers and Submariners.

CHECKING CABA HP CYLINDER PRESSURE

Prior to any diving using CABA the air cylinder pressure must be determined by the diver. The following procedure shall be used:

- 1) Inspect cylinder valve "O" ring.
- 2) Secure the test gauge on cylinder filler valve.
- 3) Ensure the bleeder valve on the test gauge is CLOSED.
- 4) Ensure the cylinder reserve valve is DOWN.
- 5) Slowly OPEN the cylinder valve.
- 6) NOTE THE PRESSURE. _____ bar
- 7) Place the cylinder reserve valve in the UP position.
- 8) CLOSE the cylinder filler valve.
- 9) Slowly OPEN the test gauge bleeder valve. After the pressure is released remove the test gauge.
- 10) Attach the regulator, slowly OPEN the cylinder valve and check the regulator for function.
- 11) Compare SPG and cylinder gauge pressures, which must be within ± 15 bar (gauge).

RECHARGING CABA HP CYLINDERS

If the air cylinders require recharging, the following procedure shall be used:

- 1) Ensure that Hydro and Visual inspections are in date.
- 2) Examine cylinders for damage.
- 3) Ensure the cylinder reserve valve is down.
- 4) Connect the supply yoke to the cylinder valve.
- 5) Ensure the yoke bleeder valve is closed.
- 6) Ensure pressure on the charging line.
- 7) Slowly OPEN the cylinder valve.
- 8) Slowly OPEN the supply valve and fill the air cylinders to their working pressure.
- 9) CLOSE the cylinder valve and the air supply valve.
- 10) Bleed off the pressure in the supply yoke bleeder valve before removing the yoke.
- 11) Place the reserve valve in the UP position.

Figure 4-11 CABA Cylinder Recharging Procedure

413. AIR REGULATOR

1. The diving regulator is a two-stage demand mechanism that reduces the high-pressure air in the supply cylinder to breathable, ambient pressure at the diver's mouthpiece. It automatically compensates for changes in cylinder pressure and diving depth. To safely and effectively operate the regulator, divers must be thoroughly familiar with its operation.
 - a. The first-stage regulator, fitted to the cylinder valve, reduces the air from the supply cylinder to an intermediate pressure of approximately 9.3 bar.
 - b. The second-stage regulator, provides air to the diver by reducing the intermediate pressure to a breathable, ambient pressure.
2. The first stage regulator will be fitted with:
 - a. Two intermediate pressure hoses of different lengths, which supply air to a primary and a redundant second-stage regulator.
 - b. The primary second-stage is normally fitted to a FFM. For mission specific operations, a conversion to AGA half mask may be performed at the discretion of the on-site diving supervisor (refer to [Article 415](#) for procedure).
 - c. The redundant second-stage regulator is intended for use as an emergency air source for a buddy diver.
 - d. Regardless of the CABA variant being used, the redundant second-stage regulator shall be secured within the diver's safety triangle (refer to [Article 422](#)). The methods of securing may include a rubber band secured to a D ring, or an installed special purpose clip. This will prevent the regulator from accumulating debris from the seabed, which could render it non-functional. It also ensures the divers can locate it quickly during an emergency.
3. Each diver's first stage regulator is also fitted with:
 - a. A high-pressure hose fitted with a submersible pressure gauge (SPG).
 - b. A low-pressure inflation hose for the BC.
 - c. A low-pressure drysuit inflation hose.
4. Regulators used in SAR operations and ice diving require specific changes to this configuration and are described elsewhere in this publication.
5. For regulator post-dive *cleaning and storage*, see [Figure 4-12](#).

**REGULATOR PRE-DIVE
PROCEDURE**

There are two methods of routinely cleaning regulators after each dive:

PRESSURIZED METHOD

1. Inspect for damage
2. Check overall condition
3. Moore to come from Rickey

**REGULATOR POST-DIVE
CLEANING AND STORAGE PROCEDURE**

NOTE

Soaking regulator parts in warm water will remove more salt and mineral deposits than will conventional rinsing.

There are two methods of routinely cleaning regulators after each dive:

PRESSURIZED METHOD

1. Connect regulator to pressurized air source and slowly open supply valve.
2. Thoroughly soak or rinse the regulator/FFM with fresh, warm (not over 50°C) tap water to remove salt and mineral deposits. Ensure water is directed in to the second-stage regulators. Depress the purge button for a few seconds while water is in the second-stage.
3. To remove excess water after soaking is complete, purge the second-stage a few more times and gently shake the second stage to remove excess water.
4. CLOSE the air supply valve.
5. Disconnect the first-stage from the pressurize air source.
6. Dry the dust cap before putting it over the inlet port of the first-stage.
7. Air dry the regulator away from direct sunlight.

NON-PRESSURIZED METHOD

1. Can be performed if no air source is available.
2. Soak or rinse the entire first-stage in warm, fresh tap water with the dust cap in place.
3. Thoroughly soak or rinse the second-stage regulator/FFM. DO NOT PUSH IN THE PURGE BUTTON while soaking the second-stage as this allows water to enter the hose and first-stage, causing corrosion.

Figure 4-12 (Sheet 1 of 2) Regulator Post-dive Cleaning and Storage

4. Gently shake the second stage to remove excess water after soaking.
5. Air dry the regulator away from direct sunlight.

REGULATOR STORAGE



NEVER store the regulator while still connected to a CABA cylinder.



DO NOT use any type of solvent to clean any part of the regulator.



DO NOT carry the CABA cylinder by the regulator or hoses. Such abuse will eventually damage the regulator or the cylinder valve.



DO NOT loosen or remove the secondary diaphragm retaining ring or the secondary diaphragm from the first-stage. This will result in loss of silicone fluid, making the regulator unfit for cold water use.

After air drying, store the regulator as follows:

1. Store in a clean equipment box or as an alternative, store or hang in a dry, secure area.
2. If the regulator is to be stored for a long period of time it is good practice to wipe the rubber parts with a light application of silicone grease using an impregnated cloth.

Figure 4-12 (Sheet 2 of 2) Regulator Post-dive Cleaning and Storage

414. AGA MK II FULL FACEMASK (FFM)/REGULATOR

1. AGA “Divator” MK II FFM

- a. The Interspiro AGA “Divator” MK II full facemask is made of soft rubber/silicon with a visor of high impact polycarbonate plastic.
- b. The mask's flat clear faceplate is matt-finished to reduce optical distortion.
- c. The mask incorporates a demand second-stage regulator and can be fitted with a microphone/earphone assembly for hardwire or through-water communications.
- d. The mask is secured to the diver by a five-strap rubber “spider” harness that is fastened and tightened with stainless steel buckles. The wide, double-flanged sealing edge of the mask is held to the contours of the face by the harness creating an effective seal.
- e. The regulator utilizes a balanced design resulting in low breathing resistance.
- f. The mask is fitted with an inner oral-nasal mask and an adjustable nose block push pad.
- g. The regulator is attached to the full facemask using a bayonet coupling. The lightweight material and low-profile design reduce hydrostatic drag and conforms to the shape within the mask. There are no protruding parts to be fouled or to unbalance the mask.
- h. The inner oral-nasal mask incorporates one-way valves that minimize dead air space. Additionally, separate one-way valves in the inhalation and exhalation ports do not allow the supply and exhaust gases to be mixed.
- i. During inhalation, gas is delivered from the AGA regulator through the mask de-fogging ports, across the visor and into the oral-nasal mask. Exhaled gas is expelled to the ambient water from the oral-nasal mask through the regulator exhalation valve.



Figure 4-13 AGA Divator MK II FFM

2. Changing From FFM to Half Mask (Regulator) Configuration

- a. To change the AGA MK 2 from FFM to Half Mask configuration, the following procedures are to be followed:
 - (1) Remove the blanking plate cover assembly (1) from FFM;
 - (2) Remove the second stage regulator from FFM;
 - (3) Remove O ring (2) from second stage valve housing (3);
 - (4) Install mouthpiece (4);
 - (5) Using a flathead screwdriver, secure mouthpiece with band clamp (5); and
 - (6) Perform a leak check.
- b. To reinstall the AGA FFM, remove the mouth piece and re-install the O ring to the second stage valve housing. Secure the second stage to the AGA FFM and perform leak check.



Figure 4-14 Changing From FFM to Half Mask (Regulator) Configuration

3. AGA Redundant Second-stage Regulator

- a. The AGA full face mask regulator and redundant second stage regulator are similar in appearance and are both demand regulators. The significant difference is that the redundant second stage regulator has a locking lever and mouthpiece.
- b. The locking lever is fitted in order to reduce the possibility of a free flow by physically holding the inlet valve shut until the diver takes a breath or pushes the purge button.
- c. Both divers and supervisors shall perform a function test during pre-dive checks and ensure that the locking lever is against the valve housing, in the locked position prior to diving.

4. Redundant Second Stage Monthly Non-return Valve (NRV) Leak Check

- a. This test only applies to the Redundant Second Stage (RSS). The NRV in the FFM regulator is fully encapsulated and does not require this testing.
- b. IAW DTI 2009/03 the NRV shall be inspected and leak tested monthly to ensure the integrity of the red NRV. This test may be performed with mounthpiece attached or removed.
- c. Procedure for NRV leak check:
 - (1) Fill NRV free space with water (approx 1 tsp).
 - (2) Check that no water leaks into the second stage (the water level must not drop).
 - (3) Empty the water and blow the valve dry by pressing the purge button.
 - (4) If the NRV fails this test, contact the nearest FDU repair facility.

5. **First-line Operator Maintenance, AGA MK II FFM**

a. **Pre-Dive Checks, AGA MK II FFM**

- (1) Visually inspect the mask body to ensure all silicon, rubber, metal, and moulded plastic components are in good condition and show no signs of damage, rip, tear, and cracking.
- (2) Inspect the head harness (natural rubber) and adjusting straps to ensure serviceability and straps are fully extended.
- (3) Check that all non-return valve discs in the inner mask are flat and secured.
- (4) Ensure that the pressure equalizing pad is in place and adjusted.
- (5) Check that the locking nut on the breathing valve is securely tightened.
- (6) Check that the locking ring on the breathing valve is securely tightened and not cross threaded.
- (7) Check all hoses for damage, cracks, discoloration, and changes in hardness.

NOTE

Check Nos. 5, 6, and 7 are to be conducted on both the AGA full facemask second stage regulator and Redundant second stage regulator.

- (8) Ensure the locking lever on the breathing valve of the Redundant second stage regulator is serviceable and positioned towards the valve housing.
- (9) Remove dust cap of primary first stage regulator, connect to a pressurized dive cylinder, and slowly open cylinder valve to pressurize the system.
- (10) Air should not leak through primary first stage or through the second stage regulators. Immerse mask and redundant second stage regulator in water to check for leaks. During cold weather precaution, check for leaks with a leak detector compound (soapy water or Snoop).

NOTE

If you notice leakage from the first or second stage, shut the cylinder valve and tag the AGA face mask as unserviceable. Return to appropriate FDU Repair Facility for investigation and repair.

- (11) Press the purge button to determine if there is sufficient airflow going through the mask and redundant second stage regulator. Ensure there is no leakage and air has stopped flowing. Re-position the redundant second stage locking lever against the valve housing.

b. **Post-Dive Cleaning, AGA MK II FFM**

- (1) On completion of the days diving, ensure the AGA mask, redundant second stage, and first stage regulator remains fully assembled and connected to an air source. Immerse the mask and redundant second stage regulator in clean fresh potable water (e.g. bucket, garden hose, or dunk tank).
- (2) Press in the purge button on both second stage regulator and allow air to flow through the mask and both second stage regulator to ensure a complete flush is accomplished.



If diving in a pool and/or a disinfectant is used, ensure the mask and redundant second stage regulator are thoroughly rinsed with clean fresh potable water to remove any residual chlorine water or cleaning agent.

- (3) The remainder of the breathing system components must also be rinsed, ensuring no water is allowed to enter the first stage or intermediate pressure hoses.
 - (4) Turn off air supply. Purge the mask and redundant second stage regulator of all residual air pressure. Remove from air supply source. Replace the dust cap securely onto the first stage regulator.
 - (5) Shake all the remaining water out of the mask and redundant second stage. Hang to dry in such a position that any residual water will drain away from the inside of the mask and minimal strain is put on the hoses.
 - (6) Prior to storage, the entire mask is to be visually inspected for deterioration and serviceability. If any defects are observed, the mask is to be quarantined and returned to the appropriate FDU Repair Facility for servicing.
- c. **Thorough Cleaning of the AGA MK II FFM.** Clean the mask after prolonged use or when it is extremely dirty using the following procedures:
- (1) **Disassembling the AGA MK II FFM** (Refer to [Figure 4-15](#))
 - (a) Ensure that the airflow has been turned off and the mask has been purged of all residual air pressure.
 - (b) Remove the intermediate pressure hose from the second-stage by grasping the knurled hose fitting and turning it counter-clockwise. No tools are required for this procedure.
 - (c) Unscrew the two knurled screws on the communications blanking cover (23) until they are completely disengaged. Gently remove the cover and inspect both the cover (23) and the O-ring (21) for wear or damage.
 - (d) Remove the second-stage regulator by turning it one-quarter turn clockwise. Ensure the bayonet connection is disengaged and then pull gently on the second-stage to separate it from the mask.
 - (e) Set the mask assembly aside.
 - (2) **Disassembling the AGA MK II FFM Exhalation Assembly** (Refer to [Figure 4-16](#))
 - (a) Unscrew the large locking ring (16) and remove the positive pressure attachment (2) from the valve housing (24).
 - (b) Hold the positive pressure attachment (2) and remove the diaphragm assembly (7) by putting a fingernail between the outer flange of the diaphragm assembly (7) and the positive pressure attachment cover (4).
 - (c) Carefully separate the components as follows:
 - (i) Gently pull out the sealing disk (8) from the diaphragm assembly (7).
 - (ii) Pull the exhalation diaphragm (9) off the valve seat (11).

- (iii) Remove o-ring (15) from the diaphragm holder (14).
- (iv) Remove guide disk (5) and the positive pressure spring (6) from the positive pressure attachment cover (4) as a unit.
- (v) Do NOT disassemble the exhalation assembly any further for cleaning purposes.
- (vi) Do NOT remove the valve insert (27) from the valve housing (24).
- (vii) Wash all of the exhalation components (removed above) in soapy water. A soft bristle brush may be utilized if necessary.
- (viii) Thoroughly rinse all components in clean fresh water.
- (ix) Allow all components to dry thoroughly before reassembly.

(3) Reassembling the AGA MK II FFM Exhalation Assembly (Refer to [Figure 4-16](#))

- (a) Before reassembly inspect and lubricate (sparingly) all rubber parts using Dow Corning® 111 silicon lubricant.
- (b) Place cover (4) open-end-up on a table.
- (c) Place the guide disk (5) and the positive pressure spring (6) into the cover assembly (4) with the guide disk spindle and spring facing upward.
- (d) Press the exhalation diaphragm (9) onto the centre protrusion of the valve seat (11).
- (e) Insert the spindle of the sealing disk (8) through the centre of the valve seat (11). The sealing disk when properly positioned should cover the raised centre portion of the exhalation diaphragm (9).
- (f) Press the diaphragm assembly (7) (with guide pin (12) facing up) straight down on the spring into the cover (4). It should “pop” into place. Take care to push the assembly together straight. Do NOT bend the exhalation spring at an angle.
- (g) Check that the unit is working correctly by pressing down lightly on the guide pin (12) a few times, it should move freely.
- (h) Replace the O-ring (15) in the groove of the diaphragm holder (14). Ensure that O-ring (15) does not become crimped on reassembly.
- (i) Positive pressure mask only: Ensure the positive pressure lever (23) is positioned AWAY from the valve housing.
- (j) Reattach the positive pressure attachment (2) onto the valve housing (24) as follows:
 - (i) Place the locking ring (16) on the valve housing (24).
 - (ii) Screw the positive pressure attachment (2) in place with locking ring (16).
 - (iii) Check that the guide pin (12) is correctly placed in the slot of the lever assembly (28).
 - (iv) Positive pressure mask only: Positive pressure lever (item 23) is positioned away from the valve housing (24).

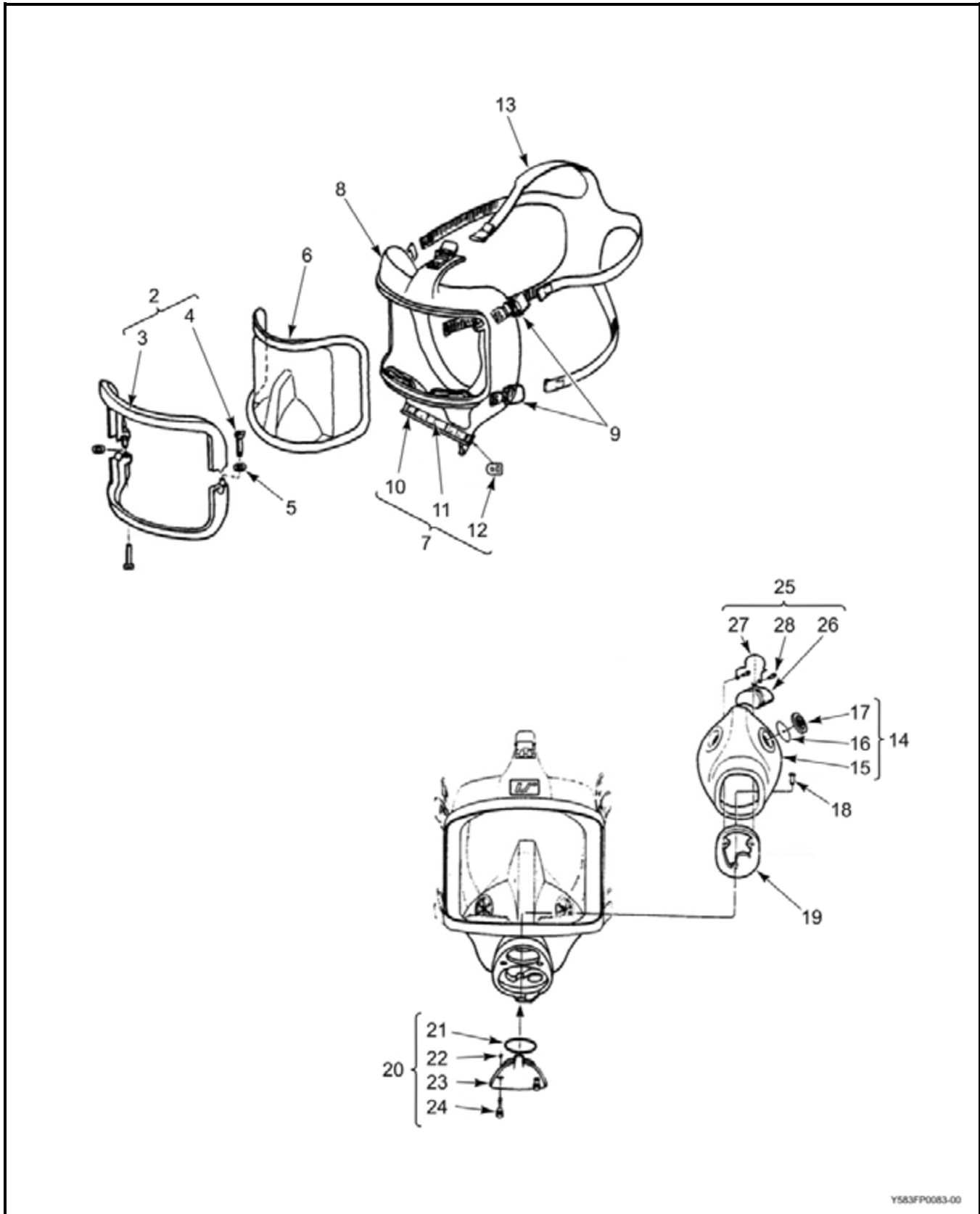

Y583FP0083-00

Figure 4-15 AGA MK II FFM Disassembly

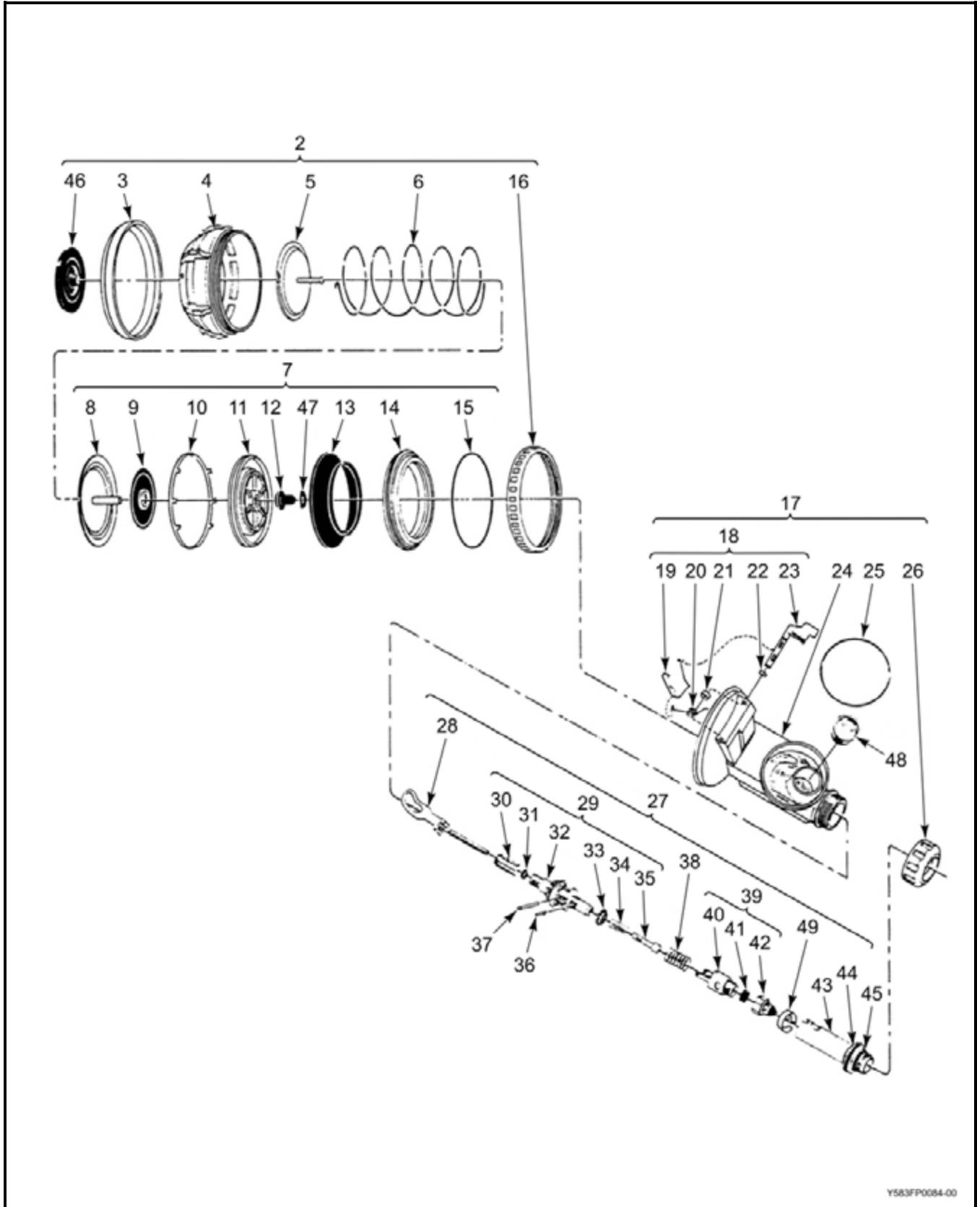

Y583FP0084-00

Figure 4-16 AGA MK II FFM Exhalation Assembly

(4) **Reassembling the AGA MK II FFM to the Second-stage Regulator**

- (a) Attach the second-stage breathing valve bayonet connection onto the mask assembly, ensuring that the O-ring ([Figure 4-16](#), Item 25) is in good condition.
- (b) Hold the mask with the front of the visor facing toward you.
- (c) Insert the second-stage into the lower hole in the face of the mask retaining plate. The exhalation side of the second-stage should be pointing toward your left at about a 20° angle.
- (d) Push the regulator into the mask ensuring that the bayonet O-ring on the regulator is all the way in the bayonet fitting of the mask and no longer visible all the way around.
- (e) Holding the mask firmly turn the second-stage counter-clockwise locking in the bayonet fitting. This can be seen by looking at the underside of the mask and regulator as it is turned.
- (f) Reattach the blanking plate ([Figure 4-15](#), Item 23) to the front of the facemask above the breathing valve. Again, ensure that the O-ring is present and in good repair.

d. **Function Testing after Cleaning, AGA MK II FFM**

- (1) Positive pressure mask only: Ensure the positive pressure lever is turned inward against the regulator housing.
- (2) Connect the first-stage to a pressurized dive cylinder.
- (3) Slowly OPEN the cylinder valve to pressurize the system.
- (4) No flow of air should be heard. A flow indicates a leakage.

415. LIGHT-WEIGHT SURFACE-SUPPLIED DIVING EQUIPMENT (LWSSDE)

1. The Light-Weight Surface-Supplied Diving Equipment (LWSSDE) is used to provide voice communication and a regulated supply of compressed air to a surface-supplied diver. This system provides greater endurance than CABA and is compact, lightweight and deployable from a variety of diving platforms.

2. The LWSSDE is used with compressed air to a maximum depth of 54 msw. Note to D Dive S: Manufacture recommend max of 50 msw or 164 ft.

3. **LWSSDE ensemble.** The LWSSDE ensemble consists of the following:

- a. **AGA Divator MK II Full Face Mask.** The Superlite 17B helmet may be used in conjunction with LWSSDE in **air mode only**. This is currently restricted to Clearance Divers. Diving procedures will be IAW B-GG-380-000/FP-003 as modified for this equipment.
- b. Protective insulating suit (wetsuit or drysuit),
- c. Diver's harness (Windak vest or BDCMVBC),
- d. Emergency air supply cylinder (850-litre (30 cu ft), 2265-litre (80 cu ft) or 2832-litre (100 cu ft) @ 205 bar) complete with cylinder valve and first-stage regulator with IP hose to the side block assembly (SBA) and redundant second stage regulator,
- e. Side block assembly (SBA) routes primary and emergency air to divers FFM,
- f. Light-Weight Surface-Supplied Air Control Panel (LWSSACP) ("diving console"),

- g. Diver's communications unit c/w headset and boom mike,
- h. Two 80 m-length composite umbilicals,
- i. Two 2 m-length high-pressure hose whips with CABA yoke connectors and bleed valves,
- j. Fins or weighted boots, and
- k. Weights and/or integrated weight system.

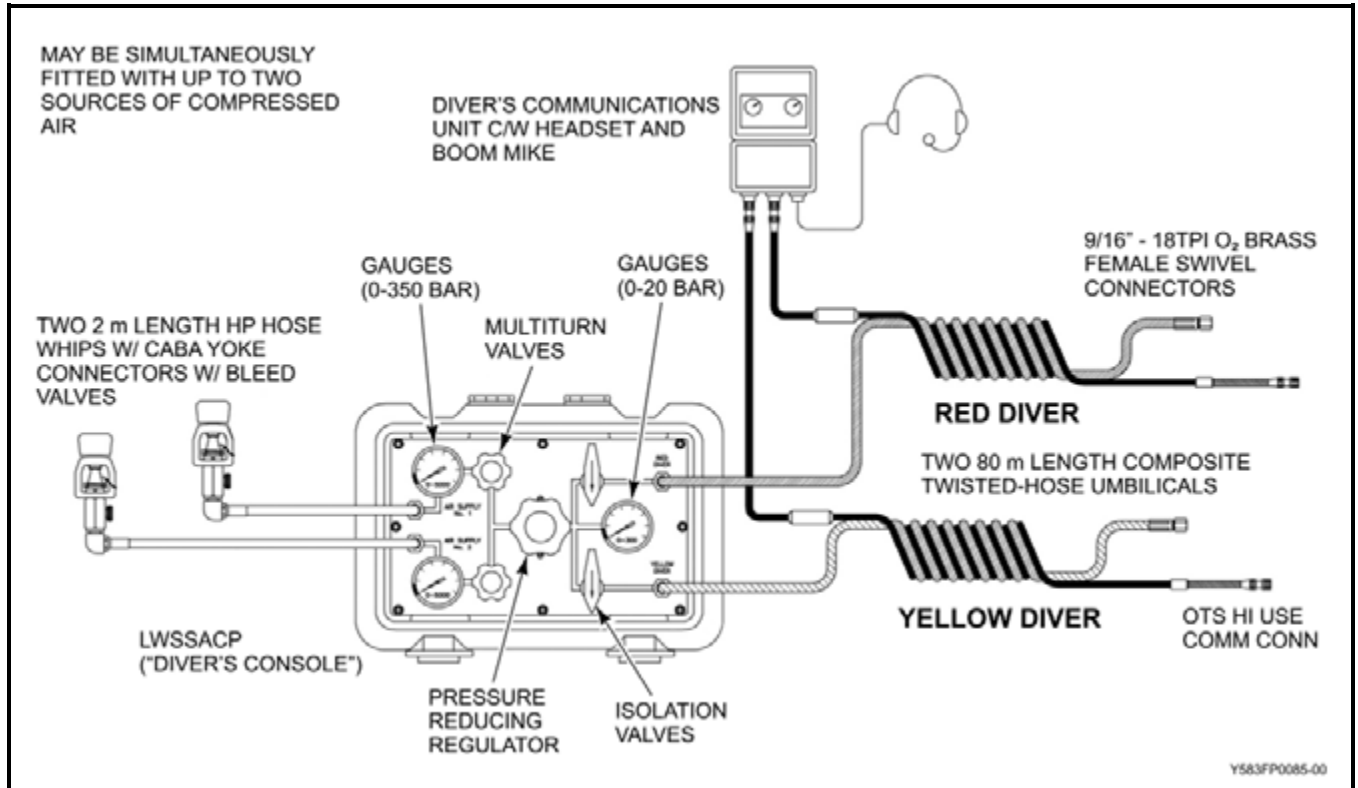

Figure 4-17 LWSSDE Console, Yokes and HP Hose Whips, Comms and Umbilicals



Only diver's breathing air is authorized for use with the LWSSDE system. The LWSSDE system is not compatible with any breathing gas having enriched levels of oxygen.

4. Twisted Hose Umbilical

- a. The umbilical provides the diver with breathing air, communications and acts as a lifeline.
- b. The twisted hose umbilical used with the LWSSDE is comprised of an Aqualite HAL0106 breathing hose made up of an extruded, specially compounded polyurethane tube, reinforced by a high-strength yarn and a fully bonded, brightly coloured (yellow/red), highly visible outer polyurethane cover. It is laid-up helically in a full 360° construction with a 18/4 90C SOW water-resistant communications cable. An AMP connector is spliced to the dry end and a Hi Use connector is spliced to the wet (diver's) end.

- c. The umbilical is manufactured as a complete assembly and is delivered in 80-metre lengths with the breathing and communications lines layered together like a two-strand rope. The communication cable is designed to take the strain and no separate strain member is required.
- d. Working pressure of the umbilical is 35 bar (gauge). Nominal burst pressure is 140 bar (gauge)
- e. Two welded D ring are whipped on the umbilical at the divers end.
- f. The configuration of the umbilical and fittings at the divers end make the coupling quick and easy to connect and disconnect at the side block. Once connected it cannot be released accidentally underwater.
- g. The umbilical can support the full weight of the diver in any configuration.
- h. It should be flushed through with air and capped (blanked) after use.
- i. Stow it in a clean, dry and well-ventilated area when not in use.

j. **Air Purity Testing of the Umbilical**

- (1) The testing of air purity shall be IAW D-87-003-000/SG-001. Samples must be taken from both Air Supply No. 1 and No. 2 at the diver's end of the umbilical. This process will test both the Diver Console and the umbilical.

- (a) An umbilical that has not been tested shall NOT be used.

- (b) If umbilical integrity is in doubt, the umbilical is to be returned to the appropriate FDU for inspection.

- k. **Planned Maintenance of the Umbilical.** Planned maintenance of the umbilical is detailed in C-87-250-000/NY-001 and is to be performed by qualified Clearance Divers or trained combat divers and port inspection divers.

- l. **Umbilical Markings.** As the umbilical is brightly coloured (yellow/red), conventional lifeline markings are changed to positively mark intervals on the umbilical. The markings shall be IAW [Article 124](#).

5. **Light-Weight Surface-Supplied Air Control Panel (LWSSACP)**

- a. The LWSSACP (or "diving console") is lightweight, compact and portable. It is designed to supply breathing gas to one or two divers and allows for two independent air sources. Its primary function is to reduce the pressure from the air supply and route it onward to the divers' umbilical.
- b. Two high-pressure braided stainless steel air supply whips route compressed breathing air from CABA cylinders to the inlet connection at the left side of the diving console.
- c. Two 5000-psi gauges adjacent to the inlets indicate air pressure supplied to the console.
- d. The multi-turn isolation valves allow for the selection of either air source.
- e. High-pressure (HP) air is then routed through a single, pressure-reducing regulator (TESCOM) located in the console's centre. This regulator reduces the HP air and allows output adjustment up to 300 psig. Downstream of the TESCOM regulator is a 20 bar gauge to monitor the outlet pressure supplied to the two quarter-turn isolation valves which route the air respectively to DIVER 1 (Red Diver) and to DIVER 2 (Yellow Diver) outlet fittings.



When not in use, the diving console inlet and outlet fittings must be sealed (blanked) to prevent contamination.

- f. This console has been extensively field tested and proven reliable in severe cold, however some freeze-ups have been experienced in ambient temperatures close to 0 degrees Celsius. Owing to the small mass of this console, and its exposure to the ambient environment during operations, particular attention must be paid to symptoms of freeze-up, which may prevent the TESCOM regulator from functioning properly. If the internal components become ice-coated it may become impossible to alter the regulated output pressure. Protect the panel prior to use, keep it as warm and dry as possible while installed in the boat, and ensure dry diver's air. These measures will reduce the likelihood of freeze-up.
- g. As depth increases or decreases the pressure delivered to the diver(s) via the umbilical(s) must be manually adjusted, as there is no automatic adjustment of the intermediate pressure delivered to the diver(s). The diving console attendant must pay particular attention to diver depth and adjust the pressure-reducing regulator to ensure air is delivered to the diver at the correct over-bottom pressure.
- h. Required over-bottom pressure for every 3-metre increment is shown at [Figure 5-7, LWSSDE AGA MK II FFM Over-Bottom Air Supply Pressure Adjustment \(msw/bar\)](#).

NOTE

Where two divers are on a common supply, over-bottom pressure must be set for the deeper diver.

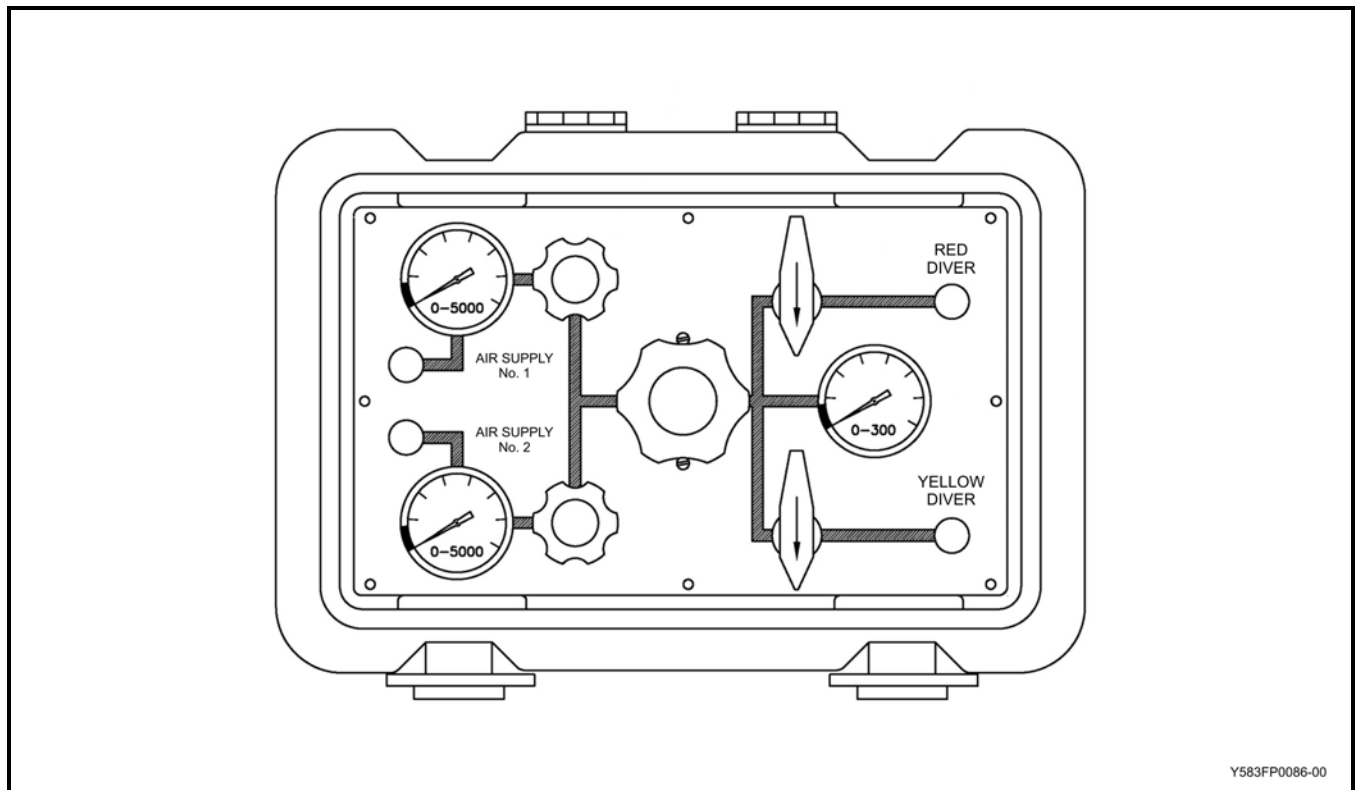

Y583FP0086-00

Figure 4-18 LWSSACP (Diver's Console)

6. **Side Block Assembly (SBA)**

- a. The SBA is a manifold that receives breathing air from the umbilical or the emergency cylinder then directs the flow to the divers FFM. The breathing air flows from the umbilical through a non-return valve to the main air inlet port on the side block assembly (SBA). The SBA is secured on the right shoulder strap of the Windak vest or BC.
- b. The diver's emergency air cylinder provides air to the SBA through the emergency valve.

WARNING

It is extremely important that the non-return valve should function properly. If the main air supply fails and the non-return valve does not function as designed, the emergency air supply will be lost.

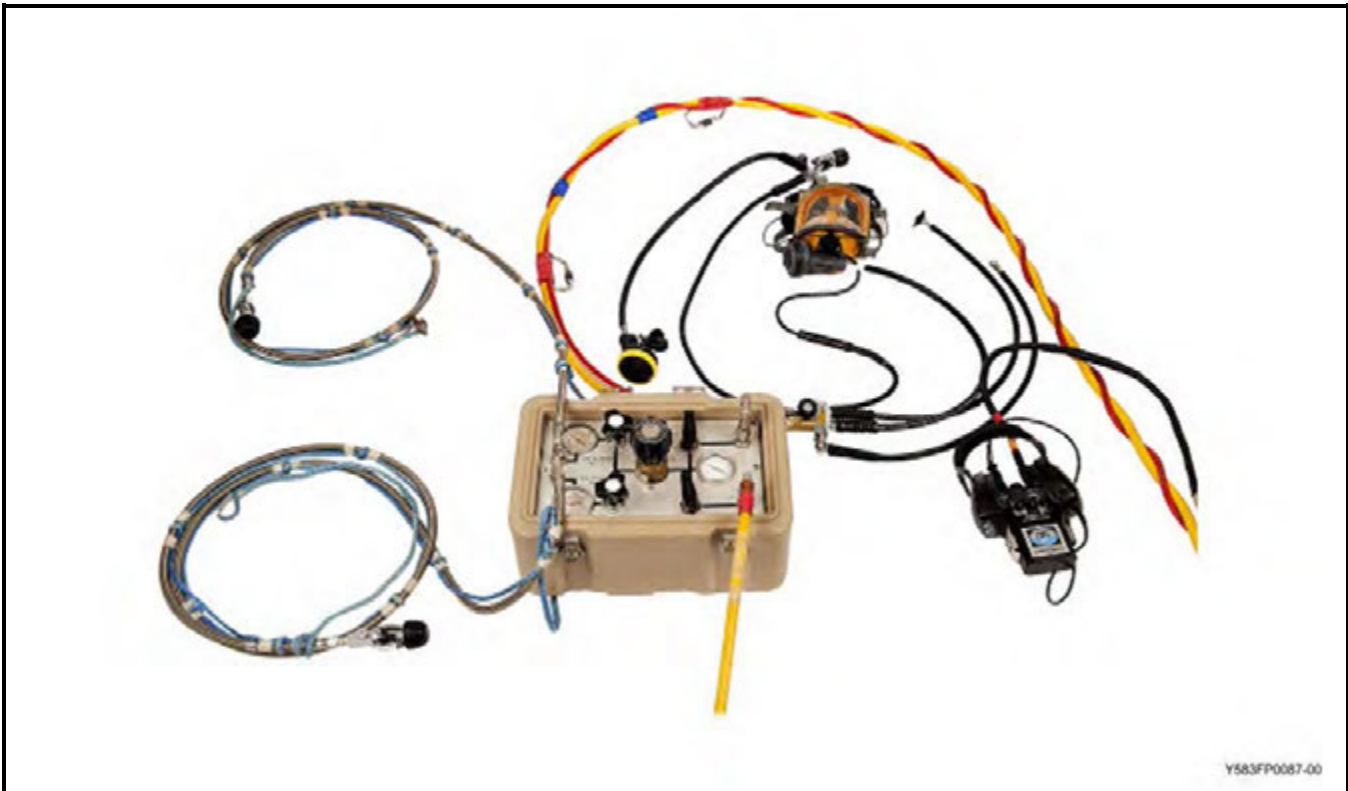

Figure 4-19 SBA, HP and IP Hose Whips – Redundant Second Stage

7. **Emergency Air Supply**

- a. Emergency air cylinder capacities range from 850-litre (30 cu ft) 2265-litre (80 cu ft) or 2832-litre (100 cu ft) @ 205 bar. Under normal circumstances, a 2832-litre (100 cu ft) emergency cylinder is to be used. The depth and nature of the task will dictate the size of emergency cylinder to be utilized
 - (1) For depths not exceeding 15 msw a smaller emergency cylinder not less than 850 litres (30 cu ft) @ 205 bar may be used.

- b. The diver's emergency air cylinder is filled with compressed air and is fitted with a K valve. It is mounted on the diver's back via a Windak vest or BC. A first-stage regulator equipped with a mini SPG and a redundant second stage regulator is connected to the cylinder. An intermediate pressure hose also leads from this first stage to the emergency valve on the side block assembly, supplying air to the divers FFM.
 - c. The emergency cylinder valve shall be slowly OPENED prior to a dive to pressurize the first-stage regulator and intermediate pressure hose.
 - d. In the event the main air supply is lost, the SBA emergency valve is slowly OPENED, supplying emergency air to the SBA and diver's FFM. If this fails to rectify the problem, close the SBA emergency valve and switch to the emergency redundant second stage regulator, don half mask if available, signal the surface, and make a controlled ascent.
 - e. In the event of an obvious failure of the AGA second stage regulator or hose, do not open the SBA. Diver is to remove the AGA full face mask, switch to the emergency redundant second stage regulator, don half mask if available, signal the surface, and make a control ascent.
8. **Maintenance (TBP)**



Y583FP0088-00

Figure 4-20 Rigging for LWSSDE Diving

416. CABA/SAR TECH RESCUE DIVING ENSEMBLE

1. The CABA/SAR TECH Rescue Diving ensemble has been developed IAW SAR operational requirements by CFSSAR COMOX and is supported by the detailed SOPs and guidance at Chapter 5, [Annex A5](#), *Guidelines for Survivor Extraction from Overturned Vessels*.

2. The purpose of the CABA/SAR TECH Rescue Diving ensemble is specifically aimed at entry into a hazardous, confined underwater environments, in order to extract survivors and provide them a breathing air source. It is similar to the CABA diving ensemble as described in [Article 413](#). With the addition of:

- a. AGA MK II FFM fitted with the Interspiro Hatch Ambient Breathing Valve (ABV) and through-water/hard wired comms.
- b. A single 2832-litre (100 cu ft) @ 205 bar diving cylinder fitted with a “J”-valve.
- c. A 368-litre (13 cu ft) cylinder, fitted with a “K”-valve, is connected to a first stage regulator with mini SPG and redundant second stage regulator. This is affixed to the front of the diver. This cylinder is designated the Survivor Auxiliary Air Cylinder (SAAC).
- d. Rescue diving procedures are detailed in:
 - (1) Chapter 5, [Annex A5](#),
 - (2) Standard Manoeuvre Manual (SMM) 60-130-2605 (SAR), *SAR Tech CABA Diving Operation*,
 - (3) SMM 60-149, *Cormorant*,
 - (4) B-GA-002-146/FP-001, *Griffon*,
 - (5) RCAF Flight Operations Manual (FOM), *Search and Rescue Technician Safe Training Practices*, and
 - (6) OJTS SAAC TRSET Directive.
- e. Diver’s lifeline shall be utilized IAW
 - (1) Chapter 5, [Annex A5](#), and
 - (2) RCAF Flight Operations Manual (FOM), *Search and Rescue Technician Safe Training Practices*.
- f. The remainder of the SAR Rescue Diving configuration is at the discretion of the on-scene SAR Tech Supervisor using guidelines and SOPs IAW Chapter 5, [Annex A5](#).

417. CABA MAINTENANCE

1. CABA divers are trained to carry out first-line maintenance only.
2. Complete overhaul, planned and corrective maintenance procedures are carried out by qualified Clearance Diver Maintainers (MOS ID 00342) only.

3. CABA divers may carry out the following first-line maintenance:
 - a. Exchange or replacement of the BC, suit inflation low-pressure hoses.
 - b. Removal or replacement of FFM and mouthpiece from second-stage regulators.
 - c. Replacement of FFM head harness and nose block(Push Pad).
 - d. Partial assembly/disassembly of the second-stage regulators exhaust assembly.
 - e. Lubrication of drysuit zipper and repair of minor drysuit holes less than 2.5 cm.
 - f. Replacement of drysuit, exhaust and inflation valves and repair of cuffs and neck seals.
 - g. Replacement of straps and buckles on fins and masks.
 - h. O-ring and "J" rod replacement on cylinders.
 - i. Repair of rips and holes on wetsuits.
 - j. Replacement of the tank straps on the BC.
4. AGA and LWSSDE first-line maintenance is described in [Chapter 5](#).
5. Malfunctioning BCs, regulators and cylinders are to be returned to the appropriate Fleet Diving Unit for repair or replacement.
6. BCs, regulators and depth gauges are to be annually inspection and tested by a FDU repair facility.
7. Cylinders are to be returned annually for inspection and testing and are also to be returned for hydrostatic testing every five years. Cylinders are NOT to be used:
 - a. After 15 months have elapsed since their last annual inspection,
 - b. When 60 months have elapsed since their last hydrostatic test.

418. DIVER'S HALF MASK

1. A half mask provides protection to the eyes and nose, insulation, and an airspace so that the diver's vision is not distorted by direct water contact.
2. To prevent squeeze the mask is designed to enclose both the eyes and nose so that air pressure inside the mask can be made equal to ambient water-pressure by expelling air through the nose. For this reason, goggles are never to be substituted for a half mask.
3. The safety glass of the mask faceplate tends to fog easily because of poor ventilation. To minimize fogging, thoroughly smear the inside of the faceplate with saliva or anti-fog compound and rinse lightly prior to donning. If the faceplate fogs during use, admit a small amount of water into the mask and sluice it across the fogged area, provided that the dive site water is not contaminated.
4. To clear a flooded half mask, gently press the upper portion of the mask to the forehead. Exhale into the mask. This will force the water out of the bottom. Gradually tilt the head backward and keep exhaling until the mask is clear.
5. A half mask should be carried by all CABA divers as a back up mask. It may be required when switching to the redundant second stage regulator. It may be carried in the diver's drysuit pocket or BC pocket.

419. SUBMERSIBLE PRESSURE GAUGE (SPG)

1. The SPG is attached to the first-stage regulator via a flexible HP hose. This gauge allows the diver to monitor air supply.
2. The SPG reading is to be compared for accuracy by the diver with the cylinder pressure test gauge after cylinder filling, and shall be tested for accuracy annually by CL Diver Techs during the diving equipment technical maintenance inspection.

NOTE

SPG accuracy tests will be within 15 bar (gauge) and SPGs found to be outside that range shall not be used.

WARNING

If at any time during a dive the indicating needle reads 35 bar or less the dive is to be terminated.

420. DIVER'S DAY/NIGHT DISTRESS FLARE

1. A combination emergency flare and smoke generator shall be carried by divers during open water diving, free-swimming and night operations.

NOTE

Flares are not permitted deeper than 30 msw. The flare is only waterproof to that depth.

2. The flare must be secured to the diver where it is readily available in an emergency. It may be strapped to the diver or placed in a BC pocket. It shall not be attached to the breathing apparatus.
3. Flares shall only be used if emergency assistance is required. They shall not be used for the routine indication of the diver's position, which is done with the indicating light (refer to [Article 428](#)).
4. Instructions for igniting the flare are printed on the flare; however, the supervisor must ensure that all divers are familiar with its operation before starting the dive. The diver must be on the surface before firing the flare and hold it well out of the water to aid visibility.
5. Regardless of their water-resistant construction, flares are subject to water damage that can render them dangerous or useless. They must be examined carefully prior to every use for signs of damage, such as rusting or swelling of the container. If in doubt, replace the flare.
6. When diving in pairs and one diver gets into difficulty, it is the responsibility of the "buddy" to bring that diver to the surface and fire the flare. The second flare must be retained in reserve and used after a suitable interval, if it is apparent that no assistance is forthcoming.
7. Day/night distress flares are to be stored in approved lock-ups when not in use for diving.

421. DIVER'S LIFELINE HARNESS

1. The lifeline harness is provided to permit a secure, load-spreading method of attaching the lifeline to a diver in a manner that will not impede the diver and that will aid in the recovery of a stricken diver. In the event that a heavy load is placed on the lifeline (for example, during an emergency), the harness will reduce injuries and can prevent excessive pinching of the diver's chest.

NOTE

The harness is neither designed for nor capable of lifting a fully laden diver out of the water.

2. The harness is worn across the diver's sternum (above or below the suit inflation valve) with two heavy stainless steel rings and VELCRO™ straps to prevent diaphragm compression or broken ribs and to ensure a safe and comfortable lead to the lifeline. The harness is designed to keep the diver in a comfortable and effectively horizontal position regardless of the angle of tending. It may be used with CABA and other equipment.
3. The front tether is slightly off-centre to allow for proper swimming at a 45° angle away from the tender. The front strap should be tightened only to a point where the diver can comfortably place a hand under the strap.
4. The harness incorporates both shoulder and front adjustments so the diver can easily adjust for different suit styles (wetsuit/drysuit) and thickness of undergarments.
5. A colour-coded size indicator is used to quickly determine if the proper size is available.

422. DIVING KNIVES

1. The CABA diver will wear two (2) knives.
2. The standard knife is heavy duty and is generally considered to be a tool.
3. The second knife is a "safety knife" designed for emergency use to free a fouled diver. It is not a work tool and shall not be used as such. It shall be worn in within the diver's "safety triangle" between the diver's neck and waistline. Either on the BC cumberbun grommets or either shoulder, provided that the sheath is secured by at least two securing methods. No ancillary equipment shall be secured to this safety knife. Refer to [Figure 1-5](#).
4. Proper retaining straps must be utilized to prevent knives from dropping from their sheaths and being lost. Operators are permitted to replace broken or deteriorated straps.
5. Knives should be kept sharp and lightly coated in silicone grease or a similar protective coating.

423. SWIM FINS

1. Flexible swim fins are important accessories for the swimming diver. Fins increase the efficiency of the propulsive force transmitted from the legs to the water. It is important for the diver to learn and practice the correct method of swimming with fins so that maximum efficiency can be maintained over long periods. Allowing the knees to bend too much is a common mistake among inexperienced divers.
2. Swim fins must fit properly. Tight or loose fins can chafe and blister the feet and cause foot cramps and poor circulation (e.g. cold feet). Fins with adjustable straps may be prone to working loose and precautions should be taken to prevent this.

424. DIGITAL DEPTH GAUGE

1. Wrist-type depth gauges are designed for use by divers to check their depth during diving operations.
2. A diver should use a depth gauge when diving in unfamiliar areas. Depth gauges may also be used to supplement soundings in deep diving.
3. Digital Depth gauges are extremely accurate (+- 0.1 m). The digital depth gauge measures the diving depth independantly of air presssure and is therefore not affected by altitude.
4. The digital depth gauge is calibrated in meters of fresh water. Therefore the saltwater depth reading will be deeper than the actual saltwater depth.
5. Digital depth gauge function should be checked prior to diving.
6. Depth gauges must be tested annually in conjunction with the Technical Inspection.

425. COMPASS

1. Magnetic compasses for underwater use can be either carried in the palm of the hand, secured by a lanyard or strapped to a swim board.
2. The graduation and lubber's line are in luminous paint, enabling the compass to be read in the dark.
3. Bearings are taken on the surface by viewing the object over the top of the compass. The course can then be swum by keeping the bearing in line with the lubber's line. With practice, courses of considerable accuracy can be attained.
4. Care should be taken to ensure the compass is level while underwater to ensure an accurate reading.



Figure 4-21 U/W Compass (Example)

426. SWIM BOARD

1. Swim boards are used in underwater swimming operations in which the diver requires that course, depth and time underwater be readily displayed. The swim boards can be made locally from a variety of materials, with slots for securing the straps of the compass, depth gauge and watch.
2. The swim board is secured to the diver by a lanyard.

427. DIVER'S WATCH

1. A waterproof and pressure-proof wristwatch is essential to the diver/supervisor for computing the time of the dive, checking the rate of descent and ascent and for timing various diving operations.

428. INDICATOR LIGHT

1. At night, an indicator light is attached to the divers shoulder, hood or cylinder valve to indicate position in the water. It can be sea cell, battery or chemical.
2. Refer to [Articles 121](#) and [145](#).

429. STROBE LIGHT

1. During night diving operations a diver must carry a strobe light (refer to [Articles 121](#) and [145](#)) in addition to an indicator light, for use if assistance required but not an emergency.

430. UNDERWATER LIGHTING

1. An underwater light can be useful in searching for or observing objects in more detail. Even in relatively clear water a light beam is full of reflections from the particles of suspended matter in the water and these reflections may prevent the diver from seeing through the beam. The light should, therefore, be placed so that the beam obliquely strikes the object to be illuminated with as little beam as possible between the diver and the object.
2. Standby divers should be equipped with hands-free lighting system whenever possible
3. Hands-free lighting offers advantages to standby divers, SAR Techs or working divers who require light with both hands free. However, divers must be aware of the potential to inadvertently cause another diver to lose night vision if not used carefully. Divers attempting to resolve a problem that requires them to work closely together may compound their difficulties by blinding each other.
4. Dive lights attached to the divers half mask or FFM shall be completely head-mounted to reduce potential fouling of the diver by a power cord. This requirement does not apply to the SAR CABA ensemble.

431. INDICATOR BUOY

1. Indicator buoys are used by divers to indicate the location of objects on the seabed or ship's hull relative to the surface position.
2. Indicator buoys can be made locally or acquired through the DND supply system.
3. These buoys are not to be confused with the Lost Diver Marker ([Article 432](#)) or with the special floats that are used for marked diving or swimming (refer to [Articles 124](#) and [223](#)).

432. LOST DIVER MARKER

1. A Lost Diver Marker is to be readily available during all diving operations. Refer to [Article 223](#).
2. In the event of a lost diver, the marker shall be thrown overboard at the diver's last known position to provide a datum for the search.
3. Until a CAF standard pattern Lost Diver Marker is introduced, the marker shall be constructed of locally procured items. The following general construction criteria should be considered:
 - a. The minimum length of the marker line must at least be equal to the maximum depth of the water.
 - b. The marker buoy must be readily visible day or night and large enough to prevent being pulled underwater by wave action or current and
 - c. The sinker must be heavy enough to prevent shifting by wind, wave or current action.

4. A 9-metre line shall be attached to the weighted end to provide a search line for the standby diver.
5. The Lost Diver Marker is to be easily identifiable from any other marker and shall not be used for any other purpose.

433. DIVER SIGNAL RECALL

1. The Diver Signal Recall is a pyrotechnic sound-producing device used by the Diving Supervisor to recall divers to the surface.

WARNING

The recall signal is sufficiently powerful to injure a diver or maim the user and must be deployed well away from divers.

2. Diver signal recalls are to be stored in approved lock-ups when not in use for diving.
3. The use of authorized Electronic Diving Recall is permitted.

434. THROUGH-WATER COMMUNICATIONS

1. Through-water communications systems involve transmission of sound or voice signals by means of a modulated acoustic wave through the water column. There are a variety of off-the-shelf systems in use in the CAF. Some function as one-way broadcasts while others operate as two-way systems.
2. One-way broadcast systems generally are made of a surface unit and hard-wired hydrophone. They are particularly useful in a training environment where the Diving Supervisor or instructor can communicate to a large group of students in a relatively confined area (such as a jetty camber or swimming pool).
3. Two-way systems generally consist of a surface unit, a hard-wired hydrophone positioned in the water to best advantage, and a diver-carried unit. The diver-carried unit consists of a tranceiver pack with transducer and a earphone and microphone assembly fitted to a FFM.
4. Through-water communication systems suffer from signal attenuation and ranges can vary considerably from those specified by the manufacturer. Caution should therefore be exercised, particularly when operating with free-swimming divers.

435. AGA MK II FFM / LWSSDE COMMUNICATIONS

1. When dived in SSBA mode, the AGA MK II FFM utilizes standard LWSSDE hard-wire underwater communications.
 - a. A water proof microphone is positioned within the oral-nasal mask.
 - b. There are two potted, waterproof earphones that are placed against the diver's ears over the wet or dry hood.
 - c. A hard-wire communications whip with a OTS Hi-Use connector connects the diver's microphone and earphones to the umbilical communications cable.
 - d. Any one of the four-wire diver communications systems in current service use is compatible with the LWSSDE diver microphone and earphone.

2. Voice communications are the primary method of communicating with the LWSSDE.
 - a. Provided communications can be maintained utilizing Manual Line Signals, loss of voice communications does not constitute an emergency.
 - b. The dive is to be aborted In the event both voice and manual line signals fail.



Figure 4-22 AGA MK II FFM w/Comms Update Picture

436. ACOUSTIC PINGERS

1. Divers can be equipped with active acoustic pingers for safety, homing and locating. These pingers are battery operated, should be lightweight and relatively low powered. They are intended for use in conjunction with a locator unit, which can be designed for surface use or for use by a rescue diver.
2. A variety of diver tracking systems used by the CAF, in all cases, batteries should be replaced before use and the effect of water conditions on nominal range should be taken into account.
3. It is strongly recommended that free-swimming divers carry acoustic pingers.

SUPPORT EQUIPMENT

437. DIVING LADDERS

1. A ladder is normally required to enable a diver to climb out of the water (except with a craft of very low freeboard).
2. Many types of ladders can be used for diving but it is important to ensure that they are firmly secured to the boat or diving platform and rigged to prevent lateral movement. The ladder should be of sufficient length to enable the diver to start climbing from the water without excessive effort.

3. The bottom of the ladder should be rounded or padded to prevent injury to a surfacing diver.
4. To prevent injury from a falling diver, divers in the water shall remain clear of divers on the ladder exiting the water.

438. AIR COMPRESSORS

1. High-pressure (HP) compressors provide a low volume of compressed air at high pressure and may be driven by a gas, diesel or electric power source. HP compressors are used primarily to supply compressed air for CABA cylinder charging or to charge a large volume bank of storage cylinders. Electric-powered and gasoline-powered models are supplied in the CAF. The high-pressure flexible lines that connect the compressor to diving cylinders are subject to wear and tear and their failure under pressure presents a serious injury hazard to personnel. Installation of strain relief lines is known to dramatically reduce the chance of injury in the event of failure of the HP line or its components. A strain relief simply acts as a snubber by restricting the movement of an HP line in the event of failure under pressure.

- a. Strain relief lines are **mandatory** for all high pressure flex lines which are over 45 cm in length and are operated at over 15 bar (gauge).
- b. The flex lines shall be replaced every five years IAW DTI 2007/03.
- c. Strain relief may be made from cable, chain, or synthetic line which has a breaking strain of not less than 1400 Kg, married to the flexible HP line at a minimum of every 45 cm, and at the ends of the hose. Marrying cord shall be high quality synthetic line 3 mm or material of equivalent strength. Tie wraps, tape, and marlin are not authorized for this purpose. Care is to be taken not to damage the HP line by excessively tight application of the marrying cord or by kinking of the HP line caused by the angle of lead of the strain relief.

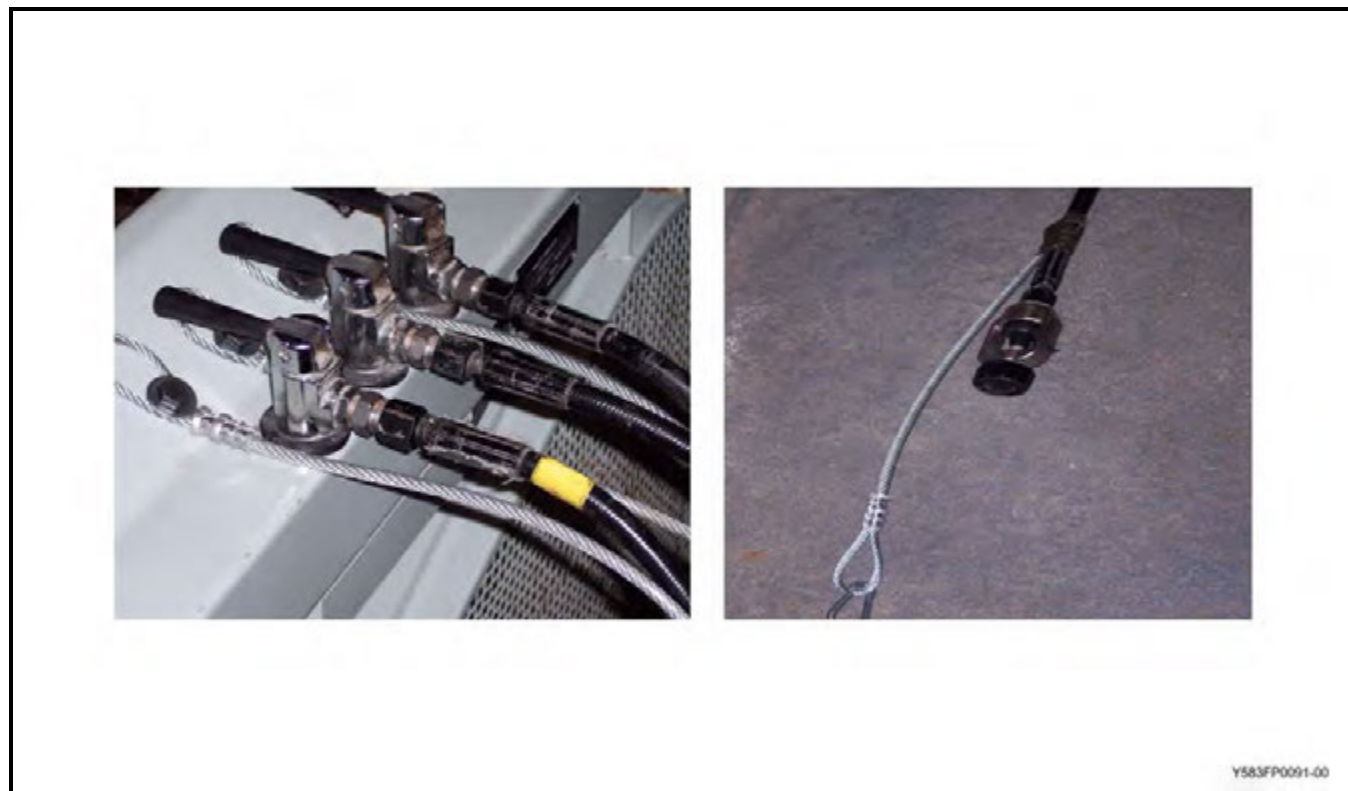

Figure 4-23

2. Each compressor is furnished with a complete instruction manual containing information on its operation, maintenance, storage and accessories. This manual should accompany the compressor unit at all times and personnel using the air compressor should be completely familiar with the information contained in it.
3. A log book shall be used to record all maintenance, air sample results and running time.
4. Never use a compressor for other than designated purpose and then only in accordance with the appropriate handbooks or technical manuals.
5. Compressed air samples are to be tested semi-annually for purity IAW [Article 140](#), *Purity of Compressed Breathing Air and Gases for Divers*.
6. Operators of the HP compressors generally are trained divers, while the maintainers are members of the engineering department. Ideally, a diving-qualified engineer should be a member of the diving team.
7. Operators and Maintainers are to refer to C-87-010-010/MS-003, *Operating and Maintenance Manual, Divers' HP Air Compressor, NSN 4310-21-869-3745 (Gasoline Engine-Driven), NSN 4310-21-869-3746 (Electric Motor-Driven)*.
8. The Diving Officer is to ensure that all divers borne are properly instructed and familiar with the operating procedures found in SOPs concerning air compressors.

CHAPTER 5
STANDARD OPERATING PROCEDURES
GENERAL DIVING PROCEDURES

501. INTRODUCTION

1. This chapter is organized to correspond to the sequences followed during an actual dive. It is designed so that a step-by-step procedure can be followed to assist in each stage of a dive.

502. DIVE PLANNING – GENERAL

1. Safe diving operations start with careful planning. Define the task, and plan carefully for the people, equipment and transportation. Emergencies or delays should be anticipated and planned for. When planning an underwater task, establish the lines of communication necessary for emergency assistance.

2. Upon completing the operation, proper reporting is important. Proper planning makes a hazardous task safer. Proper reporting makes new techniques known and usable and deficiencies in equipment or training correctable.

503. DIVE TASK PLANNING AND EMERGENCY ASSISTANCE

1. The Diving Supervisor must have all relevant information at hand before starting the dive. The information required in [Figure 5-1](#), *CAF Diving Emergency Planning and Task Definition Grid*, is to be filled-in as appropriate (this form may be locally reproduced).

2. When conducting initial dive planning, CAF diving teams may be required on occasion to designate a non-CAF recompression chamber (RCC) as their primary emergency treatment RCC during diving operations. This may be due to proximity, access, availability, etc.

3. The two most common situations involving non-CAF RCC support are:

- a. Use of civilian RCC in Canada, and
- b. Use of allied forces RCC.

4. Generally, as part of the planning procedure all aspects of the management of a hyperbaric accident must be carefully weighed and considered in advance. Consultation with a Clearance Diving Officer or Clearance Diver QL6B should be conducted early in the planning process. If required, extracts from the following publications should be requested from the local Fleet Diving Unit:

- a. B-GG-380-000/FP-005, Canadian Armed Forces Diving Manual, Vol. 5, *Hyperbaric Chamber – Operation and Treatment Procedures*, Article 1305.,
- b. ADIVP-1 (Navy), *Allied Guide to Diving Operations*,
- c. ADIVP-2 (Navy), *Allied Guide to Diving Medicine*, and
- d. D-87-003-000/SG-001, Canadian Armed Forces Standard, *Purity of Compressed Breathing Air and Gases for Divers*.

5. Local research must be carried out to identify the most appropriate RCC and its location. Foreign civil RCCs are to be avoided as the varying national standards make it that safety cannot be assured. CAF diving teams deploying abroad are expected to be a subcomponent of a larger CAF element directing support services requirements, and they are expected to utilize CAF transportable/mobile RCCs or recompression chambers of allied forces.

6. **Use of a Civilian RCC.** The following requirements and features shall be reviewed by Supervisors when determining whether a non-CAF RCC is acceptable for use:

a. **Essential Requirements of a Civilian RCC**

- (1) Capable of pressurization to 50 msw.
- (2) Medical grade oxygen used for breathing systems, meeting the standards set out in D-87-003-000/SG-001 and CSA Standard Z275.2-92, Tables 2 and 3, *Occupational Safety Code for Diving Operations*.
- (3) Proof of an air quality sample meeting standards IAW D-87-003-000/SG-001 or CSA Standard Z275.2-92, Tables 2 and 3.
- (4) Use of USN, CAF or CAF-equivalent oxygen treatment tables.
- (5) Functional communications between the Diving Supervisor and personnel inside the chamber.
- (6) There is adequate illumination of internal areas of RCC.
- (7) Functional built-in breathing system (BIBS) with external exhaust ("overboard dump"), or a designed in-chamber air flushing/ventilation system.
- (8) Reliable communications can be established between Diving Supervisor and DRDC(T) or ADMO.
- (9) Written copy of treatment profile maintained throughout the treatment and made available to the Diving Supervisor immediately upon completion.
- (10) Fitted, available and functional fire-suppression system.
- (11) Use of non-static clothing for occupants.
- (12) Inward-opening clamshell doors.
- (13) Indicating O₂ monitor mounted externally.

b. **Desirable Civilian RCC Features**

- (1) Externally-powered RCC lighting.
- (2) Internal environmental control.
- (3) Two-lock, two-place configuration.
- (4) Medical lock.

7. **Use of RCCs of Allied Forces.** Where the RCC is operated by allied forces the guidelines at ADIVP-1 (Navy) and ADIVP-2 (Navy) are to be followed. Such RCCs will generally adhere to procedures and standards of the owning nation.

504. PRE-DIVE PROCEDURES

1. Before diving, the following checks are to be carried out by the diver:

- a. Gauge all cylinders with the reserve valve down. Check cylinders for physical defects, including rust, cracks or splits, dents and loose or bent valve assemblies.

- b. Inspect O-rings.
- c. Ensure cylinder is “in-date”.
- d. After the cylinder is gauged, ensure the “J”-valve is in the “UP” position.
- e. Check the harness, bands, straps and their supports for excessive wear.
- f. Adjust the straps to fit and for quick-release.
- g. Ensure diving suit is in good repair.
- h. Check the regulator and breathing hoses for cracks, splits or punctures.
- i. Check hose connections.
- j. Fit regulator to cylinder.
- k. SLOWLY OPEN the cylinder valve and check for leaks.

NOTE

The cylinder valve is to be slowly and fully opened without jamming the valve against the Teflon packing. The historic practice of opening the valve hard against the packing and backing off + 1 turn is NOT to be used as it could damage the valve.

- l. Confirm the regulator function by taking several slow breaths through the mouthpiece. To avoid regulator freeze-up in cold weather, see the precautions given in Chapter 5, [Annex B5](#), *Ice Diving Standard Operating Procedures – CABA/LWSSDE*.
- m. Depress and release the purge button on regulator several times, then listen for leaks. Ensure the “J”-valve is in the “UP” position.
- n. Orally inflate the BC and conduct pre-dive checks IAW [Article 410](#).
- o. Check the facemask for deterioration of the rubber headband and face seal. Check the mask seal on the diver’s face. Ensure the locking rim is secured and the glass is tight and not broken or cracked. Adjust the headstrap for proper fit.
- p. Swim fins: Check the straps for deterioration. Replace as required. Adjust the straps as required. Check the blades of the fins for cracks, splits or deterioration.
- q. Inspect fastenings/retainers of diving knife scabbards. Check diving knives for sharpness. Check diving knives for accessibility and for ease of removal and replacement from the scabbard.
- r. Weighting requirements will vary according to circumstances such as freshwater vs. saltwater and deep diving. Diver weighting must be verified prior to such operations.
- s. **For a Day Dive.** Check for lifeline and buddy lines, depth gauge and day/night distress flare (open water).
- t. **For a Night Dive.** Check for lifeline and buddy lines, depth gauge, indicator light and/or chemical light, hand-held underwater light(s), strobe light and day/night distress flare.

2. If diving in pairs, the lead diver has the life line and shall secure the life line IAW [Article 124](#) and the buddy line IAW [Article 125](#). The life line shall normally lead away from the lead diver's right side and the buddy line shall be attached to the left side. The buddy diver shall normally secure the buddy line on the right side.
3. Before leaving the surface an in-water check is carried out by buddy pairs (divers check one another for leaks) or by the diver and tender, and is verified by the Diving Supervisor. Divers then adjust buoyancy and check tools and lines. Divers commence the dive on order from the Diving Supervisor.
4. A checklist version of CABA pre-dive and post-dive procedures is at [Figure 5-2](#).

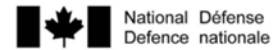

**CAF DIVING
EMERGENCY PLANNING & TASK DEFINITION GRID**

EMERGENCY PLANNING	Hyperbaric Chamber / Alternate _____	Diving Unit _____	Air-Sea Rescue / Ambulance _____	Diving Medical Officer / Hospital _____
	Location _____	Location _____	Location _____	Location _____
	Contact _____	Contact _____	Contact _____	Contact _____
	Response time _____	Response time _____	Response time _____	Response time _____

TASK DEFINITION	Task definition _____ _____ _____ _____ _____ _____ _____ _____ _____	Water conditions: Temperature _____ (°C / °F) Current _____ Depth _____ (m/ ft) Visibility _____ Obstructions _____ Ice cover _____	Geographic considerations: Location _____ _____ Weather conditions _____ _____ Logistic chain _____ _____	Air transport _____ _____ _____ _____ Other _____
	Specialized equipment _____ _____ _____ _____	Time estimate _____ _____ Time available _____	Personnel required _____ _____ _____	

Y583FP0092-00

Figure 5-1 CAF Diving Emergency Planning and Task Definition Grid

GENERAL DIVING INSTRUCTIONS

505. CABA UNDERWATER SWIMMING PROCEDURES

1. CABA underwater swimming procedures are as follows:
 - a. **Descent.** During descent, adhere to the following:
 - (1) Keep mask at ambient pressure by blowing air through the nose to prevent face squeeze and to equalise pressure in ears. If pressure equalisation is difficult, rise a few metres, clear and continue descent.
 - (2) When wearing a drysuit, to control buoyancy and prevent suit squeeze during descent the diver may be required to operate the inflation and exhaust valves on the drysuit (or BC).
 - (a) To *increase* descent rate, activate the exhaust valve.
 - (b) To *decrease* descent rate, activate the inflation valve.
 - (3) While descending the diver should expect the volume in the BC or drysuit to decrease as depth increases. The diver must activate the inflation valve to maintain the proper descent rate and to prevent suit squeeze.
 - b. **On Bottom**
 - (1) If on lifeline, keep lifeline clear and indicate arrival on bottom to attendant. On arrival stop, adjust buoyancy if necessary and orient with respect to the descent line and the work. This may be done by compass, or by observing sunlight or current direction.
 - (2) If buddy diving, do NOT detach buddy line. In general, the diver should not pass under or through obstructions. In passing around an obstruction keep in mind the side on which passed, to avoid fouling on return.
 - (3) To maintain neutral buoyancy at working depth the diver may be required to operate the inflation and exhaust valves on the BC or drysuit.
 - (4) Monitor the SPG. Whenever the needle reaches the shaded (coloured) area or reads 35 bar (gauge) or less the dive is to be terminated.
 - (5) If during the dive it become necessary to activate the reserve the dive is to be terminated.
 - c. **Ascent**
 - (1) Look up and keep one arm over the head to prevent inadvertently bumping into something.
 - (2) Breathe normally. Don't hold your breath.
 - (3) To control buoyancy during ascent the diver may be required to operate the exhaust valves on the BC or drysuit. While ascending, the diver should expect the volume in the BC or drysuit to increase as depth decreases.
 - (4) At the surface the "thumbs-up" signal is to be given until acknowledged by the Diving Supervisor.

CABA CHECKLIST

Check

1) CABA PRE-DIVE PROCEDURES To be completed by diver																		
a)	Inspect all cylinders and O-rings for damage.																	
b)	Ensure 'J'-valve is DOWN. Gauge all cylinders.																	
c)	Check harnesses / BC.																	
d)	Check hoses for damage.																	
e)	Attach regulator to cylinder(s).																	
f)	'J'-valve is UP.																	
g)	SLOWLY OPEN cylinder valve. Check for leaks. Confirm SPG reading 15 bar (gauge) +/- of cylinder gauge reading.																	
h)	Check regulator function. Take several slow breaths through the mouthpiece. In cold weather take freeze-up precautions.																	
i)	Check all accessory equipment. <table style="width: 100%; border: none;"> <tr> <td style="width: 50%;">Suit _____</td> <td style="width: 50%;">Depth Gauge _____</td> </tr> <tr> <td>Weights _____</td> <td>Watch _____</td> </tr> <tr> <td>Knives _____</td> <td>Compass _____</td> </tr> <tr> <td>Mask _____</td> <td>Hand Light _____</td> </tr> <tr> <td>Fins _____</td> <td>Floats _____</td> </tr> <tr> <td>Buddy Line / Lifeline _____</td> <td>Indicating Light _____</td> </tr> <tr> <td>BC _____</td> <td>Strobe Light _____</td> </tr> <tr> <td>Day/Night Distress Flare _____</td> <td></td> </tr> </table>	Suit _____	Depth Gauge _____	Weights _____	Watch _____	Knives _____	Compass _____	Mask _____	Hand Light _____	Fins _____	Floats _____	Buddy Line / Lifeline _____	Indicating Light _____	BC _____	Strobe Light _____	Day/Night Distress Flare _____		
Suit _____	Depth Gauge _____																	
Weights _____	Watch _____																	
Knives _____	Compass _____																	
Mask _____	Hand Light _____																	
Fins _____	Floats _____																	
Buddy Line / Lifeline _____	Indicating Light _____																	
BC _____	Strobe Light _____																	
Day/Night Distress Flare _____																		
2) CABA SURFACE CHECKOUT To be carried out by buddy pairs, or by diver and attendant. Checked by Supervisor.																		
a)	Adjust buoyancy, buddy-up.																	
b)	Check equipment operation, check for leaks.																	
c)	Check accessories.																	
3) CABA POST-DIVE PROCEDURES If in MCW conditions refer to Articles 560 – 565, <i>Diving in Contaminated Water</i> .																		
a)	Emerging divers confirm self and partner are OK or report symptoms of decompression sickness or injury.																	
b)	CLOSE the air supply valve and bleed down the regulator. Remove the regulator from the cylinders. Pull the cylinder 'J'-valve DOWN to indicate set has been used.																	
c)	After removal of breathing apparatus, inspect for any damage or defect. Any defects are to be corrected or the equipment is to be removed from service for repair.																	
d)	Insert dust cap in regulator yoke to prevent water ingress.																	
e)	Perform regulator post-dive cleaning and storage (see Fig 4-6).																	
f)	Perform BC / life vest post-dive cleaning & storage (see Article 410).																	
g)	Rinse all gear in fresh water and stow.																	

Y583FP0093-00

Figure 5-2 CABA Checklist

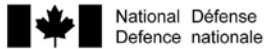

DIVING SUPERVISOR'S CHECKLIST (CABA / LWSSDE)

Check

POOL DIVING RELAXATIONS

1) CO informed of diving intentions.	
2) If diving under or near ship: <i>Diving Safety Checklist</i> (Figures 6-1 and 6-2) completed and signed.	
3) Appropriate signals displayed at dive site and in safety boat (lights / flags / shapes).	
4) Appropriate harbour authorities informed of area, work & dive duration. Weather, tides, water depth & local hazards checked.	
5) Ensure CABA / LWSSDE procedures checklist complete.	
6) Ensure pre-dive briefing understood by divers and tenders. Ensure buddy-lines, correct lifelines / floats tended as required and that air is sufficient for planned diving.	
7) Ensure diver recall signals and <i>Diving Supervisor's Handbook</i> (CF Diving Manual, Vol. 6) / B-GG-380-000/FP-007, Manuel de Plongée dans les Forces Canadiennes, Vol. 7, <i>Aide-Mémoire du Superviseur de Plongée</i> are at hand.	
8) Boat driver briefed on engine / boat handling precautions. Boat equipment complete.	
9) Divers enter water, buddy-up, check for leaks.	
10) Water entry and exit times logged on Dive Sheet. Supervisor to be aware of divers' location at all times. Full details of the dive are to be logged on Diving Supervisor's Log IAW Article 158.	
11) Watch for surface traffic. Be prepared to recall divers if they are endangered.	
12) Ensure divers remain within diving task area as designated.	
13) IF A DIVER IS SUSPECTED <u>MISSING</u>, IMMEDIATELY SURFACE ALL DIVERS TO CONFIRM LOCATIONS. IF A DIVER IS <u>LOST</u>, DEPLOY LOST DIVER MARKER.	
14) Check depth of water if area of dive is continually changing, as in seabed searches (use lead line).	
15) On completion of the dive, check the divers for injury and for any symptoms of decompression sickness.	
16) Ensure CABA / LWSSDE post-dive procedures complete.	

NOTE 'Pool Diving Relaxations' as indicated above are not required to be completed when pool diving IAW Article 146. In addition, Lifelines, Buddy Lines, and Recall Signals are not required when pool diving.

Y583FP0094-00

Figure 5-3 Diving Supervisor's Checklist (CABA/LWSSDE)

506. LWSSDE SOPs

1. When diving using the LWSSDE, [Figure 5-4](#), *LWSSDE Diving Sequence of Operations Checklist* (4 sheets), [Figure 5-5](#), *SOPs for LWSSDE Diving Checklist* (3 sheets), [Figure 5-6](#), *LWSSDE Post-Dive Checklist* and [Figure 5-7](#), *AGA MK II FFM Over-Bottom Air Supply Pressure (msw/bar)* are to be used. These checks and steps are necessary to ensure the safe operation and control of LWSSDE diving.

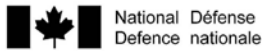

LWSSDE DIVING SEQUENCE OF OPERATIONS CHECKLIST

Check

1) SUPPORT SYSTEMS & EQUIPMENT	
a) CABA cylinders	<input type="checkbox"/>
b) Diving console	<input type="checkbox"/>
c) Appropriate manuals	<input type="checkbox"/>
d) Umbilicals	<input type="checkbox"/>
e) Communications systems	<input type="checkbox"/>
f) AGA MK II FFM (demand)	<input type="checkbox"/>
g) Emergency CABA cylinder	<input type="checkbox"/>

2) AIR SUPPLY	
a) In-date for purity tests and system certification.	<input type="checkbox"/>
b) Ensure that sufficient air is available on site.	<input type="checkbox"/>
(1) Minimum 140 bar (gauge)	<input type="checkbox"/>
(2) Double cylinders 2265-litre (11.05 li X 205 bar X 2).	<input type="checkbox"/>

Y583FP0095-00

Figure 5-4 (Sheet 1 of 4) LWSSDE Diving Sequence of Operations Checklist

LWSSDE Diving Sequence of Operations Checklist	
<i>(cont'd)</i>	
Check ✓	
3) DIVERS' UMBILICALS	
a) Ensure umbilicals have not exceeded their expiry date.	
b) Confirm that the umbilicals will pay out freely.	
c) Check hoses & cables for any damage / chafing / kinking.	
d) Check umbilical hose end connectors at both wet and dry ends.	
e) Secure inboard end of each umbilical to a cleat or other firm fastening.	
F) Purge umbilicals for 1-minute prior to first dive of the day.	
4) DIVING CONSOLE	
a) Visually inspect the console to ensure it is in good working order.	
b) Ensure all console gauges indicate zero pressure.	
c) Ensure all valves are CLOSED and the regulator is backed-off.	
d) Secure the console at the dive control area.	
e) Install HP hose whips to the inlet connectors on the console.	
f) Connect yoke/bleeder valve assemblies of HP hose whips to CABA cylinders.	
g) Connect diver's umbilicals to the console. Ensure there is no strain on the console connectors.	
h) Bring primary and secondary air cylinders online to the diving console. RECORD PRESSURES.	

Y583FP0096-00

Figure 5-4 (Sheet 2 of 4) LWSSDE Diving Sequence of Operations Checklist

LWSSDE Diving Sequence of Operations Checklist <i>(cont'd)</i>	
Check ✓	
5) AGA MK II FFM PRE-DIVE CHECKS	
a) Visually inspect all rubber / moulded plastic components and hoses for wear, damage and fatigue.	
b) Ensure the equalisation device is correctly in place.	
c) Inspect / verify side block assembly (SBA) and non-return valve operation as follows:	
(1) Disconnect umbilical from the SBA.	
(2) Confirm emergency valve on the SBA is CLOSED .	
(3) Connect emergency first-stage regulator to emergency cylinder.	
(4) Connect AGA MK II FFM to the SBA.	
(a) Positive Pressure AGA only: ensure the PP lever is toward the valve housing.	
(5) SLOWLY OPEN emergency air cylinder valve.	
(6) Fully OPEN emergency valve on SBA.	
(a) Air should not leak through the AGA, hose connections or SBA emergency valve.	
(b) No air should leak past the one-way check valve.	
(7) Invert into a cup of fresh water or use finger to confirm that there is no pressure build-up.	
(a) Any air leakage through one-way check will require replacement of the non-return valve prior to diving.	
(b) Any leakage around emergency SBA valve, AGA mask or hose connections are to be reported to the Diving Supervisor for corrective action.	
d) Connect and test communications.	
e) Check the emergency cylinder pressure (minimum 205 bar (gauge)) and ensure that the cylinder is properly secured to the backpack arrangement and 'J'-valve (if fitted) is in the DOWN position.	
f) Connect the first-stage regulator to the cylinder and the intermediate pressure hose to the SBA.	
g) Connect umbilical to SBA.	
h) Set the diving console regulator to 8.5 bar.	
(1) See Figure 5-7, <i>LWSSDE Over-Bottom Air Supply Pressure Adjustment (msw/bar)</i>	
i) Verify airflow to the mask and "Snoop" all pressurized fittings.	

Y583FP0097-00

Figure 5-4 (Sheet 3 of 4) LWSSDE Diving Sequence of Operations Checklist

LWSSDE Diving Sequence of Operations Checklist <i>(cont'd)</i>	
Check ✓	
6) AGA MK II FFM DONNING PROCEDURES	
a) Prior to donning the mask, ensure that the diver is correctly dressed in the diving suit and other equipment. Emergency cylinder air is turned ON to the mask.	
b) Diver dons the mask and the attendant assists in adjusting the head harness headphones.	
c) Confirm that the suit/stab jacket inflation valves are functioning.	
d) Secure the diver's umbilical to the diver's vest / stab jacket with locking Carabiners.	
(1) The umbilical must be secured in two locations in such a manner that it will not release accidentally or create undue stress on the connections.	
e) "Snoop" for leaks as required (mask, SBA and first-stage).	
7) AGA MK II FFM BREATHING SYSTEM CHECK	
a) Confirm that the diver is breathing from the emergency cylinder.	
b) Ensure that the purge valve is functioning correctly (unless cold weather precautions are in effect or positive pressure mask is fitted).	
c) CLOSE the SBA emergency valve.	
d) SLOWLY OPEN the main air supply.	
e) Conduct communications check.	
f) Instruct the diver to enter the water and conduct leak check.	
g) The diver signals when ready to dive.	

Y583FP0098-00

Figure 5-4 (Sheet 4 of 4) LWSSDE Diving Sequence of Operations Checklist

SOPS FOR LWSSDE DIVING CHECKLIST

1) PRE-DIVE CHECKS Supervisor

2) DONNING THE MASK

Action / Statement	By
a) Confirm that 'J'-valve is in the DOWN position, the emergency valve is OPEN and air from the emergency cylinder is ON . Confirm air to the umbilical is isolated at the diving console. Confirm function of emergency redundant 2 nd stage regulator.	Supervisor
b) <i>"REPORT YOUR DIVERS."</i>	Supervisor
c) <i>"RED / YELLOW / STANDBY DIVER EMERGENCY CYLINDER AND EMERGENCY VALVES OPEN, EMERGENCY REDUNDANT 2ND STAGE REGULATOR FUNCTIONED AND CORRECT, _____ BAR IN THE EMERGENCY CYLINDER. SUIT INFLATION AND STAB JACKET INFLATION CONNECTED. UMBILICAL SECURED WITH CARABINERS AND LOCKED. READY FOR INSPECTION."</i>	Tenders
d) Confirm diver is dressed correctly.	Supervisor
e) <i>"DIVERS DON YOUR MASKS."</i>	Supervisor
f) Red / Yellow / Standby diver, without direction, report when mask is on and breathing from emergency gas supply (e.g. <i>"RED DIVER ON EMERGENCY"</i>).	Divers
g) Supervisor confirms divers are breathing from emergency cylinders.	Supervisor
h) <i>"RED / YELLOW / STAND-BY DIVER — OFF EMERGENCY"</i> .	Supervisor
i) Divers close emergency SBA valve and report <i>"OFF EMERGENCY"</i> .	Divers
j) <i>"CONSOLE — AIR TO RED / YELLOW / STANDBY DIVER."</i>	Supervisor
k) <i>"RED / YELLOW / STANDBY DIVER - OK."</i>	Divers
l) Standby diver can remove mask and remain at designated level of readiness.	S/B Diver
m) Console air OFF to S/B diver.	Console
n) <i>"RED / YELLOW DIVER(S) UP AND OVER TO _____"</i> (entry point).	Supervisor

Y583FP0099-00

Figure 5-5 (Sheet 1 of 3) SOPs for LWSSDE Diving Checklist

SOPS FOR LWSSDE DIVING CHECKLIST		<i>(cont'd)</i>
3) DIVING		
Action / Statement	By	
a) Confirm all stations are ready to dive and no obstructions exist at entry point.	Supervisor	
b) <i>"RED / YELLOW DIVER — ENTER WATER WHEN READY."</i>	Supervisor	
c) Divers enter water at their own pace, ensuring no obstructions or divers are at entry point. Tenders confirm obstructions and ensure enough slack is available for water entry. NOTE: Consider umbilical routing.	Divers / Tenders	
d) <i>"RED / YELLOW DIVER OK."</i> Verbal or visual 'thumbs-up'.	Divers	
e) <i>"RED DIVER / YELLOW DIVER / TENDER — CONDUCT LEAK CHECKS."</i>	All	
f) <i>"RED / YELLOW DIVER WELL FOR LEAKS."</i>	Tenders	
g) <i>"RED / YELLOW DIVER — DIVE WHEN READY / ON MY COMMAND. DIVING CONSOLE OPERATOR, ADJUST OVER-BOTTOM PRESSURE AS REQUIRED DURING DESCENT."</i>	Supervisor	
h) <i>"ON THE SIDE, STANDBY TO DIVE — DIVE."</i>	Supervisor	
i) The Supervisor will note 'left surface' (LS) time and ensure correct rate of descent is maintained.	Supervisor	
j) Tenders call off umbilical depth markings.	Tenders	
k) Divers are to sound off <i>"OK — RED"</i>, <i>"OK — YELLOW"</i> in sequence on descent.	Divers	
l) During descent, divers will report when bottom/task in sight and when on bottom/at tasking. Should a problem arise during descent notify the surface.	Divers	
m) On bottom/at tasking the divers will give a sitrep and status report to the surface.	Divers / Supervisor	

Y583FP0100-00

Figure 5-5 (Sheet 2 of 3) SOPs for LWSSDE Diving Checklist

SOPS FOR LWSSDE DIVING CHECKLIST

(cont'd)

4) ASCENT

Action / Statement	By
a) Complete dive.	All
b) Supervisor notifies divers of time left in dive.	Supervisor
c) Divers ensure umbilicals are clear and tools/equipment are ready for recovery.	Divers
d) Surface personnel ready the dive site for ascent.	Tenders
e) Divers report when ready to travel: <i>"RED / YELLOW DIVER READY TO TRAVEL."</i>	Divers
f) <i>"RED / YELLOW DIVER STAND BY TO TRAVEL — TRAVEL."</i>	Supervisor
g) Supervisor notes 'left bottom' (LB) time.	Supervisor
h) Complete any required decompression.	All
i) Once a diver has reached the surface, the tender directs the diver to the exit point and maintains positive control for the exit from the water.	Divers Tenders
j) Supervisor completes the Supervisor's Log / Worksheet.	Supervisor

Y583FP0101-00

Figure 5-5 (Sheet 3 of 3) SOPs for LWSSDE Diving Checklist

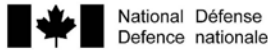

LWSSDE POST-DIVE CHECKLIST

Check

1) AGA MK II FFM	
a) Clean out mask with fresh water and VIRKON S.	
b) Rinse communication components with fresh water and allow to dry. Do NOT immerse microphone into water. Wipe clean with damp cloth.	
c) Store mask after post-dive routines IAW maintenance instructions.	

NOTE: If in MCW conditions refer to Articles 560 – 565, *Diving in Contaminated Water*.

2) UMBILICAL	
a) Blow through and cap all ends of supply hoses to preserve cleanliness.	
b) Check all fittings and hoses for damage.	
c) Stow umbilical.	

3) DIVING CONSOLE (LWSSACP)	
a) CLOSE inlet valves.	
b) Bleed down and back-off regulator.	
c) CLOSE outlet valves.	
d) Cap all connections to maintain cleanliness. Replace cover for storage.	

4) COMMUNICATIONS	
a) Turn off surface set.	
b) Charge or replace batteries.	
c) Stow set in container provided.	
d) Wash umbilical electrical connectors with fresh water and allow to dry.	

Y583FP0102-00

Figure 5-6 LWSSDE Post-dive Checklist

**LWSSDE AGA MK II FFM
Over-Bottom Air Supply Pressure Adjustment**

		DEPTH		Supply Pressure	
		msw		Bar	
msw / bar	Surface			8.50	
	5			9.00	
	10			9.50	
	15			10.00	
	20			10.50	
	25			11.00	
	30			11.50	
	35			12.00	
	40			12.50	
	45			13.00	
	50			13.50	
	55			14.00	

Y583FP0103-00

Figure 5-7 LWSSDE Over-bottom Air Supply Pressure Adjustment (msw/bar)

507. PROCEDURES FOR DIVING ON A LIFELINE

1. The diver's attendant is the link between the diver and the Diving Supervisor and is often the means of preventing disaster. The attendant must remain alert, in contact with the diver and ready to render assistance at a moment's notice.
2. **Attendant's Duties.** The following is provided to outline but not to limit the attendant's duties:
 - a. During descent the attendant must keep all slack out of the lifeline.
 - b. Once the diver is on the bottom give the diver about 1-metre of slack. This permits the diver to work unhindered but allows the attendant to maintain contact.
 - c. On receiving a signal from the diver the attendant shall send the same signal back. Emergency signals do not have to be repeated. If the signal is not understood the attendant is to wait until the diver repeats it, then return it.
 - (1) The diver will indicate understanding of a signal by repeating it. If a different signal is repeated the attendant sends the correct signal again until the diver indicates "understood".
 - d. Direction signals, e.g. left and right, are given as though the diver is facing the attendant or shot line.
 - e. If the diver does not answer a signal the Diving Supervisor shall be informed and the diver's condition should be ascertained as promptly as possible. The diver may not answer for the following reasons:
 - (1) Diver is in trouble.
 - (2) Lifelines are too slack.
 - (3) Lifelines are fouled.
 - (4) A delay may occur if the diver is too busy.
 - f. If the diver is working off the bottom the attendant must maintain a firm grip on the lines with a minimum of slack to maintain positive control of the diver.
3. If the lifeline becomes wrapped around the shot line and it cannot be cleared the Diving Supervisor should consider either using the standby diver or recovering the diver and shot line.

508. WORKING AROUND CORNERS OR INSIDE WRECKS

1. Entrapment, cut lifelines or air hoses or collapse of the structure are ever-present hazards when a diver is working in enclosed spaces or wrecks. Extra precautions are therefore necessary.
2. **Working Around Corners.** When a diver is required to drag a length of lifeline or lifeline/air hose around corners a diver should be stationed at each corner to tend lines.
3. **Wrecks.** CABA diving is NOT authorised inside wrecks other than for rescue purposes.
 - a. As detailed in [Chapters 7](#) and [8](#), only personnel trained in overturned vessel (OTV/CSRD) rescue procedures are authorised to conduct training inside wrecks
 - b. Refer to Chapter 5, [Annex A5](#), *Guidelines for Survivor Extraction from Overturned Vessels*.

509. CURRENT OR TIDEWAY

1. The Diving Supervisor must be acquainted with the times and characteristics of the tides and bear in mind that the surface stream is not normally the same as the stream at the bottom. Diving in a tide is potentially dangerous and the Diving Supervisor must decide whether conditions are likely to endanger the diver.
2. Those not experienced in tidal diving will be uncertain as to whether the tide has slackened sufficiently to allow a diver's descent. This uncertainty can best be removed by allowing the diver to try a "testing the tide" descent with the understanding that the diver should return to the surface if the tide is still too strong for managed and safe diving. The behaviour of the shot line will give a good indication of when a diver may usefully be sent down.
3. A method of diving in strong tidal streams is to securely anchor the boat upstream of the task and send the diver down the shot line, which is downstream. The diver cannot return to the surface by the shot line under these circumstances and will need to be pulled up. If necessary, the diver must let go of the shot line altogether. This method must NOT be used if the diver has to undergo decompression stops.
4. If there is any doubt of the "plodding" diver's ability to control ascent because of the strength of the current, the diver should be instructed to "keep heavy" and allow the attendant to pull the diver up slowly. Meanwhile, the diver should maintain a good grip on the shot line with legs and both hands.
5. Before the current becomes too strong to remain on the shot line, the Diving Supervisor must ensure that the diver is called up in time to complete any necessary decompression stops and to surface.
6. When divers are in swimming rig, drifting stops using a lazy shot may be safely employed. This prevents the diver being maintained at too shallow a depth because of the catenary of a fixed shot line in a strong stream. In addition, it provides much more comfortable conditions when a sea is running.
7. It is particularly difficult to clear a diver who becomes fouled in a strong tidal stream.
8. A strong swimmer can only maintain a speed of one knot, with bursts of speed of up to two knots. Swimmers must practice using the current to assist them in their tasks.

510. DIVING LIMITS AND HAZARDS – CURRENTS AND TIDAL STREAMS

1. The adverse effects on divers operating in currents and strong tidal streams are numerous. Divers attempting to maintain a fixed position on a task, while in fast flowing water, will be subjected to enormous forces. These may be exerted directly upon divers and their equipment, or translated via lifelines or buddy lines. A single diver facing a current between two to six knots (about 1 to 3 meters/sec) may experience forces between 50 to 700 lbs, depending upon orientation to the current and equipment worn. Buddied divers on a single lifeline could double these forces on the line. Working against such forces will quickly exhaust a diver, and a minor incident can escalate rapidly into a life-threatening emergency. There is also a high risk of entanglement, loss of breathing supply, loss of equipment components, embolism, and impact injury. This section outlines the potential hazards, procedures to reduce risks, and consideration when planning operations in such conditions.
2. The table below illustrates current speeds in relation to diving equipment. Operating in currents exceeding those listed is not only ineffective, but a severe hazard to the diver. Diving in currents exceeding these limits shall only be carried out by order of a Commanding Officer or SAR aircraft commander, taking into account the type of diving equipment, the experience of the diver and the team, and the operational necessity. These limits do not apply to towed diver search methods, which are specifically designed to account for this and can offer some protection from the water forces, plus offer methods for the dive to abort the search with relative safety.

CABA/LWSSDE	Maximum Water Current		
	Knots	km/Hour	m/sec
Initial Training	1.5	2.75	.75
Proficient Diver	2	3.75	1
Ice Diving	1	2.0	0.6

Figure 5-8 Recommended Current Limits

3. **Surface Current Generated by Wind.** Wind-generated surface currents are temporary and depend on the force, duration, and direction of the wind. This surface current must be taken into consideration, especially when working on or near the surface, and when diving on moored vessels or installations. It must also be remembered that an anchored vessels generally “sails” through a regular figure-eight pattern around the mooring centerline and that divers must constantly swim to maintain a position on the hull.

4. **Current and Fast Water Hazards.** The characteristics of rivers and other fast water hazards vary considerably. Factors in addition to the current velocity must be considered. By identifying potential hazards, divers and supervisors will be able to conduct diving operations with less risk to the divers and greater possibility of mission success. Significant factors to consider are:

- a. **Underwater Obstacles.** There is the potential for divers to become fouled on objects underwater. The hazard increases in currents, especially near logs, rock outcrops, tree roots, abandoned equipment, and debris from destroyed infrastructure.
- b. **Floating Objects.** Objects carried by the current, on or below the surface, pose an extreme risk to a diver, particularly during floods and spring run-off, when divers are often called to assist. If the situation allows, a snag line, boom, or fence may be positioned upstream of the dive site to reduce the risk of material being carried in the current. The snag line or boom must be monitored in case large objects, or a large amount of objects, break free.
- c. **Whirlpools and Eddies.** These hydraulic effects are caused by natural and manmade obstructions to current flow. Eddies and whirlpools can disorient and trap a diver.
- d. **Current Fluctuations.** Precipitations, tides, and structures such as dams and lock systems can affect the water levels or volume of water and current velocity. Precipitations and its effect on the waterway must be considered and can be usually forecasted. Hydrographic publications can provide useful data. The existence of upstream dams and similar systems must be determined, as well as the controlling authority and their operating procedures. Hydroelectric dams, in particular, may release large volumes of water without warning.

- e. **Water Turbidity.** Rapid and turbulent currents generally cause reduced or nil visibility, as the bottom sediments will be carried up into the water column.

5. **Equipment Considerations.** The following must be considered when diving in currents:

- (1) **Mask and Regulators.** Strong currents will tear off masks and can also cause regulators to free flow by pressing against the purge mechanism. In zero visibility, this could lead to rapid air consumption undetected by the diver, owing to the other turbulence around the head and mask. The use of a full-face mask and orientation of the diver to the current can reduce these risks.
- (2) **Weights.** Adding weights or donning a weighted vest may assist in maintaining stability and depth. Emergency surfacing and the ability to ditch weight must not be overlooked.
- (3) **Surface Supplied BA.** A diver dressed in a surface-supplied system (LWSSBA or SSBA) will generally be better able to cope with strong currents. Surface-supplied systems also provide voice communication to the diver, and the umbilical has greater strength than a standard lifeline. However, the water drag on an umbilical can be heavy.
- (4) **Plodding Boots or Fins.** Fins will allow the diver greater mobility but limited stability. Weighted boots assist in stability and provide protection, however soft river bed and lake bottoms can make the use of boots difficult. A diver working on a soft bottom in a current may soon become exhausted, depending upon the task.
- (5) **Personnel Protective Equipment.** Purpose-built helmets, elbow and knee pads may be worn when feasible.
- (6) **Communications.** Standard lifeline communications in fast water are generally not effective. As depth or distance increases, line pull communications will become completely masked by the catenary formed by the current. Through water communication systems may suffer from interference or background noise created by currents. Hard wire communications audio may be reduced by turbulence noise around the divers head.

511. WATER INLET/OUTLET HAZARDS

- 1. There are two types of pressure differential that can create water inlet/outlet hazards:
 - a. The first is the **hydrostatic** pressure differential that can be found between bodies of water separated by a barrier, where one body of water is at a higher elevation.
 - b. The other is the **mechanical** pressure differential that exists when water is pulled from a lower elevation to a higher elevation, normally by a pumping system.
- 2. Any pressure differential creates the following hazards to divers: disorientation, impact injuries and entrapment.
- 3. Hydrostatic pressure differentials can be found in the following examples:
 - a. Dams.
 - b. Weirs.
 - c. Water reservoirs.
 - d. Navigational locks.
 - e. Under ice at the outlet of a lake.

- f. Accidental water damming caused by ice, debris or log jams.
 - g. Between compartments of submerged vessels, vehicles or aircraft.
4. Mechanical pressure differentials can be found in the following examples:
- a. Water/liquid treatment plants.
 - b. Industrial complexes requiring water-cooling.
 - c. Fossil fuel/nuclear power generating facilities.
 - d. Vessels and floating platforms requiring water-cooling and/or water for consumption.
 - e. Water filtration pumping systems in swimming pools and tanks.
5. Divers conducting dives in areas where there is the potential of encountering a pressure differential require the following information:
- a. Exact location of the inlet/outlet,
 - b. Safety features employed at the inlet, e.g. grates,
 - c. Flow shut-off mechanisms, if applicable,
 - d. Flow velocity at entrance of inlet/outlet, and
 - e. If flow cannot be shut off or isolated, distance at which flow has a negligible effect on divers.
6. Dives conducted at or near an inlet/outlet must comply with the following procedures:
- a. [Article 602](#) details the procedures for diving on or near ships and is to be used as a template when diving near floating platforms.
 - b. All members must be briefed on hazards and the measures used to mitigate them.
 - c. Where there is a possibility of entrapment, two-way voice communication systems must be used.

WARNING

If the diver becomes entrapped by a pressure differential, it is likely that any rescuer will also become entrapped if the flow is not halted first. The force of pressure differentials can be in the order of hundreds or thousands of pounds, and far greater than the strength of the rescuer or the lifeline.

- d. Do NOT conduct a dive without a lifeline. The attendant must be outside of the approach area.
- e. In all but exceptional cases, the flow of water must be shut off **before** the diver enters the water. Water flow can only recommence once all personnel are clear of the area. Where conditions do not allow for the flow of water to be shut off, diving can only be conducted under the authority of the Commanding Officer.



CAF DIVING SAFETY EQUIPMENT REQUIREMENTS — DIVE SITES & DIVING SAFETY BOATS

- | | |
|--|---|
| <p>___ 1) Driver in boat</p> <p>___ 2) Standby diver at appropriate state of readiness (P*)</p> <p>___ 3) Attendant for standby diver</p> <p>___ 4) Flotation devices in boat or worn</p> <p>___ 5) Dive flags / signals / shapes</p> <p>___ 6) Divers signal recall</p> <p>___ 7) Watch / clock (P*)</p> <p>___ 8) Lifeline(s) / buddy line(s)</p> <p>___ 9) CAFDTMK & O₂ resuscitator (P*)</p> <p>___ 10) Lost diver marker buoy, line & weight</p> <p>___ 11) Paddles</p> | <p>___ 12) Engine</p> <p>___ 13) Gasoline tank</p> <p>___ 14) Gasoline line</p> <p>___ 15) Dive sheets (P*)</p> <p>___ 16) PRC for safety boat shipboard contact</p> <p>___ 17) Sounding lines</p> <p>___ 18) <i>Diving Supervisor's Handbook / Aide-Mémoire du Superviseur de Plongée (P*)</i></p> <p>___ 19) Chart / map of diving area</p> <p>___ 20) Dive tools / equipment</p> <p>___ 21) Outboard motor tools</p> <p>___ 22) Spare spark plugs</p> <p>___ 23) Spare shear pin</p> <p>___ 24) Hand-held light</p> |
|--|---|

OPTIONAL

NOTES

1. Dive site / diving safety boat: optional items are shaded. All other items are **mandatory** and must be in the diving safety boat / at the dive site.
2. For pool diving the following is required on the pool deck (marked 'P*' above): items 2, 7, 9, 15 and 18.

Figure 5-9 CAF Diving Safety Equipment Requirements – Dive Sites and Diving Safety Boats

512. GUIDELINES FOR SURVIVOR EXTRACTION FROM OVERTURNED VESSELS

1. The rescue of survivors from an overturned vessel is of the more dangerous situations a CAF diver will encounter. The rescue of survivors of a marine disaster is best left to those CAF divers that have been properly trained in survivor extraction techniques *i.e.* Search and Rescue Technicians (SAR Techs) and Clearance Divers (CI Div).
2. Although it is unlikely that a non-SAR CAF diving team would be tasked to conduct a rescue, Chapter 5, [Annex A5](#), *Guidelines for Survivor Extraction from Overturned Vessels*, is designed to give the diving team some basic information that should be considered prior to the attempt.

513. ICE DIVING STANDARD OPERATING PROCEDURES – CABA/LWSSDE

1. Ice diving is a specialized form of CABA/LWSSDE diving that introduces several additional hazards to the diving environment, such as equipment freeze-up, hypothermia and diver entrapment. However, divers properly trained and experienced in under-ice and cold weather diving have an extremely low accident rate. Although ice diving techniques are not so very different, planning for ice diving operations includes additional safety precautions and equipment.
2. Refer to Chapter 5, [Annex B5](#), *Ice Diving Standard Operating Procedures – CABA/LWSSDE*.

514. TOOLS

1. Always use the proper tool for the job. Special adaptations may be required to make surface tools usable in the water. Dropped tools are easily lost in limited visibility or in silt and should have a buoyant brightly colored lanyard attached to aid location.
2. Tools that the diver carries should be fitted with a lanyard that can be slipped over the arm.
3. Since the diver can carry only a limited weight or volume on descent or ascent, arrangements should be made on the surface to ensure that the proper tool arrives at the task site at the time the diver needs it.
4. A heavy canvas tool bag fitted with drains is useful for sending tools to the diver.
5. A suitable tool line should be run from the surface to a point at hand to the diver, with sufficient angle that the tool bag will sink to the task site. A light in-haul line is used by the surface to retrieve the tool bag.

NOTE

To lower tools, attach them to a shackle on the tool line and control them in the same way as the tool bag. Care should be taken to ensure the shackle pin cannot come free while working the tool line.

515. LAZY SHOT DIVING PROCEDURES

1. Lazy shot diving is a specialized form of CABA diving. Situations may arise which make it necessary to dive in unknown waters to recover lost equipment. The lazy shot is used to control a diver's depth during in-water decompression stops when they have exceeded No-D limits IAW CAF Air Diving Tables 1S or 1.
2. A tender must be made available when lazy shot diving.

NOTE

The shot line assembly must be light enough to be physically hauled up by a minimum of two (2) persons in case of a fouling situation.

3. Supplementary decompression/lazy shot signals are used in lazy shot diving. See [Figure 5-10](#).

DIVER to ATTENDANT	
<i>At bottom:</i> 1 -PULL	I have made bottom. I have left bottom.
<i>At the first stop:</i> 1 -PULL	OK.
<i>At the first stop:</i> 2 -PULLS followed by 2 -BELLS	I have reached the lazy shot. I have disconnected the lazy shot.
ATTENDANT to DIVER	
2 -PULLS followed by 2 -BELLS	Disconnect the lazy shot from the shot line.

Y583FP0106-00

Figure 5-10 Supplementary Decompression/Lazy Shot Signals

4. **Procedures**

a. **Diving Supervisor’s Considerations in Lazy Shot Diving**

- (1) Maximum depth of the dive,
- (2) Size of team to safely carry out the dive,
- (3) Distance to the RCC,
- (4) Review “Omitted-D” procedures,
- (5) Tides, currents and wind, and
- (6) Water and air temperature.

b. **Required Equipment.** For required equipment see [Figure 5-11](#).

LAZY SHOT DIVING REQUIRED EQUIPMENT

- | | |
|---|--|
| <p>_____ 1) <u>SOUNDING LINE</u> and/or hand-held <u>DEPTH SOUNDER</u></p> <p>_____ 2) <u>SHOT LINE</u>
6m longer than maximum depth expected, 18 mm (3/4 in.) dia. synthetic line marked IAW Article 124.</p> <p>_____ 3) <u>LEAD SHOT</u>
7 – 14 kg</p> <p>_____ 4) <u>DANFORTH ANCHOR</u>
4.5 kg</p> <p>_____ 5) <u>CHAIN</u>
6 mm , 2 – 2.5 m in length</p> <p>_____ 6) <u>SEARCH LINE</u>
10 m in length, 10 mm dia. synthetic line</p> <p>_____ 7) <u>CHEM-LITE</u>
Minimum of one is required. A distinctively coloured Chem-Lite shall be attached to the lazy shot during night diving operations.</p> <p>_____ 8) <u>LAZY SHOT</u>
12 m in length, 9 mm dia. synthetic line, marked IAW Article 124.</p> | <p>_____ 9) <u>WEIGHT, LAZY SHOT</u>
7 – 14 kg (<i>the heavier is used if fast tides or current are expected</i>)</p> <p>_____ 10) <u>DIVER'S LIFELINE</u>
60 m in length, 9 mm dia. synthetic line marked IAW Article 124.</p> <p>_____ 11) <u>CARABINER</u> (<i>preferred</i>) or a Shackle
One 10 cm on a 30 cm pennant to lazy shot weight</p> <p>_____ 12) <u>SHACKLES</u>
Qty 2, to connect chain to Danforth anchor and to shot</p> <p>_____ 13) <u>FLOAT, 'NORWEGIAN'</u>
Attached to the end of the shot line prior to being lowered. Buoyant enough to keep the assembly up in the event it is dropped at depth exceeding 30 msw.</p> |
|---|--|

Figure 5-11 Required Equipment for Lazy Shot Diving

c. Diving with a Lazy Shot

- (1) Take sounding of dive site.
- (2) Lower to bottom:
 - (a) Danforth anchor (4.5 kg).
 - (b) Shot (lead, 7 – 14 kg).
 - (c) Shot line (6 m longer than maximum depth expected, 18 mm dia. synthetic, marked IAW [Article 124](#)).
 - (d) Search line (coiled, 10 m n length, 10 mm dia., synthetic).
 - (e) Chem-Lite (minimum of one attached 3 m from bottom).
- (3) Plumb the float (take up slack) and confirm depth.
- (4) Secure the dive boat to the float.
- (5) Brief diving team.
- (6) Divers enter water.
- (7) Divers descend to the bottom at a rate of 18 mpm or slower.
 - (a) Tender gives maximum lead angle on the lifeline to prevent the diver(s) from getting tangled around the shot line.
- (8) Divers on reaching bottom signal with 1– PULL (“I HAVE MADE BOTTOM”), extend anchor out from shot and continue dive task.
- (9) On the surface: secure running end to boat and clip lazy shot to main shot line.
 - (a) When no decompression stop is planned, the lazy shot may be clipped to the shot line and remain in the boat.
 - (b) The lazy shot shall be at ready notice to be lowered to the 6-metre mark.
- (10) Upon completion of the task or when the divers are recalled, the divers signal the surface when leaving bottom with 1 – PULL (“I HAVE LEFT BOTTOM”), then proceed to the lazy shot at an ascent rate of 18 ± 3 mpm.
- (11) When decompression is required, the lazy shot is lowered over the side and the divers align the lazy shot with the centre of their chests. Divers: DO NOT PASS THE LAZY SHOT. The lead diver signals the surface with 1 – PULL (“OK”).
 - (a) If the lazy shot must be disconnected from the shot line (e.g. due to currents /wind) the Supervisor will signal the lead diver 2 – PULLS *followed by* 2 – BELLS (“DISCONNECT THE LAZY SHOT FROM THE SHOT LINE”). The diver will disconnect and then acknowledge.

- (12) In a strong tideway or open sea the diving boat should be allowed to drift free to ensure that the diver is kept as close to the correct stop depth as possible. Failure to do this may cause the shot to maintain an angle and compromise the diver's decompression.
- (a) Drifting stops: The diving boat should be an inflatable, which has the advantage of riding seas well and causing minimal disturbance and hazard to the diver.
- (13) The Diving Supervisor has the lazy shot raised to the designated stop.
- (14) When the 3-msw decompression stop is completed the Diving Supervisor will have the lazy shot raised to the surface. The diver is to follow the lazy shot to the surface.

NOTE

If there is a possibility that the diver's air supply is low, and if an additional dive cylinder is available, fit it with a standby dive regulator (two second-stages) and send it down the lazy shot.

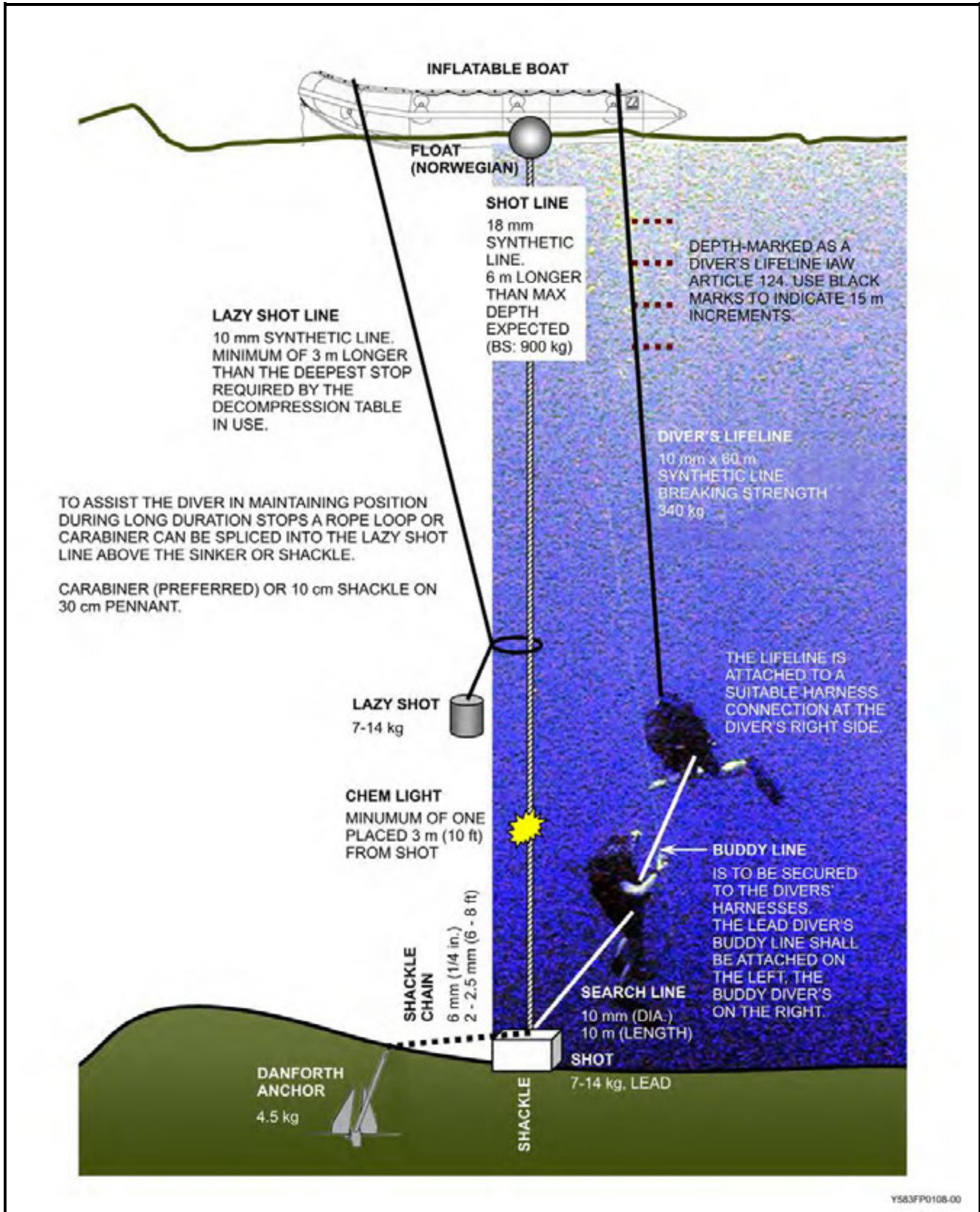

Figure 5-12 CABA Lazy Shot Diving, General Arrangement

BOTTOM SEARCHES

516. INTRODUCTION

1. A number of search procedures are described in the following articles. They are intended as a guide in searching the seabed.
2. No single search technique will be usable in all areas and under all conditions. To carry out a proper search the Diving Supervisor planning the operation must take into consideration the following:
 - a. Weather conditions,
 - b. Sea state,
 - c. Underwater visibility,
 - d. Nature of the sea bed,
 - e. Currents,
 - f. Location, size, shape and depth of area to be searched,
 - g. Size and shape of object searched for,
 - h. Accuracy of the datum and navigation method,
 - i. Water temperature,
 - j. Number of divers available and
 - k. Craft, diving equipment and support facilities available.
3. Finding an object on the seabed frequently takes more planning, time and labour than the actual work on the object itself once it has been located. Efficient and effective underwater searches therefore become an integral part of almost every diving operation.
4. The seabed search techniques described in this section are considered to be the most efficient and thorough methods of systematically covering a given area. However, they may have to be modified to suit the conditions prevailing at the time.
5. Basic seabed searches used by CAF divers are:
 - a. LIFELINE SEARCH (Refer to [Article 517](#) and see [Figure 5-13](#)).
 - b. CIRCULAR SEARCH (Refer to [Article 518](#) and see [Figure 5-14](#)).
 - c. TOWED-DIVER SEARCH (Refer to [Article 519](#) and see [Figures 5-15](#) and [5-16](#)).
 - d. LIGHT JACKSTAY SEARCHES (Refer to [Article 520](#) and see [Figures 5-17](#) and [5-18](#)).
 - (1) SNAGLINE SEARCH (Refer to [Article 521](#) and see [Figure 5-19](#)).
 - (2) GRID SEARCH (Refer to [Article 522](#) and see [Figure 5-20](#)).
 - (3) MULTIPLE-DIVER SEABED SEARCH (Refer to [Article 523](#) and see [Figure 5-21](#)).

517. LIFELINE SEARCH

1. A lifeline search (see [Figure 5-13](#)) is used off to locate objects within a limited distance.
2. The diver stretches out the lifeline until at its maximum distance 60 metres from the attendant at the start point.
3. Keeping the lifeline taut, the diver commences the search until reaching the shore or jetty or receiving a signal from the attendant to stop.
4. The diver then moves-in twice the visibility distance or two arm lengths and, again keeping the lifeline taut, searches in the opposite direction.
5. This operation is repeated until the area is covered.
6. If the object is located, the diver secures a marker line to it and swims back to the tender.

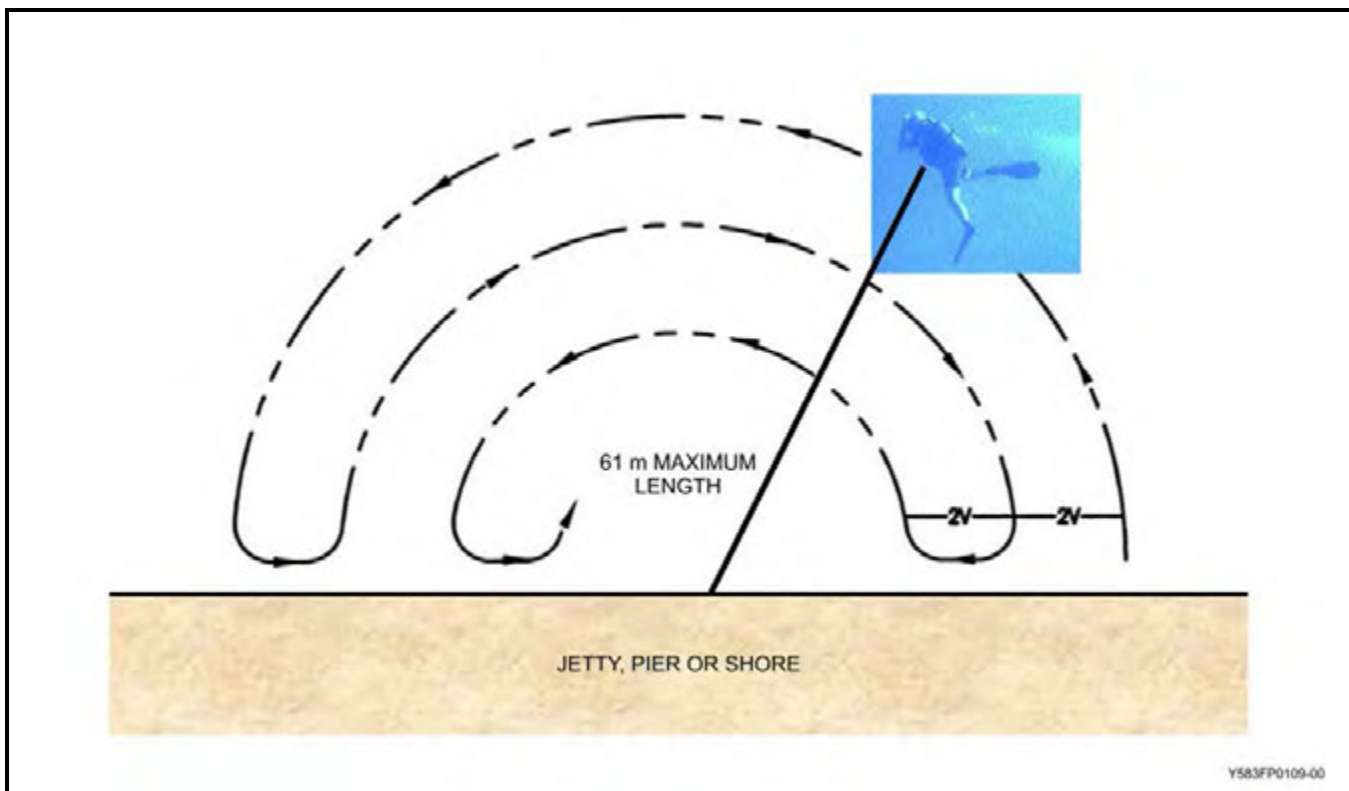

Figure 5-13 Lifeline Search

518. CIRCULAR SEARCH

1. The circular search (see [Figure 5-14](#)) is the simplest form of seabed search to undertake because it involves a minimum of people and equipment to make it effective. It is an efficient technique for covering an entire area and should be used when the position of the object to be found is known with reasonable accuracy.
2. Equipment required includes:
 - a. A buoy,
 - b. A shot line,

- c. A shot and
- d. A distance line.

3. The diver swims down the shot line, breaks out the distance line and moves away from the weight until the distance line is fully extended. At this point the diver should, if possible, note or mark the seabed as a starting point to indicate when the first circle has been completed.

4. Holding the distance line taut, the diver moves in a circle. When there is no visibility, the attendant will control the diver's position.

5. When the circle is completed, the diver moves-in on the line for twice the visibility distance and starts a circle in the opposite direction.

- a. If visibility is limited the diver moves-in on the line for two arm lengths.
- b. If a lifeline is used the surface attendant signals the diver to indicate when the circle has been completed.



If the direction of search is not reversed after each circle, the lifeline will become fouled around the shot line and signals will not be transmitted. In poor visibility this will make it impossible to conduct an efficient search.

6. Variations of the circular search may be carried out as conditions dictate.

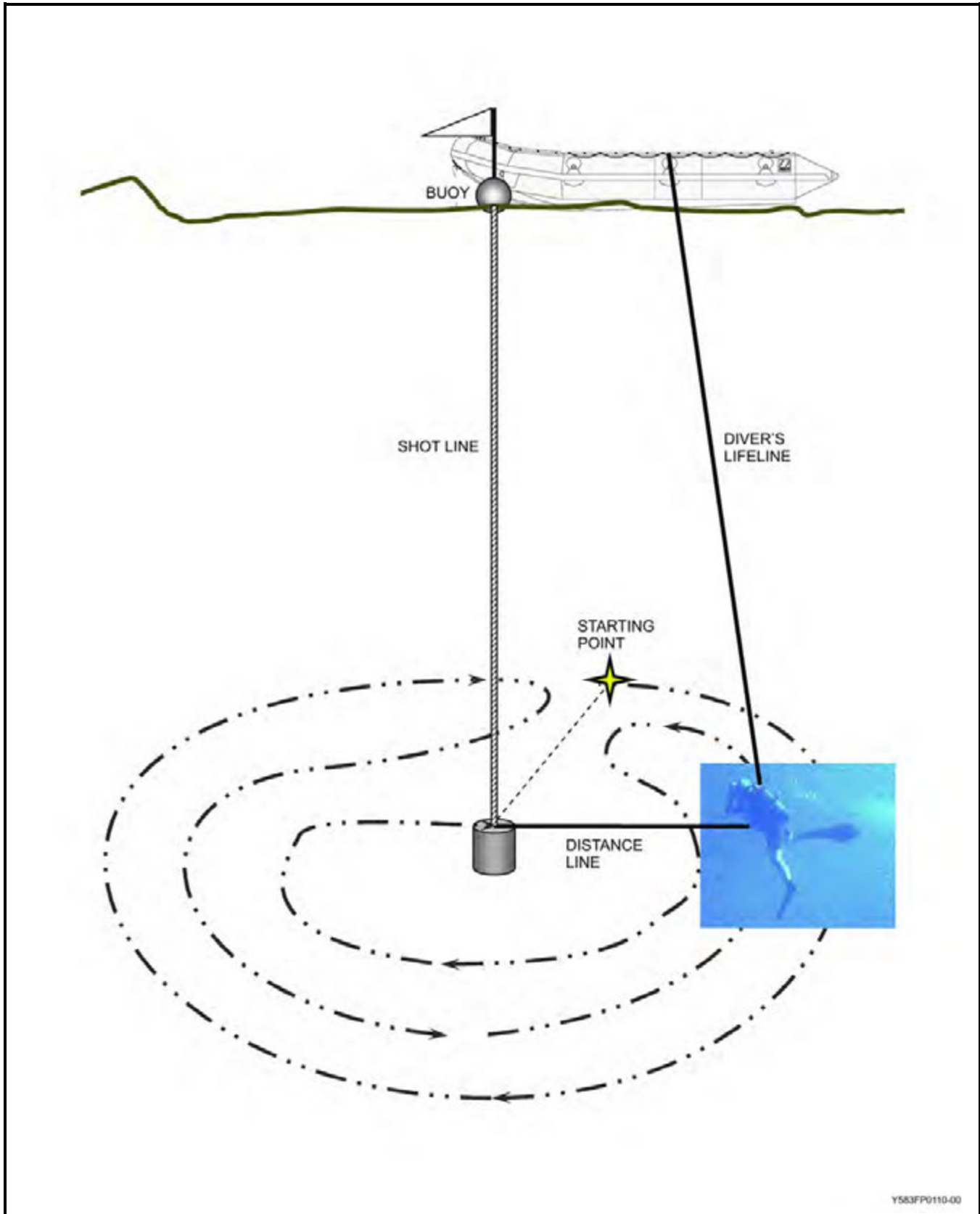

Y583FP0110-00

Figure 5-14 Circular Search

519. TOWED-DIVER SEARCH

1. The towed-diver search is used as the precursor to one of the more thorough seabed searches. It should be used only when the visibility is good and the seabed is reasonably flat. Under these conditions, the towed diver search may be used to cover an extensive area in a relatively short time.
2. The diver is towed behind the boat at a speed of 2 – 3 knots. Methods such as sinker and toggle or planing board should be used to allow the diver to control depth and some side-to-side direction.
3. The diver should be neutrally buoyant as for swimming. Since a towed diver is not active, the diving dress should be selected to provide adequate warmth, as the diver is likely to feel cold even in moderately warm water.
4. The diver and Supervisor must discuss signals for indicating speed, change (right or left), bailout and stop, as the diver will be secured to a line about 4.5 metres longer than the depth of water, with a marker float secured to the end of it.
5. During towing, the marker or float should be retained inboard to be used as a signal line.
 - a. It should be thrown overboard only when the diver bails out.
 - b. Keeping the marker line in hand in the boat also prevents it causing any unnecessary drag on the diver.
 - c. For decompression purposes the marker line is to be tied off at the maximum depth used for planning the dive.
6. The towed-diver search makes up in speed for what it lacks in accuracy. Even a well-buoyed search area will not guarantee success.

NOTE

Efficiency of searching deteriorates rapidly in adverse conditions of visibility, temperature and navigation.

Signal	From Diver	From Attendant
1 – PULL	Affirmative; Confirmation; OK.	Are you all right?
2 – PULLS	Less speed.	
3 – PULLS	More speed.	
4 – PULLS	I am surfacing.	Surface.
2 – BELLS	Shorten tow.	
3 – BELLS	Lengthen tow.	
4 – BELLS	I am bailing out.	
5 – BELLS	Let go the shot.	

Figure 5-15 Code for Passing Signals by Marker Floatline in a Towed-diver Search

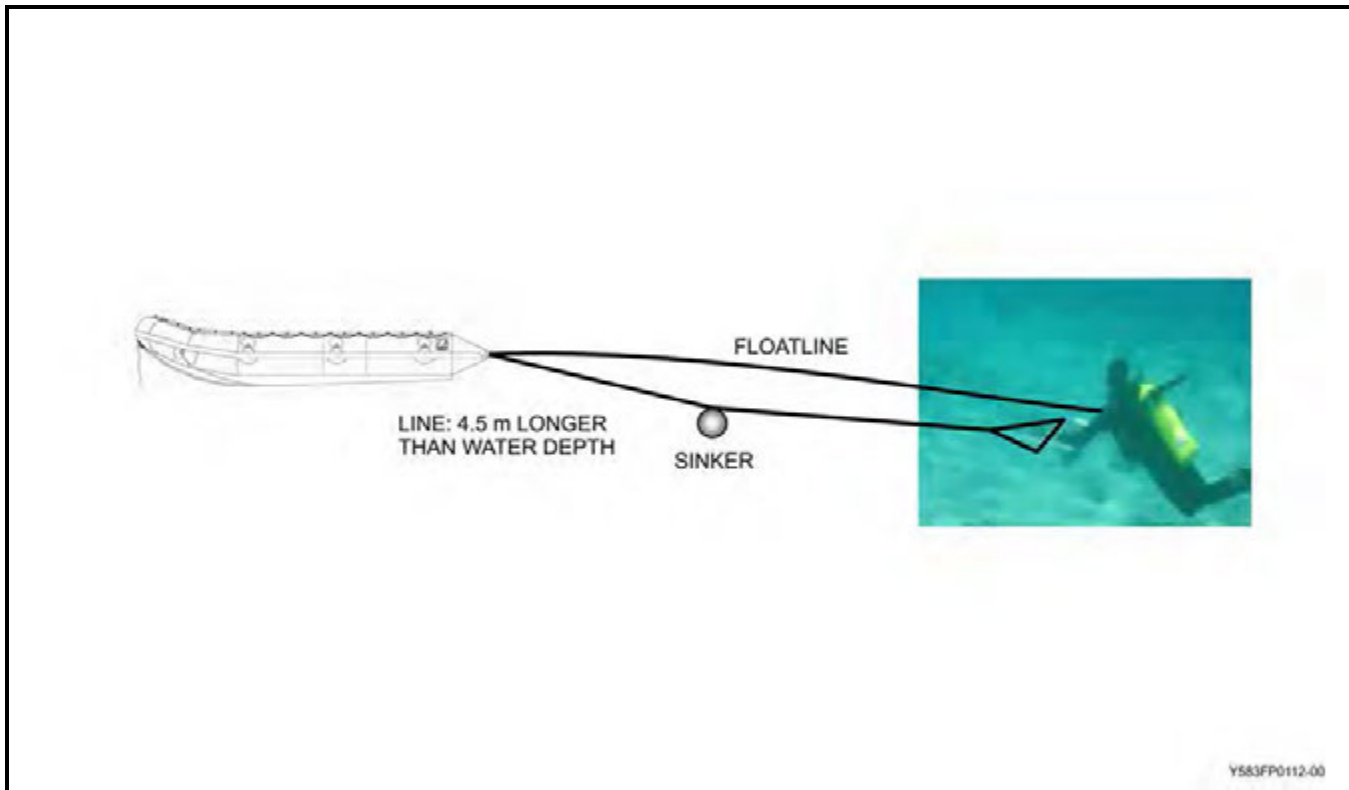

Figure 5-16 Towed-diver Search

520. LIGHT JACKSTAY SEARCHES

1. Searches conducted using the light jackstay, although slow, are the most reliable. When faced with unfavourable seabed conditions and poor underwater visibility, a search using light jackstays (*i.e.* snagline, grid and multiple-diver seabed searches) is the only search that can promise any success.
2. If an area is too big to be covered all at once, the search must be so rigged that it can be shifted to an adjacent section without creating gaps and wasteful overlaps.
3. Buoys must mark each cleared section.
4. The light jackstay and the technique for its use have been developed to lay guidelines quickly and accurately on the seabed for diving searches.
5. The jackstays are made up in 900 m lengths with sinkers, risers and floats spaced evenly every (90 m).
6. **Light Jackstay Components.** (see [Figure 5-17](#)) The equipment has been designed for assembly from local resources using the following components:
 - a. **Chute.** This is constructed of aluminium and is long enough to contain the component parts of a 900 m jackstay.
 - b. **Jackstay Reel.** This is constructed of aluminium mounted on a wooden platform fitted with a windlass handle and brake. It should be capable of carrying a minimum of (1800 m) of jackstay line.
 - c. **Jackstay.** The jackstay is a 3 mm nylon line in 90 m lengths with Inglefield clips at each end. Gun line or parachute shroud line is suitable.
 - d. **Sinkers.** A sinker is a lead weight weighing approximately 7kg with an eyebolt on it.
 - e. **Hook Lines.** These are pieces of 12 mm nylon line, half a metre in length with spring clips seized in each end.
 - f. **Risers.** Made from 12 mm nylon line with spring clips seized in each end, the finished risers are either 9 m or 18 m in length. They are combined for depths between 18 and 27 msw.
 - g. **Floats.** May be constructed from plasticised Styrofoam, each float has a 60 cm length of broom handle through the centre with a canvas flag painted day glow red nailed to the top end and a grommet containing a spring hook seized to the bottom end.
7. **Preparing to Lay the Light Jackstay.** Prepare to lay the light jackstay as follows:
 - a. The jackstay reel is secured to the floorboards of the inflatable boat.
 - b. The required number of jackstays are clipped together and reeled evenly onto the jackstay reel.
 - c. The chute is secured to the top of the portside gunwale of the inflatable.
 - d. One end of the hook line is clipped to the eyebolt on the sinker.
 - e. Risers are coiled, as illustrated in [Figure 5-18](#), to prevent fouling when being laid.
 - f. One end of the riser is clipped to the eye bolt on the sinker and the other end is clipped to the grommet on the float.

- g. The length of the riser depends on water depth:
 - (1) Less than 9 msw: 9 m risers are used.
 - (2) Between 9 and 18 msw: 18 m risers are used.
 - (3) Between 18 and 27 msw: Both risers are combined.

8. Laying the Jackstay

- a. Two people are required to lay the jackstay: one to drive and one to lay the jackstay.
- b. Lay the jackstay as follows:
 - (1) The outboard end of the jackstay is clipped to the nearest line.
 - (2) The boat is manoeuvred toward the starting position of the jackstay line and its course set along the required direction of the jackstay.
 - (3) On reaching the starting position, the first sinker is pushed out of the chute and the boat is driven at a suitable speed.
 - (4) The sinker will sink to the bottom taking the riser with it, while the float remains on the surface. The sinker pulling on the jackstay will also cause the reel to turn and the jackstay will be laid out on the seabed.
 - (5) As the jackstay runs out, it passes through the eye of the spring clip on the second hook line until the Inglefield clips joining the first and second lengths come up against the spring clip. This will then drag the second sinker from the chute. The sinker will fall to the seabed, pull out the riser and leave the float on the surface above it.
 - (6) As soon as the sinker has gone, the third hook line should be clipped to the jackstay. This procedure should be repeated until the whole jackstay has been laid, the sinkers being slid aft as space becomes available in the chute.

WARNING

If the reel handle of the jackstay reel cannot be removed, care must be taken to keep clear of it while laying the jackstay or injury may result.

9. Recovering the Jackstay

- a. An additional person will be required to reel-in the jackstay.
- b. As the sinkers are not positively secured to the jackstay but held only by the hook line clips, the jackstay should be recovered in the same direction in which it was laid.
- c. Recover the jackstay as follows:
 - (1) The boat proceeds to the first float laid and recovers it.
 - (2) The attached sinker is recovered by the individual amidships who separates it from the jackstay and secures the jackstay to the reel.

- (3) The bowman reels-in the jackstay and the boat is driven towards the next float. Care must be taken when the jackstay is reeled-in to ensure that it lies evenly and tautly on the drum, otherwise it will cause riding turns and foul during the next laying.
- (4) When the next float is reached it is recovered and the procedure repeated until the whole jackstay has been reeled-in.
- (5) While the recovery is in progress, the boat driver should maintain a course and speed that keeps the jackstay taut enough to prevent it leaving the reel, but not so taut that it bites into the turns already on the reel.

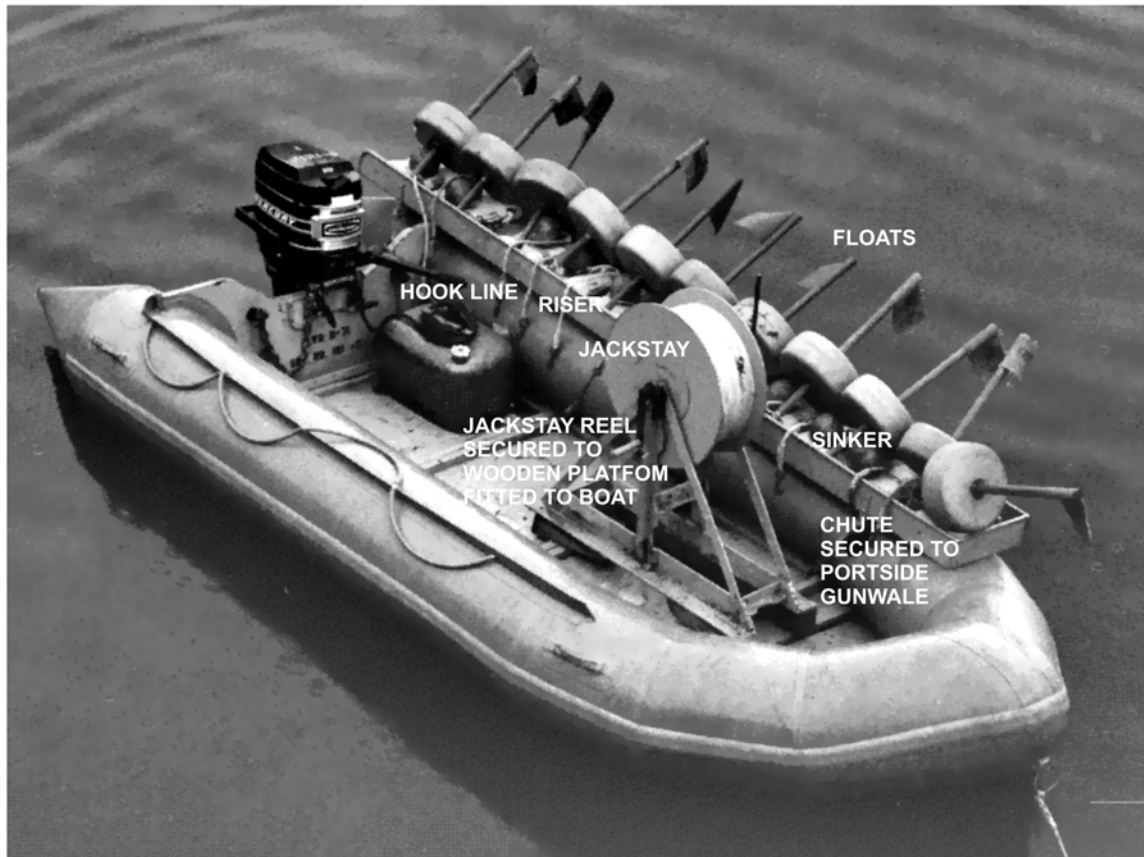

Y583FP0113-00

Figure 5-17 Light Jackstay Components Mounted on an Inflatable Boat

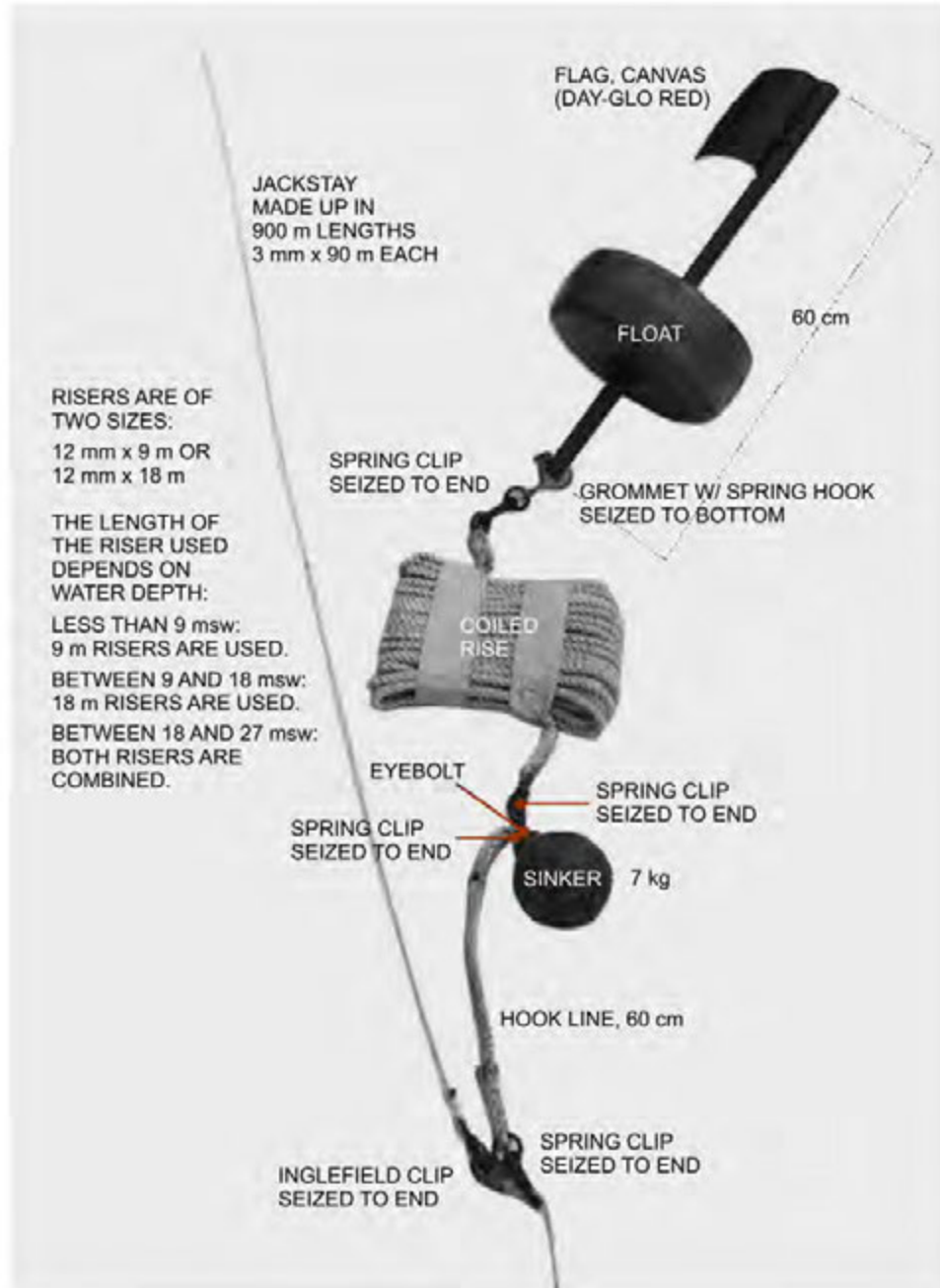

Y583FP0114-00

Figure 5-18 Riser Assembly, Light Jackstay

521. SNAGLINE SEARCH

1. A snagline search is used when the seabed is reasonably flat and clear of obstructions and the object to be found protrudes a good distance from the seabed. Jackstays are laid parallel to each other in sufficient numbers to cover the area to be searched. The length of the jackstays and the distance between them will vary to suit the situation.

2. To carry out the search, two divers descend one on each leg of the jackstay, holding between them a snagline. On the bottom, the senior diver signals to commence the search and the two divers move downstream on their respective jackstays. The divers surface at the end of their jackstays. As prearranged, one diver brings up the snagline.

3. If the snagline fouls, both divers bend the line onto their jackstays and go along it to the snag. If it is the object of the search it is marked with the marker buoy. If it is not, the snagline is cleared and the divers return to their respective jackstays and continue the search.

4. After the first leg of the jackstay is searched and if tidal/current conditions permit, the divers swim back along the next leg of the jackstay, searching as before. If the current prevents this, the swimmers surface, are picked up by the safety boat and are returned to the upstream end, where they again descend to the bottom and continue the search.

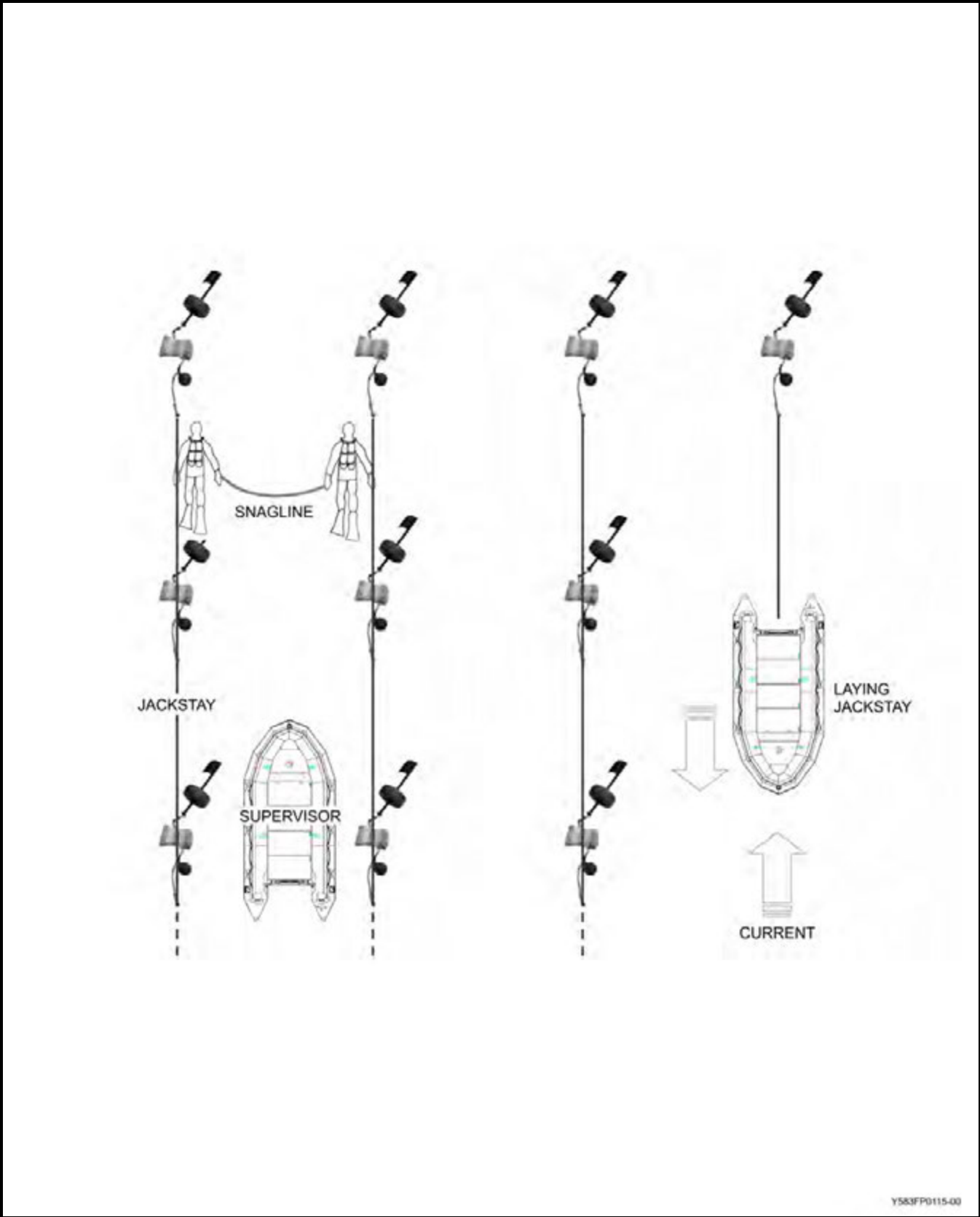

Figure 5-19 Snagline Search

522. GRID SEARCH

1. The grid search is probably the most thorough and efficient bottom search. This type of search is worked on a rectilinear basis. It entails the laying of standing jackstays to form the side of the rectangle with a movable cross-connecting jackstay for conducting the search.

2. Two divers are sent down. They start from opposite sides of the rectangle and swim along the movable jackstay, one on either side, searching their side to the maximum visibility distance. Each diver then moves his or her end of the jackstay along the standing jackstay to a position twice the visibility distance from the old one. The divers then swim back along the movable jackstay. In conditions of nil visibility, after each lap the jackstay is moved two arms' spread (an arms' spread being approximately 1.5 metres) for a total approximate distance of 3 metres.

3. When the area has been searched the grid can then be moved and re-laid immediately beside the area covered by the first grid. The search is continued as necessary, until the required area has been completely covered by a series of adjacent rectilinear searches.

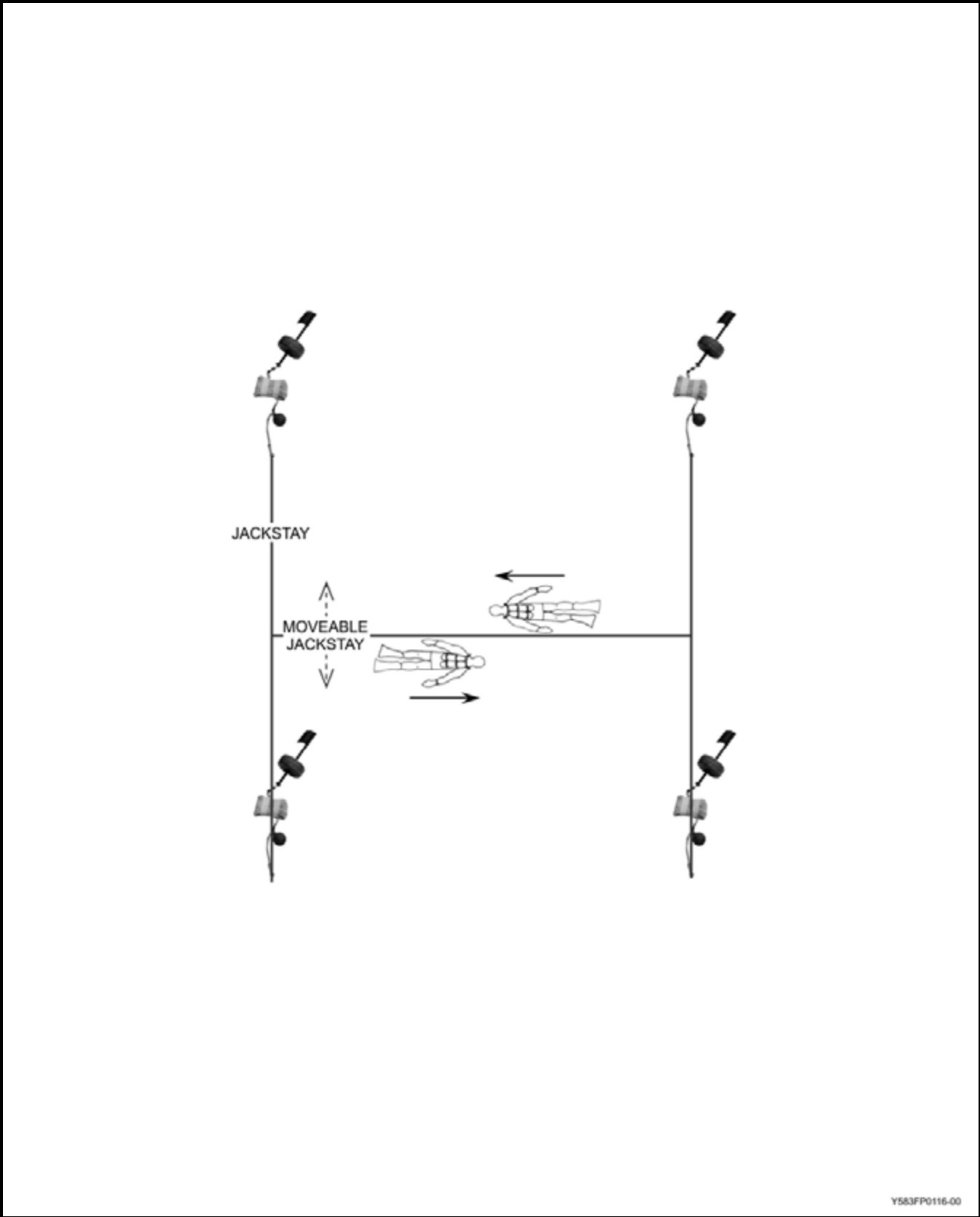

Y583FP0116-00

Figure 5-20 Grid Search

523. MULTIPLE DIVER SEABED SEARCH

1. This type of search also works on a rectilinear basis. It entails the laying of standing jackstays to form the sides of a rectangle.
2. Divers position themselves on a moveable cross-connecting jackstay on the surface between the starting marker buoys or descend to the bottom and space themselves evenly between the two riser shot weights. Spacing may be based on visibility or a snag line method may be used.
3. On a pre-arranged signal from the lead diver the divers commence swimming from one end to the other, keeping abreast.
4. Once the search is completed all divers surface.
5. This search can also be performed under a ship's hull when the laying of a jackstay is not possible. Refer to [Articles 607](#) and [608](#) for techniques and procedures applicable to searching a ship's bottom. These should be reviewed prior to conducting a multiple diver seabed search.
6. The two end divers must ensure they remain on the bottom of the harbour under the appropriate ship being searched.

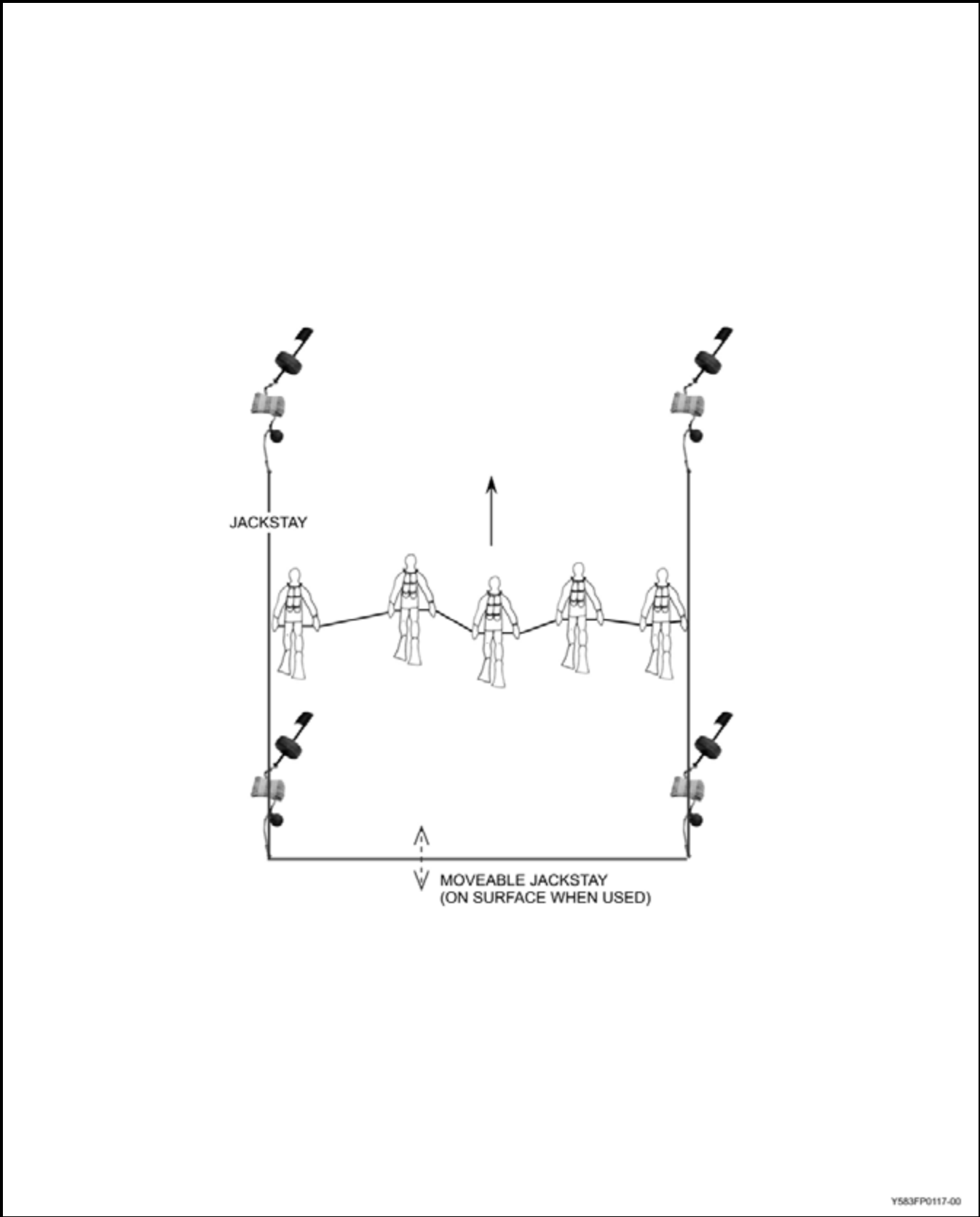

Figure 5-21 Multiple Diver Seabed Search

524. LOST JACKSTAY OR DISTANCE LINE PROCEDURE

1. If the diver loses the distance line in the dark:
 - a. The diver should feel carefully all around before moving away.
 - b. No time should be wasted searching for the line.
 - c. The diver should signal as appropriate to either come up or return to the shot line or some other point where the distance line can be retrieved.
2. If the diver loses the jackstay:
 - a. The diver should search for it at right angles to the direction in which it is laid using the direction of current, stream or bottom features to orient.
 - b. If unsuccessful the diver must return to the surface without wasting further time.

525. HAND-HELD SONAR SEARCH

1. TBP

526. GROUP NAVIGATION CONTROL SYSTEM (GNCS) GROUP SWIMMING

1. GNCS enables a group of divers to reach an objective undetected and at the same time (see [Figure 7-4](#); also refer to [Article 709](#), *Group Navigation Control System (GNCS)*).
 - a. The individuals must be specifically skilled in maintaining a consistent depth.
 - b. The group must conform to the speed of the slowest swimmer.
 - c. The group should be well versed in their established means of communications in order that their movements may be synchronized and so that they are able to react to emergency situations.
2. Prior to commencement of operations or work-up training the following criteria must be met: All members of the diving team must be “proficient divers” IAW [Article 116](#) prior to commencing work-up training on GNCS.
3. During initial work-up training each pair is to complete a minimum of one (1) day GNCS swim and one (1) night GNCS swim on a float line as part of a formed group.
4. Marked swimming can commence when the Supervisor is satisfied that the group is skilled in depth control, is able to maintain a consistent group speed and is able to utilize the established system of communication.
 - a. Marked swimming with GNCS is IAW [Article 124](#).
 - b. The lead pair of divers has the marker float tied off on the navigator’s buddy.
 - c. Marked swimming is to be conducted for a minimum of one (1) day dive, followed by one (1) night dive.
5. Once a group has been worked-up on the GNCS they should not have new members brought in unless the group is retrained. A group is considered worked-up for a period of 60 days without subsequent GNCS training.

6. Authorisation to commence free-swimming utilizing GNCS is IAW [Article 121](#) and should only be considered when a group has met the requirements laid out in that article. Additionally:
- a. The depth of the approach area will NOT exceed 30 msw.
 - b. The planned depth of the dive will NOT exceed 15 msw
7. A complete dress rehearsal with all equipment to be carried shall be conducted within 24-hours of the planned dive. It shall include briefings on EPs, drills and all aspects of the dive.
8. It is each diver's responsibility to maintain the planned depth. In order to do this each diver must be wearing a depth gauge that is easily read in both day and night conditions.
9. During training and exercises the safety staff tending and supervising must be in a vessel that can safely maneuver to the position of a stricken diver while avoiding other members on the GNCS, to effect a recovery in a timely manner.
- a. This boat should never be in excess of 300 metres from the team.
 - b. Two vessels should be employed in all GNCS training, one as a safety platform for the Supervisor and Standby diver and one large enough to dispatch/recover all divers. Both must be on station throughout the dive and under Diving Supervisor's direct control.
10. Surface conditions that effect the dispatching and recovery of divers:
- a. Wave height should not exceed 0.5 metres.
 - b. The current should not exceed a speed of more than 1 m/sec.

UNDERWATER TOOLS AND WORK METHODS

527. U/W LIFTING TOOLS

1. **Lifting Bags.** Special underwater lifting bags are available from military and commercial sources. These bags resemble hot air balloons in shape and are fitted with harnesses for holding diving tanks and shackles for attaching slings or hooks. They usually have air bleed-off valves and/or can vent through the bottom. Their lift capabilities vary according to their displacement.
2. **Improvised Lifting Aids.** A number of items of military equipment can be used to provide lift in the same manner as a lifting bag. Taken down empty (or filled with water), they are attached to the object being raised and then filled with air. In choosing an item for use in lifting, strength is a major consideration. Since lifting power is a function of the weight of water displaced, any lifting aid must be capable of being completely filled with water and safely suspended by its lines in air. The following are ideal lifting aids:
 - a. Kit bags providing up to 100 kg of lift,
 - b. Jerry cans providing up to 20 kg of lift, and
 - c. Oil drums providing up to 200 kg of lift (see [Figure 5-22](#)).

528. U/W LIFTING



Extreme caution shall be exercised by all divers utilizing any air-filled lifting tool.



Both Supervisors and divers must appreciate the danger of the object breaking mud suction and rapidly propelling to the surface — *uncontrolled*. Severe injury can be caused to a diver whose equipment becomes entangled with a lifting aid that has suddenly broken free.

1. Rigging

- a. In order to ensure that objects being recovered are not dropped back into the water when lifted out (e.g. breaking lines or shackles) basic rigging considerations must be applied in all lifting operations.
- b. Most objects weigh considerably more in air than in water. Therefore, rigging calculations should use the weight (W) of the object rather than the lift requirement (L).

2. Air Expansion

- a. If a lifting aid is not completely full when the lift commences the air will expand on the way up. Lift will increase and the rate of ascent will accelerate. This could be dangerous. All lifting aids should have a simple means of being vented.
- b. It is safer to use a number of smaller lifting aids — all completely full when the lift commences — than one large one only partially-filled.
- c. The diver must have an escape route planned and stay clear of all lines during the lift.

3. Suction

- a. If an object has been lying for a long time on a silt or mud bottom a great deal of lifting force will have to be applied in order to break the suction. Application of such force is often difficult and may result in an uncontrolled ascent.
- b. Excess lifting force should not be applied but rather the suction should be broken through the use of a tunnelling lance or dredge whenever possible.

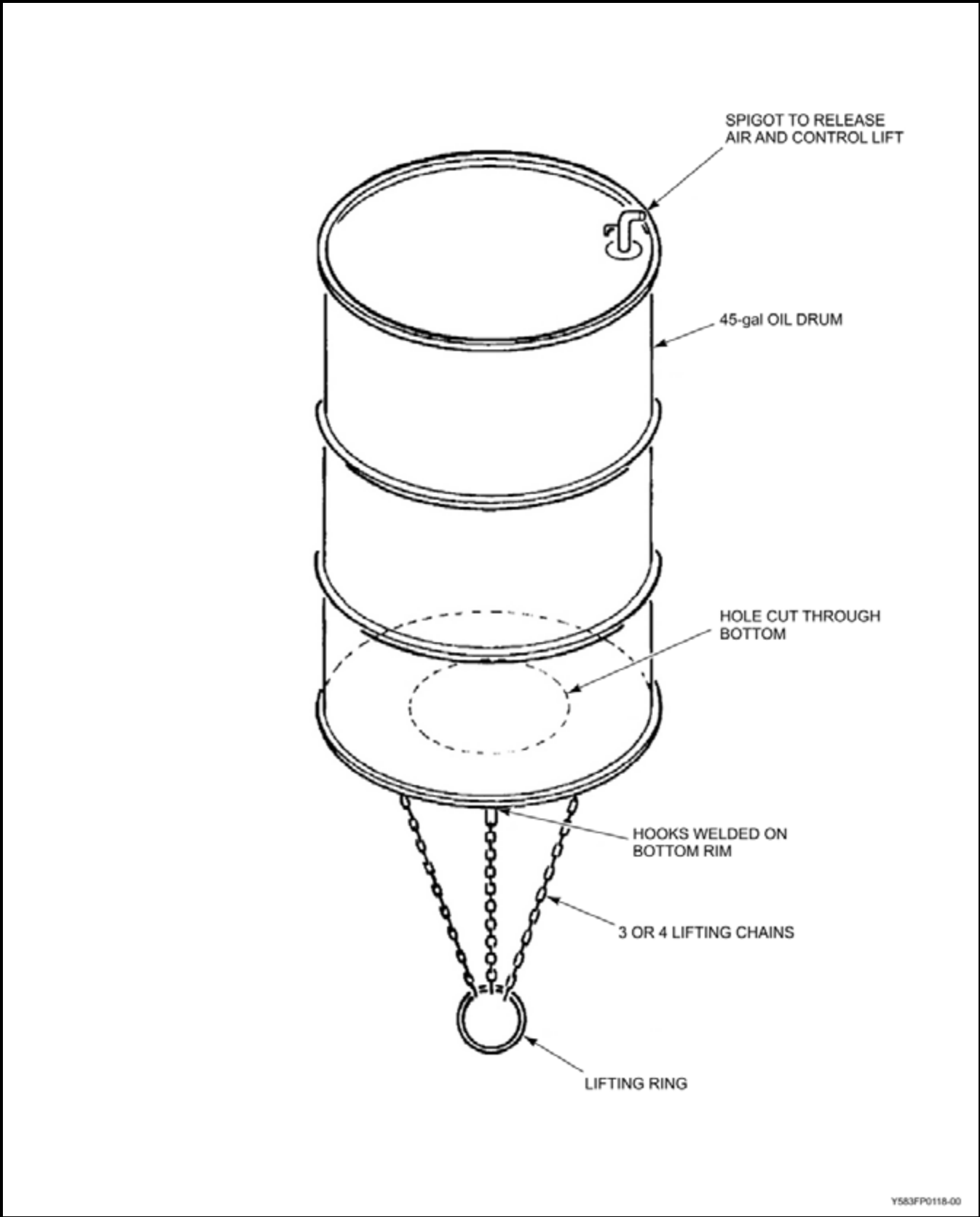

Y583FP0118-00

Figure 5-22 Improvised Lifting Aid Using an Oil Drum

529. U/W CONSTRUCTION

1. **General.** During wartime, one of the major tasks for divers is the construction and placing of underwater obstacles. Other engineering tasks that may require divers in war and peace are the construction and repair of underwater pipelines, power and communication cables, piers, docks, dams, sewer and water systems and other military installations. These generally require no special engineering skills other than those required to construct similar structures on land or above the waterline. Water conditions and the capabilities of the divers set limitations to underwater construction. Construction procedures, equipment and tools required are similar to those used on land.

2. **Construction Methods.** Divers will find a great deal of difficulty in handling building materials underwater. Buoyant materials tend to float away while heavier ones like sand bags or steel are awkward loads to carry. Currents interfere with the placement of large flat materials such as plywood and limited visibility restricts each diver's safe working area. All of these result in a requirement for a high degree of simplicity and over-design in terms of strength and prefabrication in underwater construction.

530. U/W TIMBER AND WOOD CONSTRUCTION

1. **Guidelines.** Wood is the most common U/W building material. The following instructions should be followed when using wood in underwater construction:

- a. All pieces should be pre-cut, pre-bored and clearly marked.
- b. Wood should be properly treated with an appropriate preservative if the structure is to last more than a few years.
- c. The buoyancy of wood may be reduced by leaving it to soak in water overnight before its use (provided any swelling has been accounted for in the design).
- d. Large lag bolts that can be screwed with a ratchet wrench are more suitable for underwater use than nails and/or drift pins that have to be driven by hand.
- e. Wood should be weighted and tethered when being lowered to divers.

NOTE

Neoprene rubber deteriorates quickly when placed in contact with many types of wood preservative. Divers should wear service coveralls over wetsuits when working with this chemical or with preserved wood. Soap and water should be available for washing wetsuits each day. As well, exposure to this chemical could cause mild skin irritation. More severe discomfort can be prevented by ensuring divers do not unnecessarily wear wetsuits when not actually engaged in diving and follow normal hygiene procedures.

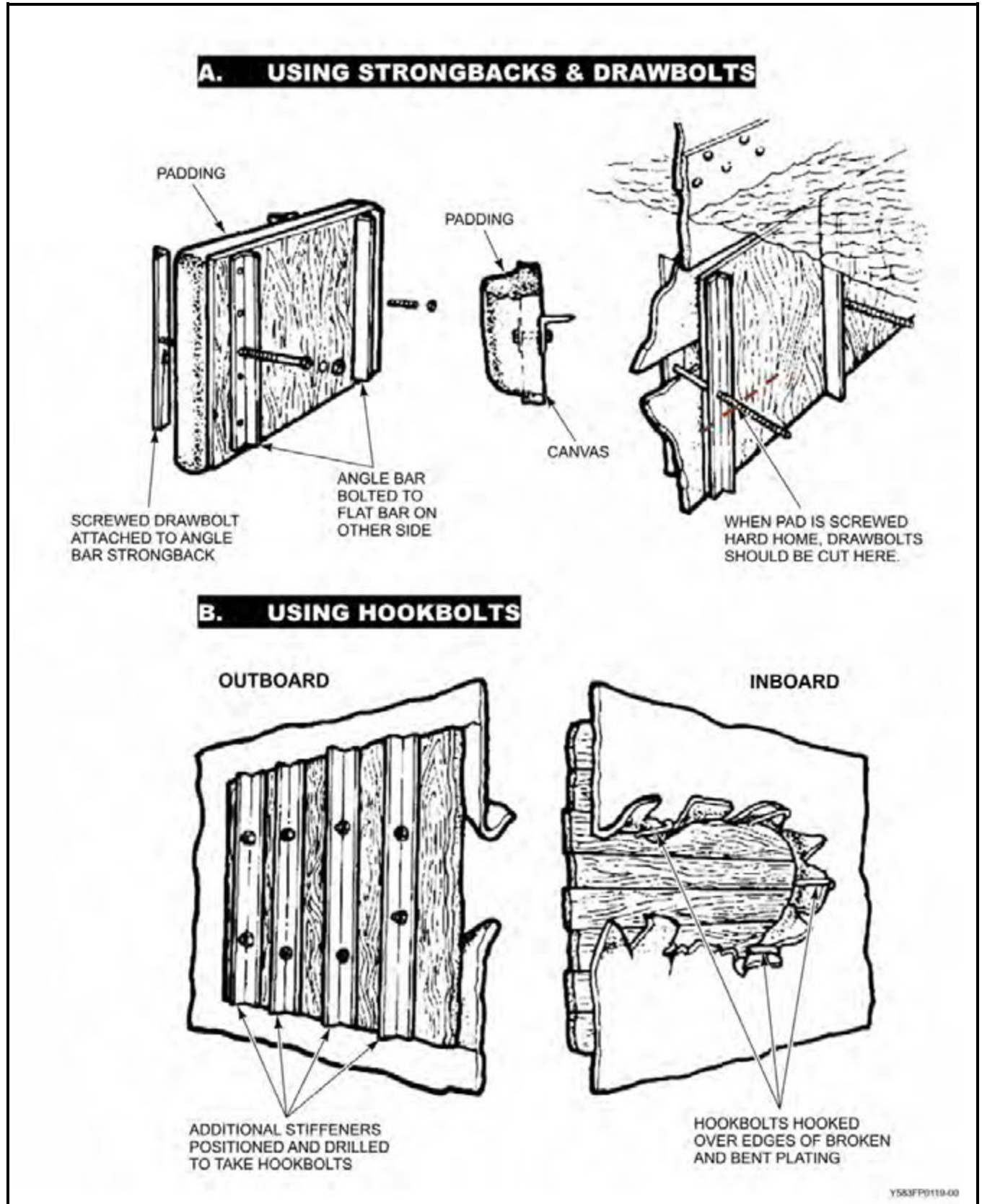

Figure 5-23 Methods of Securing a Timber Patch

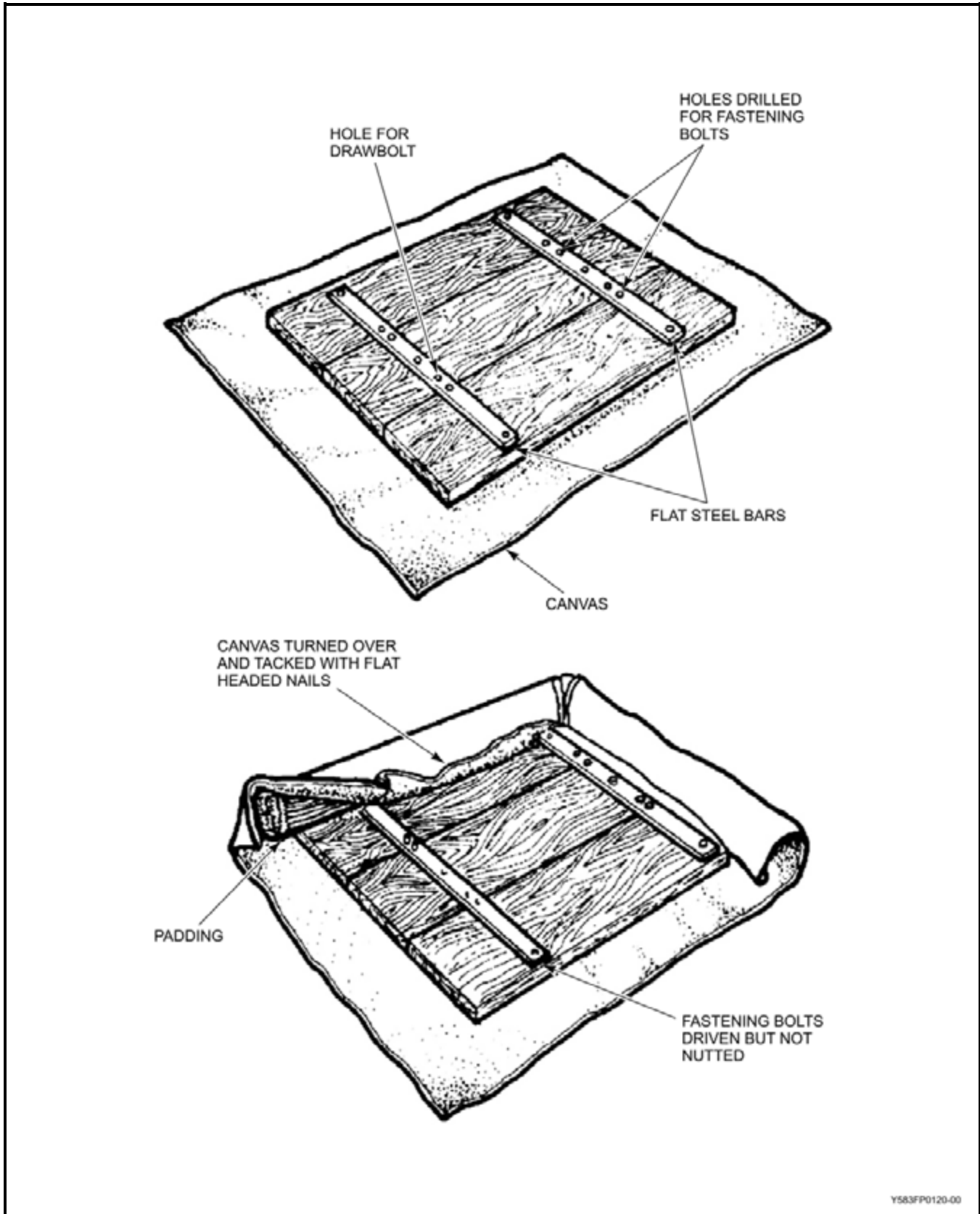

Figure 5-24 Timber Patch

531. REPAIRS TO MILITARY FLOATING EQUIPMENT

1. Temporary Repairs

- a. It may be necessary to make temporary repairs to military vessels, floating bridges or rafts without removing them from the water. There are various types of metal patching kits available that may be used for small patching jobs.
- b. If patching kits are not available improvised patches can be used.

2. Small Holes

- a. Where the hole to be closed is small and the surface of the damaged metal plating is without any undue curvature, a timber patch suitably stiffened with light steel sections to withstand the hydrostatic pressure is most easily and quickly applied.
- b. For small punched holes, long narrow holes or where the plating is thin and the frames widely spaced the most efficient method of securing the patch is by means of drawbolts and angle or channel-bar strongbacks as shown in [Figure 5-23](#).

3. Large Holes

- a. For larger holes where the span is too great to permit the use of strongbacks, hookbolts are used, these being passed through the patch and hooked onto any convenient part of the damaged plating or onto frames, *etc.* as shown in [Figure 5-23](#).
- b. When using hookbolts a template must first be made.
 - (1) Light wooden boards are nailed together in the shape and size of the intended patch and this rough template is lowered and positioned over the damaged area.
 - (2) The diver takes down additional boards and nails them across the template in positions where the hookbolts are to be fitted and marks the positions of the bolts on the boards. The completed template can then also be used to mark off the position of the boltholes on the patch.

4. Timber Patch

- a. The materials used in the construction of timber patches depend largely upon what is available at the time. Tongue and groove planking is most suitable because it provides greater strength (and improves water-tightness, but that is of no great importance as timber patches are always canvas-covered on the pressure side).
- b. The patch should be constructed of material that is at least as strong as the hull material. If the patch is to be secured by strongbacks and drawbolts, the following additional materials will be required and used as illustrated by [Figures 5-23](#) and [5-24](#).
 - (1) Two pieces of flat steel bar of length equal to the width of the patch.
 - (2) Two equal pieces of angle or suitable channel-bar of similar length.
 - (3) Two pieces of angle or channel-bar (to act as strongbacks) fitted with long drawbolts.
 - (4) Sufficient canvas to cover an area approximately 1 metre in excess of the length and width of the patch.
 - (5) A quantity of padding around the edges of the patch.

DIVING IN CONTAMINATED WATER

532. GENERAL

1. There is an ongoing requirement for CAF divers to perform working dives in waters contaminated by a variety of pollutants. These may include pathogenic microbes, toxic or noxious chemicals and nuclear reactor effluents. Because water pollution is common in Canadian harbours and estuaries, and indeed in many of the locations around the globe in which CAF divers are required to operate, all divers should be aware of the hazards associated with contaminated-water diving. They should also be familiar with the necessary pre-and post-dive procedures, equipment requirements and medical surveillance activities required by this type of diving.

2. [Figure 5-25](#), *Table for Assessing the Possibility of Exposure to Contaminants in Dive Site Waters* (3 sheets), provides planning guidelines for assessing the extent of contamination at dive sites.

3. For the purposes of this section, Moderately Contaminated Water (MCW) is defined as: Waters contaminated with pathogenic microbes or chemicals that do not present a documented risk to the diver unless orally or nasally ingested or entering the body by way of cuts, abrasions, or the mucous membranes.

4. The diver can be reasonably protected from this type of contaminant by use of a full facemask and a non-compressible/vulcanised drysuit. Differentiating MCW from non-contaminated water is a complex decision, but a faecal coliform count in excess of that allowed for bathing (swimming) can be considered one criterion.

5. For the purposes of this section, Heavily Contaminated Water (HCW) is defined as: Waters polluted with chemicals, nuclear effluents, biological organisms or other toxic materials requiring complete isolation of the diver, including the skin surface.

6. The additional protection required for this type of diving includes use of a completely dry helmet and extra heavy-duty drysuit with attached drygloves, and extra precautions taken during decontamination.

a. Only Clearance Diving units should be tasked with this type of operation.

b. Procedures for diving in HCW will be promulgated in B-GG-380-000/FP-003, CAF Diving Manual, Vol. 3, *Surface-Supplied Diving Manual*.

7. Research is continuing on the specific hazards and effects on diver safety and health of these occupational exposures and on the development of equipment and procedures to protect divers from such hazards. Individual tolerance to toxins varies widely throughout the population and it is therefore impossible to say with absolute certainty that exposure to a particular microbe or chemical will have no long-term effects on an individual diver.

EXPOSURE TO CONTAMINANTS IN DIVE SITE WATERS			
Typical Locales	Likely Contaminants	Likely Indicators	Likely Symptoms
<ul style="list-style-type: none"> Industrial harbours / ports Great Lakes and the St. Lawrence Seaway System 	<ul style="list-style-type: none"> Sewage Chemicals Metals Hazardous protozoa Bacteria 	<ul style="list-style-type: none"> Dead animals Notable dead marine life, e.g. fish kills, etc. Visible sewage Sewage smell Visible suspicious outfall outflows Heavy slick / sheen on water Chemical smell from water Significant visible floating garbage <hr/> <ul style="list-style-type: none"> Nearby outfalls Nearby heavy industry (e.g. chemical / metal / paper) Heavy algae / slime in water column/on surface Heavy sludge / sediments on bottom (i.e. not natural clays, sands, silts, etc.) 	<ul style="list-style-type: none"> Skin irritation / infection Eye irritation / infection Ear, nose, throat irritation / infection Visual disturbances Digestive system: <ul style="list-style-type: none"> Cramps Nausea Vomiting Diarrhoea Skin blistering / peeling Mental / psychological disturbance
<ul style="list-style-type: none"> Small harbours / ports 	<ul style="list-style-type: none"> Sewage Chemicals 	<ul style="list-style-type: none"> Visible sewage Sewage smell <hr/> <ul style="list-style-type: none"> Nearby outfalls Nearby heavy industry (e.g. chemical / metal / paper) Heavy algae / slime in water column/on surface 	<ul style="list-style-type: none"> Ear, nose, throat irritation / infection Digestive system: <ul style="list-style-type: none"> Cramps Diarrhoea
<ul style="list-style-type: none"> Open seas 	<ul style="list-style-type: none"> Hazardous protozoa 	<ul style="list-style-type: none"> Heavy sludge / sediments disturbed from seabed in water column / on surface <hr/> <ul style="list-style-type: none"> Protozoa blooms on surface (visible films) Protozoa / algae strands in water column 	<ul style="list-style-type: none"> Skin irritation / infection Eye irritation / infection Digestive system: <ul style="list-style-type: none"> Cramps Nausea Vomiting Diarrhoea Mental / psychological disturbance
<ul style="list-style-type: none"> Rivers 	<ul style="list-style-type: none"> Highly variable. from industrial (black water) to pristine. 	<ul style="list-style-type: none"> Ranges from none to all listed under <i>Industrial Harbours</i>. 	<ul style="list-style-type: none"> Ranges from none to all listed under <i>Industrial Harbours</i>.

Y583FP0121-00

Figure 5-25 (Sheet 1 of 3) Table for Assessing the Possibility of Exposure to Contaminants in Dive Site Waters

533. MICROBIAL HAZARDS

1. Microbial pathogens such as bacteria, viruses, parasites, protozoa, fungi, and algae may be naturally present or may be introduced through human/industrial activity such as sewage or chemical wastes from industrial sources, ships or agricultural run-off. In addition, pollutants may “clump” together to form highly concentrated hot spots in an area. According to the U.S. National Oceanic and Atmospheric Administration (NOAA), divers are most likely to be exposed to hazardous contaminants during dives near or on soft bottom sediments. These tend to accumulate contaminants and encourage microbial growth. NOAA states that concentrations of heavy metals such as those associated with waste petroleum products may reduce diversity in a manner that favours pathogenic species. Seasonal variation in Canada also affects the distribution of many species of microbes and divers are generally at greater risk of infection during the summer months. Foreign warm-water locations are also high-risk.

2. Divers working in waters contaminated with harmful microbes may be subject to a variety of maladies, including:

- a. Ear infections,
- b. Eye infections,
- c. Respiratory tract infections,
- d. Inflammation of the intestinal tract,
- e. Warts,
- f. Skin infections,
- g. Central nervous system effects, and
- h. Systemic or pulmonary fungus infections.

3. The best method of protecting divers operating in microbial contaminated waters is to prevent inadvertent ingestion, to reduce skin contact with these organisms and to ensure that divers are adequately decontaminated after completion of each dive. Protective equipment and procedures designed to achieve these goals were tested by the EDU at DRDC (formerly known as DCIEM) and are described below.

534. CHEMICAL HAZARDS

1. Divers operating in waters contaminated by chemicals, many of which are toxic, have experienced upper respiratory tract infections, difficulty in breathing, skin reactions, nausea, burns, severe allergic reactions and tingling of the limbs. Because of delayed onset, it may be difficult to relate cause and effect.

2. Industrial chemicals commonly found in contaminated water include:

- a. Phosphates,
- b. Chlorates,
- c. Peroxides,
- d. Acids,
- e. Solvents (benzene, xylene, toluene), and
- f. Petroleum and petroleum products (the most common chemical hazards encountered by divers).

3. When diving operations in chemically contaminated water are contemplated, the nearest Fleet Diving Unit should be contacted so an adequately protected team can be deployed.

NOTE

Because oil destroys neoprene and rubber, divers should avoid wetsuits or neoprene drysuits when diving in oily water.

535. CONTAMINATED WATER DIVING EQUIPMENT

1. Standard CABA (with a free mouthpiece) offers inadequate protection to divers operating in contaminated water environments. When diving with free mouthpiece CABA, the diver's mouth is directly exposed to the water and the process of inhalation introduces droplets of water into a diver's respiratory tract. CABA divers who are wearing a drysuit and full facemask (FFM) mated to a second-stage regulator can be exposed via skin contact (at the neck, hands, *etc.*), but if the FFM is properly fitted and worn the probability of ingestion is greatly reduced.
2. For Heavily Contaminated Water the skin exposure and small but finite possibility of ingestion associated with hybrid CABA/FFM arrangements requires that the Fleet Diving Units be contacted so an adequately protected team can be deployed.
3. The recommended system consists of a "smooth-skin" drysuit with attached hood and boots. All CAF CABA divers are being outfitted with an upgraded CABA diving ensemble that will provide highly effective protection against MCW. Selected CAF diver categories will in addition retain the standard wetsuit CABA variant mentioned at [paragraph 1](#) for use in clean waters. Because neoprene material acts as a sponge, wetsuits and drysuits made of neoprene are less desirable in contaminated water.
 - a. The suit seams should be sealed by vulcanisation or a similar procedure.
 - b. The number of openings in the suit should be minimised to reduce the number of potential failure points.
 - c. Requiring boots to be attached to the suit permits the number of openings to be reduced to 3 or 4, depending on whether or not the suit is of the neck-entry or shoulder-entry type. The boots should be made of a thick, smooth material that is resistant to abrasion and punctures, have a non-slip sole and be designed to accommodate fins.
 - d. Because gloves are the weakest point in the suit systems used in polluted-water diving, they should be carefully selected with consideration given to compatibility of material with the chemicals likely to be encountered and the resistance of the material to puncture and stress.
 - e. The drysuit hood may have an installed relief valve that automatically vents any air that accumulates in the hood and the skirt surrounding the face must have a smooth outer surface to facilitate sealing with the FFM.
 - f. The FFM should be internally pressurized to prevent the inward leakage of contaminated water. Most models of the AGA FFM have this feature. Divers should make a test dive in clean water to ensure that the mask remains completely dry.
 - g. In pre-dive planning consider that for a given diver the FFM often has a higher rate of air consumption than does standard CABA.

WARNING

When divers are operating on compressed air near spill sites, extra care should be taken to monitor the air intake location to avoid the danger of compressing contaminated air. Similar to the approach indicated in [Figure 5-25](#), the absence of smoke, airborne plumes, chemical or other unusual smell or fumes in the ambient air will generally assure this. If toxic contaminants undetectable to the human senses are suspected, the entire team should be withdrawn from the hazard area.

WARNING

Day/night distress flares should not be used in contaminated waters suspected of containing flammable fumes.

536. MODERATELY CONTAMINATED WATER (MCW) DIVING PROCEDURES AND PRECAUTIONS

1. Divers required to work in contaminated waters must rigorously observe a series of procedures designed to provide maximum protection of the diver and the support crew. In addition to the careful selection of equipment, divers and support crewmembers must be specially trained in the hazards of polluted-water diving.

2. Diving at known contaminated sites such as sewage outfalls, industrial discharges or stagnant pools is to be avoided whenever possible, unless required for operational reasons. Do NOT conduct training dives in these locations unless properly equipped.

3. Consult local authorities such as the Municipal Health Department or Provincial Environment Ministry for information on water quality.

a. Environment Canada also publishes Canadian Water Quality Guidelines (CWQGs):

- (1) Canadian Water Quality Guidelines for the Protection of Aquatic Life,
- (2) Canadian Water Quality Guidelines for the Protection of Agricultural Water Uses,
- (3) Guidelines for Canadian Drinking Water Quality and
- (4) Guidelines for Canadian Recreational Water.

b. If necessary, take water samples and obtain lab analyses.

4. Once these pre-operation preparations have been made and the proper equipment has been assembled the following special precautions should be observed:

a. **Emphasize Dive Site Hygiene**

- (1) All personnel should keep direct contact with contaminated water to a minimum.
- (2) Food should not be consumed while tending divers or handling other equipment that has been in the water.
- (3) Personnel should wash with anti-bacterial soap prior to eating or drinking.
- (4) A "Clean Area" should be designated where personnel can take meals and breaks.

(5) No diving with open cuts or abrasions is permitted. Any skin lesions that occur during the dive must be disinfected and dressed without delay. Although uncommon, certain extremely aggressive microorganisms may enter minor wounds and lead to rapid incapacitation requiring full hospital care. Infection is indicated by rapid deterioration surrounding a minor wound, such as swelling, dramatic colour change, inflammation and rapidly spreading symptoms. Accordingly, every skin lesion must be reported, and carefully monitored at a minimum every few hours for the first 24 hours.

(6) Keep hands away from eyes, ears, nose and mouth.

(7) Snorkels and buoyancy compensator oral inflators should NOT be used.

- b. **Post-dive.** Ensure divers rinse their ear canals with an ear solution such as Vosol, Domboro or aluminium acetate.

5. All divers must receive the full range of inoculations, vaccinations and prophylactic medications IAW the currently approved regimen promulgated by the applicable CAF medical authority. This will generally cover most infectious diseases endemic to the area plus specific prophylaxis against operational risks. Divers handling human remains will be well protected by strict adherence to all the precautions in this section. Other than infection via wounds or contact with mucous membranes, waterborne human remains have not, in and of themselves, proven to be a significant disease transmission vector.

537. POST-DIVE DECONTAMINATION PROCEDURES

1. Both divers and tenders must go through a decontamination process after completing a dive in contaminated water, because evidence shows that divers infected with microbes can contaminate their suits and thus spread infection or re-infect themselves unless the suit is adequately decontaminated. Team members are to wear decontamination protective equipment, up to and including full NBC protective gear if the contaminant justifies it.

2. After each dive the diver is sprayed with a high-pressure sprayer or hose. Three separate spraying solutions maybe used, depending on the contamination.

- a. The first involves a neutralising agent or disinfectant appropriate for the particular contaminant. A one-percent solution of ANTEC®/Dupont® Virkon® S is recommended.
- b. The second consists of a detergent wash-down.
- c. The third and final spray is a freshwater rinse.

3. If contamination is severe heavy-duty brushes can be used to scrub the zippers, mask, boots, boot soles and seams of the suit system. The diver remains effectively encapsulated throughout the procedure and is thus subject to hyperthermia, so there should be no delays during this process.

4. After undressing, the diver should shower with an antibacterial soap as soon as possible. Special attention should be given to ears, hair and beards.

5. The diver's equipment should be attended to by support personnel wearing appropriate protective gear as follows:

- a. Drysuits should be air-dried.
- b. If the suit was flooded the interior should be washed with a one-percent solution of Virkon® S disinfectant, rinsed with fresh water and air-dried. Wetsuits should also be re-washed with Virkon® S solution, rinsed and air-dried.

- c. Boots, gloves, hoods, CABA assemblies and all other diving peripheral equipment such as knives, weights, gauges, fins and facemasks should be soaked in Virkon® S disinfectant for 10 minutes, rinsed and air-dried.
 - d. Buoyancy compensators/life vests should be inflated, immersed in Virkon® S disinfectant for 10 minutes, rinsed and air-dried.
 - e. Work clothing used by surface personnel should be cleaned before stowage.
 - f. Regulators and masks (while still connected to the air source) are to be immersed in one-percent Virkon® S disinfectant for 10 – 15 seconds, rinsed in fresh water, purged three times for approximately 10 seconds, disconnected from the air source and air-dried.
6. Instructions for the proper use of Virkon® S as per manufacturer's direction:
- a. Virkon® S comes in a dry powdered form and needs to be diluted to a one-percent solution for normal use and two-percent solution for severe contamination
 - b. Rebreather counterlungs need to be soaked in one-percent Virkon® S solution for 10 minutes in order to kill all bacterial, viral and fungal organisms
 - c. The equipment then needs to be thoroughly rinsed in fresh water to remove any Virkon® S residue. There is potential that improper rinsing may result in irritation to the lungs or cause long-term equipment damage
 - d. For severely biologically contaminated equipment (e.g. blood, human remains, a suspected disease is present, etc.) a two-percent solution with a soaking time of 30 minutes is recommended.

WARNING

Caution should be exercised when using Virkon® S in its powdered form, as it can cause eye, skin and respiratory irritation. Personnel are to review Material Safety Data Sheet No. 7496 (Virkon) prior to using this material.

538. LONG-TERM MEDICAL PRECAUTIONS

- 1. Divers who work in contaminated waters should advise the DMO of this during their annual medical examination.
- 2. DMO administering these examinations should pay particular attention to the respiratory and gastrointestinal systems and to the ears and skin.
- 3. A diver who may have been exposed to contaminated waters should receive a medical follow-up examination at an appropriate interval post-dive.

ANNEX A5

GUIDELINES FOR SURVIVOR EXTRACTION FROM OVERTURNED VESSELS

A. INTRODUCTION

1. These guidelines were developed from the Search and Rescue Technician's (SAR Tech) *Guidelines for Survivor Extraction from Overturned Vessels* (1 CAD/TRSET Directive 2004).
2. The rescue of survivors from an overturned vessel is likely the most dangerous situation a CAF diver will encounter. Any CAF diving team may be tasked by the Rescue Co-ordination Centre (RCC) to investigate and attempt to rescue survivors of a marine disaster.
3. The rescue of survivors of a marine disaster is best left up to those CAF divers that have been properly trained in survivor extraction techniques *i.e.* Search and Rescue Technicians (SAR Techs) or Clearance Divers (CI Div). Although it is unlikely that a CAF diving team would be tasked to conduct a rescue, this Annex is designed to give the team some basic information that should be considered prior to the attempt.
4. Every situation is different and poses its own set of problems that must be taken into consideration by the team. These procedures are not comprehensive; they do not take into account of all possible hazards and variables. They provide the team with options and a starting procedure. Some modification will be necessary, based on the training and experience of the Supervisor and the team, once they are on location and have surveyed the situation.

B. FACTORS

1. The Commanding Officer, in consultation with the most senior and experienced members of the team must weigh all the known and suspected factors in order to determine the most feasible option for safe execution of the task. Throughout this Annex, reference to decisions made by the Commanding Officer are based upon a ship-borne operation; in the event the team is operating detached from its unit, the officer in tactical command or the on-scene commander will undertake these decisions and considerations.

WARNING

If there is no probability of survivors there is NO justification for entering an unstable OTV in self-contained CABA. Such dives should always be conducted in surface-supplied mode with hard-wire communications, as part of salvage operations.

2. The use of divers will be limited by the estimated submergence survival time of the victims. The decision to use divers in a SAR mode, such as described in this Annex, must be based on a Command decision that there exists a likelihood of survivors remaining entrapped in the vessel. If there is no confidence that any survivors remain, the risks to the divers permitted in this Annex cannot be justified and the vessel should be treated as a salvage operation rather than a rescue. In salvage, all normal rules and procedures described in other Chapters must be followed.

C. EQUIPMENT

1. Due to the likelihood of encountering contaminants from the overturned vessel, the CABA MCW Ensemble with drysuit, FFM and emergency regulator should be worn. (*i.e.* the site is to be considered MODERATELY CONTAMINATED IAW the Table at [Figure 5-25](#)). Not all contaminants in the water will be visible, *e.g.* POLs and battery acid.

2. The stab jacket should include:
 - a. Integral weights,
 - b. Safety knife,
 - c. Whistle,
 - d. Line cutter/scissors,
 - e. Spare dive light,
 - f. Strobe light, and
 - g. Securing lanyards.

PROCEDURES FOR DIVING ON CAPSIZED VESSELS

D. PRE-ARRIVAL

1. Question RCC or persons on scene concerning:
 - a. Vessel's position,
 - b. Number of persons on board,
 - c. Number of persons unaccounted-for,
 - d. Type of vessel,
 - e. Attitude of vessel in the water: upside down, bow up, stern up, *etc.*?
 - f. Cause of capsizing (sea state, collision, taking on water, *etc.*),
 - g. Hull damage,
 - h. Water depth, and
 - i. State of tide or known currents.
2. Request a back-up team from RCC in the following order of preference:
 - a. SAR TECH diving team.
 - b. Coast Guard diving team (West coast, Vancouver Area).
 - c. Clearance diving team.

NOTE

May not be trained in survivor extraction.

- d. RCMP or other police diving team.

NOTE

May not be trained in survivor extraction.

- e. Commercial divers.

NOTE

May not be trained in survivor extraction.

- 3. If a backup team is not immediately available, request re-supply of filled cylinders from the nearest available source. Expect a delay in response time, as most of the above resources do not have immediate access to transportation to the dive site.
- 4. Ensure that VTS (Vessel Traffic Service) demands a "SLOW BELL" (minimum wake from passing vessels).
- 5. Ensure that Coast Guard Radio broadcasts a "REQUEST FOR MINIMUM WAKE" in the area on CHANNEL 16.
- 6. Request salvage bags or large vessels for stabilizing the capsized vessel.
- 7. First unit on scene: DO NOT cut a hole in the hull. Pound on the hull to determine if there are conscious survivors inside and search the surrounding water for any escaped survivors.
- 8. Prepare medical equipment: oxygen, airways, stretchers, bag and mask, electric blankets, advance casualty care equipment, etc.

E. ON SCENE

- 1. Assess site, weather and sea state.
- 2. Determine water depth and confirm state of tide/currents.
- 3. Re-confirm with Command as to whether divers will be committed.
- 4. Assess vessel stability (Refer to [Article "I."](#)).
- 5. Question any survivors as to the number of persons possibly trapped, the vessel layout and where on the vessel missing persons were last seen.
- 6. Attach a marker line to the vessel. This is a marker in the event the vessel sinks.
- 7. **Vessel Slowly Sinking**
 - a. If the vessel is slowly sinking, note where the water line is on the hull. Mark it with a dive knife. Scribe a large arrow pointing down to the scribed water line mark. Check the water line mark frequently.
 - b. If possible, stabilize the vessel with salvage bags or other vessels (refer to [Article "I."](#) for stabilization options).

8. Capsized Vessel

- a. If the vessel is completely capsized but on an even keel it will be very stable, provided that air is not escaping and that it does not have excessive freeboard.
- b. If the vessel is capsized due to collision, check for hull damage where air might escape (refer to [Article "I."](#) for stabilization options).

9. **In Strong Tidal Steams or River Current.** As a general rule, allow the vessel to drift with the current. Do not anchor the vessel, as the divers will then have to contend with a "relative current" and will rapidly exhaust their air supply.

10. **If Conducting Dive Operation From Another Vessel.** Secure it to the capsized vessel if the sea state allows.

- a. Use a light (12 mm) line rigged for self-slipping. A light line is necessary so that if the vessel sinks or the slip line jams the line will break before pulling the diving platform under.
- b. Instruct the crew of the vessel not to allow this line to come under tension.

F. DIVER PREPARATIONS

1. Once on the scene, determine a dive plan and identify a suitable vessel to act as a surface diving platform (if available).

2. When dressing for capsized vessel/confined space operations pay particular attention to eliminating potential fouling hazards in the diver's dress. The diver must be as streamlined as possible.

3. During the dive nothing should be carried in the diver's hands and no gauges or other equipment should be secured to the diver's forearms or wrists. All accessory equipment should be fastened snugly to the diver so that it does not dangle or hang free. All important equipment should be located in the diver's "safety triangle" (triangle formed by diver's chin and the lower corners of the ribcage) so that it can be positively located by feel alone. In particular, the diver's instrumentation (SPG, depth gauge, bottom timer and compass) and the safety knife and line cutter/scissors should be located in this triangle, accessible by either hand.

4. The remainder of the equipment must be secured to the diver or stored in pockets so that hanging gear will not snag during entry/exit of vessel or on other submerged debris.

5. Keep in mind to:

- a. Preserve buoyancy,
- b. Plan an exit, and
- c. Keep the exit clear.

G. ADDITIONAL EQUIPMENT

1. Light system	
2. Small spare diver's light	Secured to stab jacket harness or taped to pressure gauge hose
3. Spare facemask	Used for the survivor(s).
4. Additional diving cylinders and regulators (or FFMs if available)	
5. Safety knife	Attached to stab jacket.
6. Line cutter/scissors	Attached to stab jacket. Used for cutting nets or fishing line.
7. Work gloves	
8. Buoyant lights (Chem-Lites)	Left in survivor's air pocket as a form of reassurance for the survivors. Aids in relocating the air pocket.
9. Strong pry bar	Used for opening jammed doors, hatches, breaking windows, etc.
10. Short lanyards	Used to secure hatches/doors (most door/hatch latches don't work when a vessel is upside down).
11. Strobe light	Used for surface signalling.
12. Whistles	Used for communications should divers become separated at the surface.

Figure 5A-1 Additional Equipment Required for Capsized Vessel/Confined Space Operations

H. DIVING PROCEDURES

Do not use the strobe light inside the vessel. Its use may disorient the divers.

1. Prior to the dive and final safety checks, review signals, dive plan and communications plan with the support vessel.
2. The Supervisor locates to the support vessel and ensures all required equipment is on deck.
3. Develop a communications plan. Select an attendant. Brief the attendant on the use of Standard Tender/Diver Signals and other emergency signals.
4. Divers are to dress for the dive minus the FFM.
5. The diver who will do the initial penetration of the vessel is to be secured to a lifeline.
6. Complete safety checks on all divers.
7. Don the FFM and adjust the fit of the mask.
8. Enter water, reconfirm mask fit and perform diver checks. Depending on the scenario, one diver is to tend the diver about to penetrate the vessel. The diver-tender tends from the water with the same lifeline the surface tender is using.

9. Depending on the situation the Supervisor may elect to initially leave the team on the surface to conserve air. The team enters water upwind/up-current of the vessel if possible and if not, then surface swims to the bow and starts the dive from this location.
10. The divers must note in detail:
 - a. Vessel type and conditions, *i.e.* visibility, lines hanging, hatches, windows open/closed,
 - b. Hull damage,
 - c. Special hazards,
 - d. Air escaping from vessel, *etc.*
 - e. This information will be passed on to the Supervisor and other team members so that they remain updated on changes in any significant factor affecting the situation.
11. The diver gives the capsized vessel an initial quick survey, checking the wheelhouse first. The diver then decides on an entry point and informs the Supervisor, the buddy and the standby diver (refer to [Article "K."](#) for considerations on entry).
12. The diver should then tie back any rigging near the entry point that may get in the way, secure the hatch/door in the open position with lanyard(s) (carried in the stab jacket pockets).
13. The diver-tender tends the diver who is penetrating the vessel, keeping the lifeline clear and ensuring the entry point remains open. Before entry, the penetrating diver should coil some line in hand and pay it out upon entering, to prevent it from chafing against sharp corners.
14. The diver enters the vessel and proceeds either to:
 - a. Last known place of missing persons, or
 - b. The compartment most likely to contain survivors, *e.g.* foc'sle bunks, mess, engine room or space with highest air pocket.
15. The diver is to note what is encountered in case other divers are also required to enter the vessel. It is important to clear the way and tie debris back from the entry point. The diver should frequently signal for any survivor's attention throughout the search.
16. On entering an air pocket containing survivors:
 - a. Release a buoyant light,
 - b. Surface away from the buoyant light and
 - c. Note the number of survivors found.
 - d. It may be an option to secure a secondary line to an object in the air pocket to become a guideline to follow back and forth, if more than one survivor found.
17. Do not remove facemask or regulator to communicate with survivors. Air within the pocket may be contaminated with fuel and/or oil, or oxygen levels may be depleted. Communicate by speaking more loudly than normal, but do not yell through the FFM mask. Reassure survivors, and advise them not to panic. Explain that they are going to be taken out one at a time. Instruct them on how to use the emergency regulator and facemask. Make sure to brief survivors to breathe normally and not hold their breath. Show them how to perform a *Valsalva manoeuvre* if their ears hurt (refer to [Article "M."](#) on preparing survivors for extraction).

18. It cannot be stressed enough that divers are not to remove their own facemask and regulators inside air pockets, as fuel ingestion is probably inevitable.
19. Take out conscious survivors first (“save the saveable”).
20. Follow the lifeline out, protecting the survivor’s head when passing through openings. Watch for signs of panic from survivors, as this will be a terrifying experience for them. Constantly reassure them on the communication circuit if available.
21. If survivors are holding their breath underwater, consider giving them a squeeze before ascending to the surface. This is done to prevent them from surfacing with an air embolism.
22. Upon exiting the vessel with the survivor, the Supervisor determines if the diver has enough air remaining to conduct further extractions of survivors. If the diver’s air is low the divers will change positions and the second diver will penetrate the vessel to extract any remaining survivors.
23. The surface team must be prepared to recover the survivor immediately, and the diver should waste no time at the surface.



No lines are to be attached to the diver when jumping from an elevated platform.

I. ASSESSING VESSEL STABILITY

1. Assess vessel stability as follows:
 - a. **MODERATE to GOOD STABILITY in a Capsized Vessel**
 - (1) Vessel is floating relatively level, both transverse and longitudinally.
 - (2) Hard chine vessels: The hull is immersed between 25 – 60% of its depth amidships
 - (3) Round bilge vessels: The hull is immersed between 25 – 40% of its depth amidships.
 - (4) Hull has several compartments, which will control the rate of flooding, amount of free surface, and degree of loll.
 - (5) Vessel appears “stiff” in the water and is not rolling easily.
 - (6) Hull is beamy (wide) and full form (such as hard chine fishing vessels with deep chines amidships).
 - (7) Capsized vessel has heavy deck gear (*e.g.* big winches, drums, booms, *etc.*).
 - (8) Vessel’s trim and list are remaining steady.
 - b. **LOW STABILITY in a Capsized Vessel, at High Risk of Turning onto its Side**
 - (1) Vessel is floating with a large trim (a sizeable portion of the hull length is immersed).
 - (2) Vessel has a noticeable angle of list (*i.e.* greater than 5°).
 - (3) The hull is floating high in the water (such as a fishing vessel floating mainly on its foc’sle).

- (4) Hard chine vessels: The hull is immersed beyond 60% of its depth.
- (5) Round bilge vessels: The hull is immersed beyond 40% of its depth.
- (6) Given the sea conditions, watch for signs of loll (the vessel is rolling more than expected, caused by excessive free surface movement of trapped water). This is very dangerous and can lead to violent rolling or re-positioning of the vessel.
- (7) The hull is narrow and fine.
- (8) Vessel's heel or trim is changing (indicative of further sinkage).
- (9) Vessel has capsized because of damage to a hull compartment.

2. If a capsized vessel exhibits any of the above factors, secondary stabilization should be seriously considered before a diver enters the hull.

3. During diving operations the following is recommended to help preserve vessel stability:

- a. Heavy items which are hanging below the hull such as a power block on a cable, skiff, anchor, or lead weights hanging from a net, should NOT be cut away, as they may be acting to lower the vessel's centre of gravity, thereby improving stability.
- b. Do not use flotation bags on one side of a vessel to correct a list, unless the list is unquestionably caused by offset weights or asymmetric flooding. Fitting bags to one side can cause an even greater list to the other side when the vessel lolls or lists in that direction.
- c. Never locate flotation bags or attach lifting apparatus below the vessel's centre of gravity, as it will create righting moments that can turn the vessel on its side, spill entrapped air and sink the vessel.
- d. Monitor water depth below vessel frequently. A mast touching bottom can turn the vessel on its side, causing it to sink.
- e. Do not change the trim of a capsized vessel with lifting apparatus, as air may spill from the hull due to change in water plane and cause further sinkage.
- f. Points of entry into the hull should be from the underside as low as possible such as through a wheelhouse window or door. Always enter as vertically as possible into the air pockets. If possible, do not open doors or hatches in transverse bulkheads between compartments, as this may cause further flooding. Maintain hull subdivisions to the greatest extent possible. Close all watertight doors or hatches that are not required for access or escape.
- g. If a large vessel is available and the capsized vessel is in deep water, attach a preventer line to keep the vessel from going to the bottom if it should sink completely.
- h. If possible, plug points from which air is escaping.
- i. DO NOT pierce the hull above or near the waterline, as this will cause air to escape and the vessel will sink further.

J. DISORIENTATION

1. If diver becomes disoriented in the capsized vessel, consider the following:

- a. Turn upside down and "stand" on the deck. This may help in visualising the layout of the vessel and where to go next.
- b. Follow the lifeline out until reoriented. This may be the only option in zero visibility conditions.

K. CAPSIZED VESSEL SINKING

1. The sinking of a capsized vessel may not be apparent to the diver within the vessel. Divers should be aware of changes of pressure in the ears indicating a change in depth. Divers should continually check their depth gauges.
2. The dive tender on the surface must keep an eye on the waterline level of the capsized vessel and inform the divers of any changes.
3. If line signals cannot be used, the diver shall respond to the following:
 - a. AIR ESCAPING RAPIDLY **GET OUT NOW!**
 - b. RAPID CONTINUOUS POUNDING ON HULL **GET OUT NOW!**
4. Divers must disconnect from their lifelines if they are hampered in any way by the line while escaping from the vessel.
5. The second diver is to wait until the diver is out of the vessel. Both divers then ascend together to the surface.

L. ENTANGLEMENT

1. A diver's knife is very poor tool for cutting monofilament line. In addition to the safety knife (a part of the CABA Ensemble), standard working scissors or specially designed line cutters are the most effective tools for this situation. They must be attached to the diver's chest area on the stab jacket for ease of access when tangled.
2. An entangled diver should not struggle, as this often worsens the situation, but should first try to calmly work free and should secondly advise the dive partner.
3. If the anchor point of the line or net is below the diver, the diver should gain a little positive buoyancy in order to tension the line or net before attempting to cut it.
4. If the anchor point is above the diver, the diver should gain a little negative buoyancy.
5. If unable to free, call the second diver or standby diver for assistance. Use 2 – PULLS / 2 – PULLS / 2 – PULLS on the lifeline or, if the diver is within reach, squeeze signal 2–2–2.

M. PREPARING SURVIVORS FOR EXTRACTION

1. A lot can be accomplished to alleviate panic in the survivors when the diver first meets them in the air pocket. A calm, reassuring attitude together with understating their predicament and trying to convince them they have already been rescued will go along way to preparing them for the most difficult part – extraction.
2. Divers should report number and condition of survivors to the surface.
3. A survivor may be:
 - a. Conscious,
 - b. Calm,
 - c. Panicked:
 - (1) Mildly panicked,
 - (2) Severely panicked (aware of surroundings but out of control),

(3) Incoherently panicked (unaware of surroundings),

d. Unconscious.

4. The principal medical complication of the survivors will likely be hypothermia, or fuel oil aspiration or ingestion. The oxygen content of the air pocket may be low or contaminated with gas, oil, dirty bilge fumes, battery acid, *etc.*

5. Communicate to survivors by speaking loudly through the mask. The diver should briefly explain how to hold the emergency regulator in the mouth and how to purge it.



Ensure that the survivor's facemask is sealed and does not flood. Ensure the survivor knows that if the mask floods it is still possible to breathe via the mouth, otherwise the survivor may inhale water through the nose.

6. On the first survivor to be extracted, the diver fits the spare facemask and places the regulator in the survivor's mouth and then together they proceed out. The diver should reassure the survivor all the way.

7. Unconscious, breathing survivors in an air pocket should be removed last. The diver will have to assist the survivor with breathing by depressing the purge button on the emergency regulator.

8. The priority is the conscious survivors in an air pocket. If submerged drowned victims are encountered along the way, they may be passed out to the second diver if expedient.

9. If unable to extract survivors and if available, consider using SCOTT Air-Pak®, Genesis or Flynn oxygen tanks to increase the amount of oxygen in the survivor's air pocket. SCOTT Air-Pak® tanks may be borrowed from nearby vessels or ferries. Use air from the diver's cylinders only if there is enough for the diver to complete the operation.

N. SURVIVOR PANIC

1. When there is a survivor panicking in an air pocket, take out the stable survivor(s) first. Reassure remaining survivors. A full explanation may help, or consider bringing in the second diver to assist in the extraction.

2. If a survivor panics during the extraction, use lifeguard techniques. The best position to be in is behind and slightly below the survivor, to protect the diver's mask and regulator.

3. When pulling the survivor from the vessel, the surface team must be ready to assist.

O. OTHER CONSIDERATIONS

1. Diving in Zero Visibility

a. In zero visibility conditions, proper site evaluation and history of the incident will provide the ability to ascertain whether to dive or not.

b. Zero visibility diving should only be attempted when the Supervisor, in consultation with the Commanding Officer, has determined that the risk is acceptable using parameters including but not limited to:

(1) Fishnets,

(2) Drifting debris (*e.g.* ice, logs, partially buoyant vehicles, *etc.*),

- (3) Currents IAW those stated in [Figure 5-8](#),
 - (4) The diver's ability to cope with the situation,
 - (5) Depth,
 - (6) History of the case (possible suicide),
 - (7) Log booms and
 - (8) Vessel traffic encountered.
- c. Standard line hand signals should be utilized in zero visibility. Hard-line voice communications is the preferred method if available.

2. **Night Diving Operations**

- a. Night diving operations present the diver with more stress and anxiety than encountered in a similar daylight environment. Managing this stress when it's experienced is essential to safe and effective night operations.
- b. With the exception of additional lighting, night diving dress does not vary from standard CABA diver dress. However, due to the reduced visibility it is important to ensure that alternate air sources are clearly identifiable.
- c. The emergency regulator should be positioned in the diver's "safety triangle".
- d. All instrumentation, *i.e.* compass, timer, depth gauge and pressure gauge will be luminous/illuminated for easy reading.
- e. A whistle should be attached to the divers stab jacket for redundant surface communications in the event of diver separation and/or communication equipment failure on the surface.
- f. Each diver should carry a securely fastened backup dive light.
- g. Chemical light sticks are useful in night diving operations. They can be used for marking ascent/decend lines, a diver's position, entrances to confined space, *etc.*
- h. The use of voice communicating systems will alleviate the tendency for the diver to feel alone. However, through-water communications are not available to all CAF diving teams.

3. **Reference Line Ascent and Descent.** During diving in zero visibility or during night diving operations, visual references for diver orientation may be difficult to maintain in the limited lighting offered by the diver's light. For this reason and when operations permit, descent and ascent should be conducted with the aid of a "reference line". Anchor lines or lines from marker buoys are well suited for this purpose and will be available aboard most surface support vessels.

4. **Dive Site Illumination**

- a. Dive site illumination (for depths 0 – 12 msw) may be effectively enhanced by having surface vessels direct their searchlights onto the surface.
- b. When surface lighting is in use surfacing divers must shield their eyes.
- c. Both surface lighting and divers' lights will attract underwater organisms to the area of the diving operation. These will generally be non-harmful "schooling" -type fish and marine mammals. Left alone, they should not interfere with diving activity.

5. **Communications System Failure**

- a. If the communications system fails and where no voice alternative exists, the first step is to attract the attention of the second diver.

WARNING

DO **NOT** USE DIVER SIGNAL RECALLS. Large amounts of fuel may be in the immediate area of the capsized vessel that could ignite if a diver recall was to be used.

- (1) Standard hand signals may be used by shining the dive light on the diver's signalling hand.
- (2) Rapping on a tank or waving a light slowly up and down are attention-getting signals.
- (3) The light may be used for signalling.
 - (a) Making a large circle or illuminating the diver's head means "ALL IS OK."
 - (b) Waving rapidly from side-to-side means "HELP – DISTRESS."
- (4) At the surface a whistle can be used to attract attention.

ANNEX B5**ICE DIVING – STANDARD OPERATING PROCEDURES – CABA/LWSSDE****SECTION 1****GENERAL**

1. Ice diving is a specialized form of diving that introduces several additional hazards such as equipment freeze-up, entrapment and hypothermia. However, divers properly trained and experienced in under-ice and cold weather diving have an extremely low accident rate. Situations regularly arise in which it is necessary to dive beneath ice for reconnaissance, EOD operations, or recovery of personnel, vehicles or equipment that have fallen through the ice. Ice diving operations may be required in any of the inland waters of Canada as well as the Arctic Ocean. Although the actual diving techniques are not very different, certain planning factors, equipment and safety precautions must be kept in mind during ice diving operations. The Diving Supervisor must also remember that while each item increases the diving teams' effectiveness, it adds to the overall weight for transport, thereby decreasing the portability of the ice diving package. In addition, all personnel must adequately prepared for and briefed on of the signs, symptoms and prevention of cold stress, hypothermia, frostbite and snow blindness (also refer to [Article 143](#) and see [Figures 1-7](#) and [1-8](#)).
2. Some procedures in this chapter may not be practical in operational situations but the basics/safety related equipment remains the same. Since many operational ice dives have been conducted for aircraft crash investigation, additional hazards from fuel, jagged metal, human remains and explosives/pyrotechnics may need to be planned for. Only Clearance Diving teams are trained in safe removal of aircraft explosives and pyrotechnics.
3. The preferred breathing apparatus employed to conduct ice diving is LWSSDE. However, if LWSSDE is not available, ice diving may be conducted using CABA configured for ice diving as promulgated at this article (refer to [Section 2, Paragraph 10.](#)).

SECTION 2

PROCEDURES

1. **Diving Supervisor Considerations During Initial Dive Planning**
 - a. **Ice Thickness.** Minimum 15 cm – varying types, provided at least 7.5 cm of the required 15 cm is clear ice. If thickness is unknown then personnel testing the ice shall wear a floater suit/drysuit and must have a lifeline securely attached.
 - b. **Wind Speed and Direction.** Determine wind chill IAW [Figure 1-8](#), *Wind Chill Chart* or Environment Canada *ChillDex/FroiDex* chart.
 - c. Water and air temperatures
 - d. Tides or current
 - e. Nearest RCC, hospital, ambulance, doctor and phone
 - f. Maximum depth of water (utilizing sounder/marked line once a small hole is cut using ice auger/chainsaw)
 - g. Equipment is free of moisture. Life support equipment is prone to failure when moisture is present in components
 - h. Underwater obstructions/hazards/bottom type/visibility
 - i. Altitude (detailed topographical maps or altimeter can be used)
 - j. Distance over terrain to be traversed to/from support vehicles/shore site.
2. **Dive Site Preparations**
 - a. The unloading process begins after a determination of requirements and type of equipment to be utilized, and confirmation that ice thickness is sufficient to permit the diving operation to be safely conducted.
 - b. Equipment should be offloaded in a clear area /tarpaulin or canvass, to prevent the loss or damage of gear in the snow. Cleared paths, for access to the dive site must be made, utilizing shovels, snow blowers or snowmobiles. Hand-carrying equipment should be avoided; the use of sleds to transfer equipment over soft uneven terrain is preferred.
 - c. At the dive site, a hole is cut to confirm ice thickness, depth of water and current. This hole can be used to start cutting the diving hole. One person stands at the proposed hole site, holding one end of the diver's lifeline, and another person walks a path circumscribing 360 degrees around the site. Once that is done, the circle is cleared out 0.5 – 1.0 m wide and divided into six equal parts by clearing paths (spokes) 0.5 m wide from the centre to the outer ring. The work area, approximately 10 m in diameter, is then cleared in the centre where the spokes meet, making a wagon-wheel pattern. The wagon-wheel pattern allows light to pass through and serves as a visual underwater highway and guide for the divers to navigate safely back to the entry hole. See [Figure 5B-1](#).

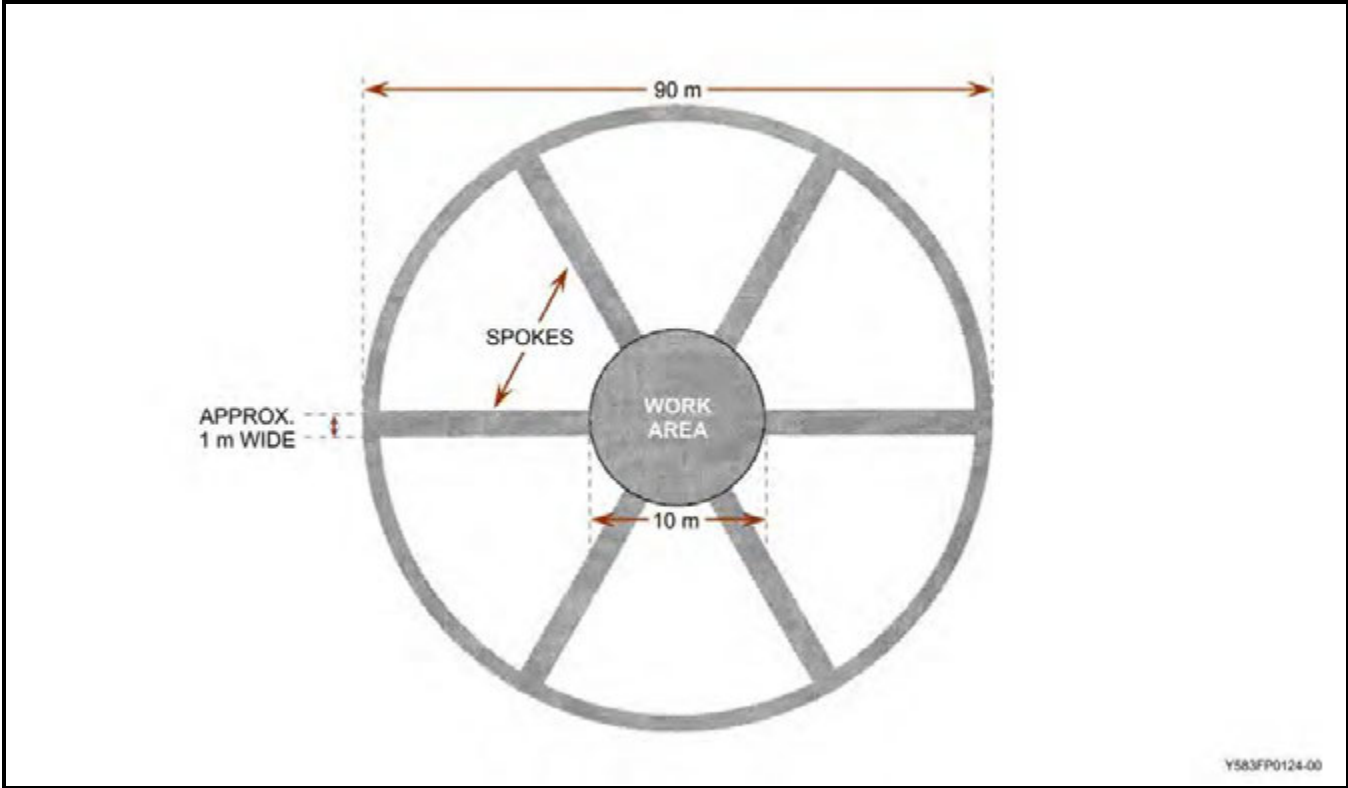

Figure 5B-1 Ice Diving Site

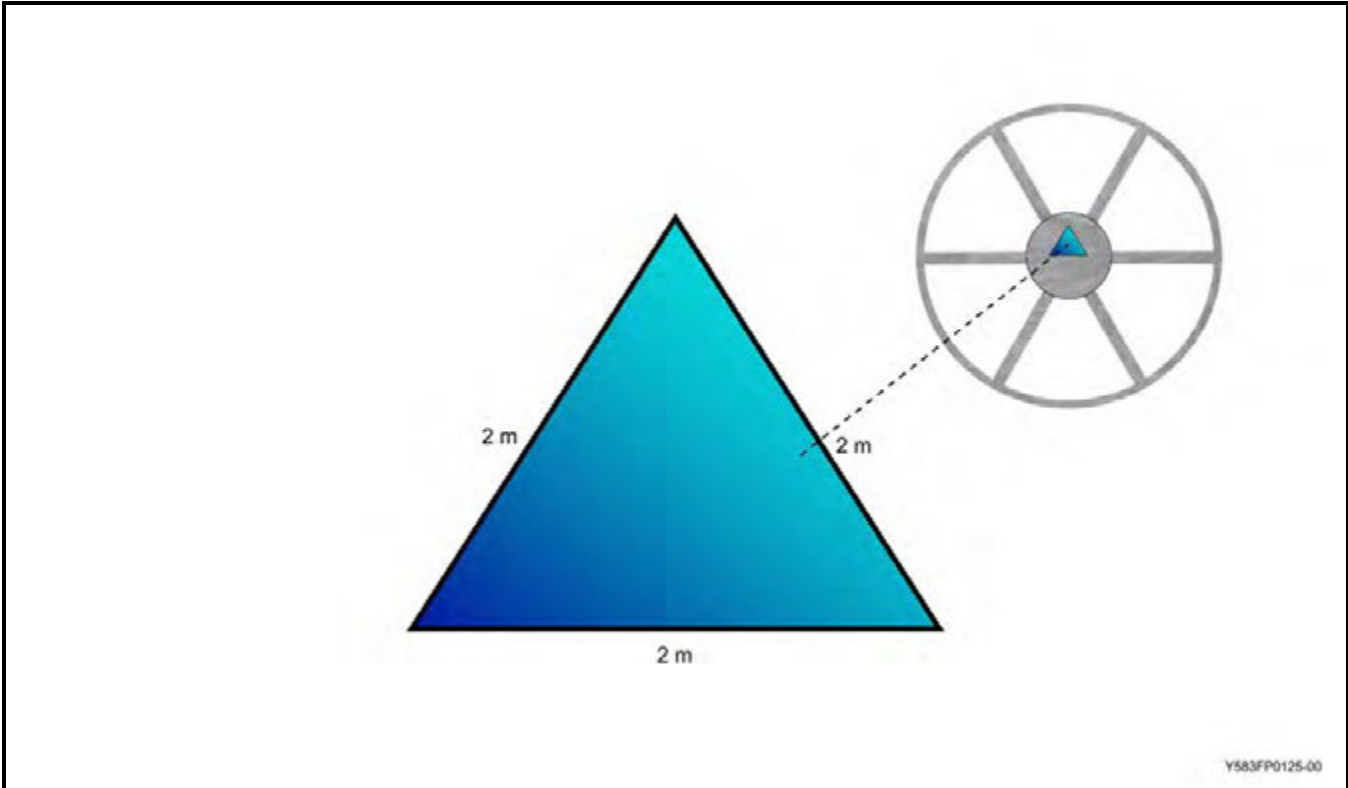
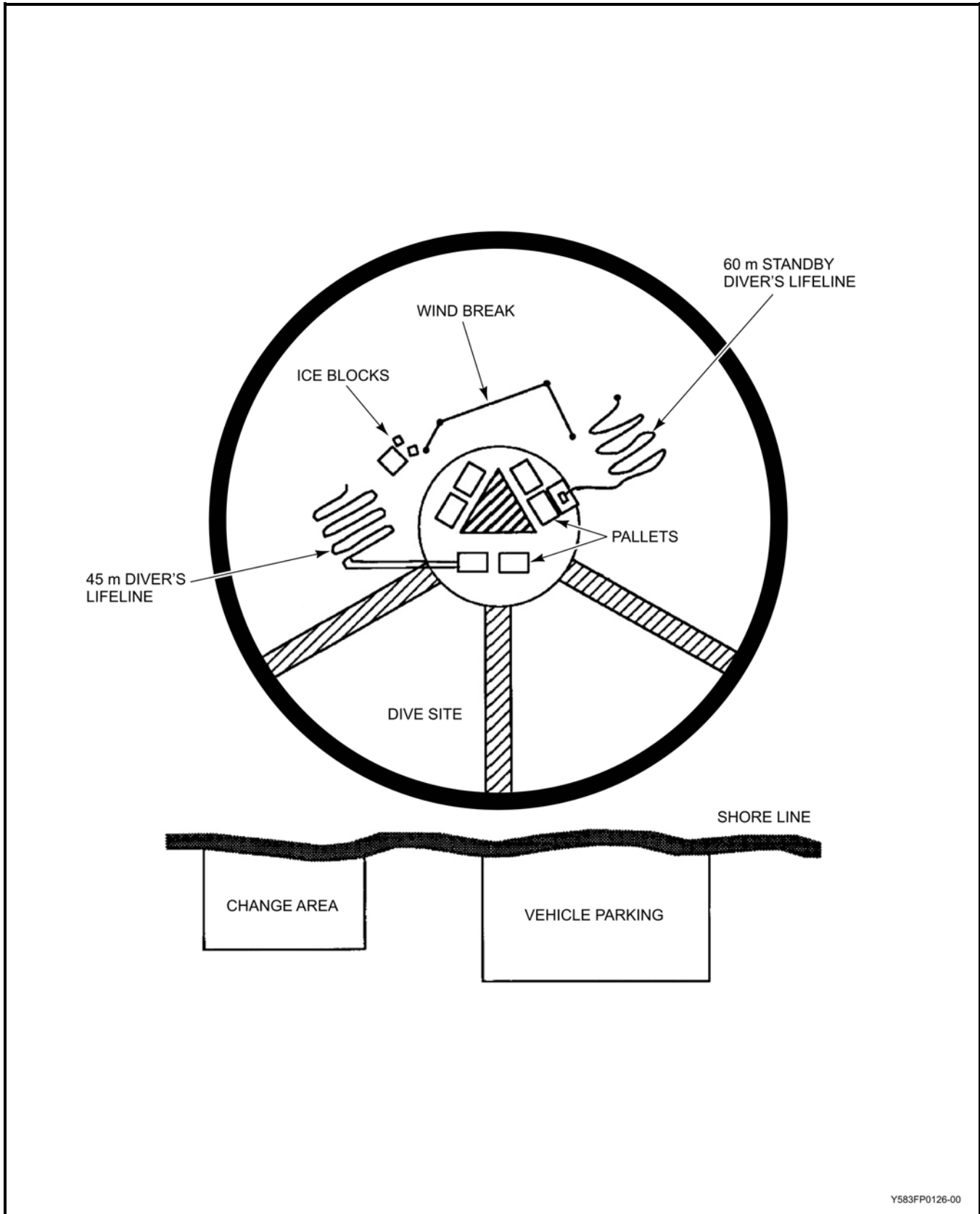

Figure 5B-2 Ice Diving Hole



Y583FP0126-00

Figure 5B-3 Dive Set-up, Ice Diving

3. **Entrance/Exit Hole**

- a. The hole is cut in a triangular shape with approximately 2-metre sides. This shape allows easier access in and out of the water by the divers (see [Figure 5B-2, Ice Dive Hole](#)).
- b. All ice blocks must be removed and placed on the ice surface on the edges of the cleared dive site area (can be used to weight the edges of modular tentage). Ice blocks shall not be pushed under the ice surface for three reasons:
 - (1) The blocks will be present as an unnecessary obstruction underwater, fouling the divers lifeline,
 - (2) They could slide back up into the hole blocking the diver's exit, and
 - (3) For safety of others, the ice blocks must be replaced in the hole after the diving is completed.
- c. Place two pallets or rubber matting on each side of the hole, 0.3 m from the edge and place the seventh close by with the standby diver's bench/seat on it. More pallets/rubber matting may be required if flooding around the hole is expected. A hole that is located in relatively thin ice will erode, due to the exhaust bubbles eroding the edges of the ice access hole. If diving operations must be conducted when operating over suspect or deteriorated ice, an inflatable boat or pallet dock system should be available as a safety platform for Diving Attendants and equipment.

4. **Wind Break/Tentage**

- a. A windbreak upwind of the entry/exit hole for the surface crew, especially the standby diver, is very important. Ice screws or steel pegs should be used as required. If it is possible to erect tentage over the entrance hole or at minimum half modules on the windward side, it will make for a much more habitable work site.
- b. One of the few disadvantages to the use of tentage over the entrance hole is the restriction placed on personnel/attendants within the vicinity of the work area. A heated shelter (tentage, dive truck or trailer) should be placed at or as near as possible to the dive site to protect divers/personnel from the elements.

5. **Use of Small Vehicles.** Although small vehicles (e.g. ATVs or snowmobiles) may be used for haulage and station set-up, they should not be left unattended on the ice. See [Figure 5B-3](#).

6. **Emergency Exit Holes.** In some cases, additional holes should be cut through the ice, around the entrance hole, to provide possible emergency escape or to aid in the dispersion of exhaust from the divers. These holes become very important when the ice is layered due to differences in freezing. In a river, the extra holes are needed downstream only. Except in the case of ice diving, emergency exit holes are normally only used in initial training or during the lost diver drill explained in Emergency Procedures (refer to [Article 223, Lost Diver](#), and see [Figure 2-1, Diving Emergency Procedures – Lost Communication or Lost Diver](#)).

7. **Under-Ice Navigation**

- a. Navigation can be maintained as if conducting normal CABA ops with particular attention paid to the lifeline and umbilical for direction back to the entrance/exit hole.
- b. A weighted shot line may be hung through the hole to aid in ascent and descent.
- c. It may be helpful to suspend a light above or below the surface when tentage is utilized over the work area to help indicate the surface.
- d. When the work or u/w target is located, a distance line should be laid from the shot to the work.

8. Divers' Lifelines

- a. The diver's lifeline is to be configured in accordance with [Article 124](#).
 - (1) At the diver's end a locking Carabiner (2500kg SWL) is secured with a bowline and two half-hitches or a back-spliced hard or soft eye (minimum 5 tucks).
 - (2) The Carabiner shall be secured to the diver's lifeline harness (NSN 4240-20-001-2771) "D"-ring.
- b. The surface end of the lifeline is affixed in the ice with an ice screw adjacent to the entrance/exit hole or, if ice screws are not available, by boring a hole approximately 150 mm in diameter about 6 meters from the diving hole (due to flooding). The lifeline may be secured through the hole with a 60 cm x 10 cm x 10 cm piece of wood, shoved down through the augured hole to act as an anchor. Use a second piece of wood above the ice to keep the block tightly in place.
- c. Fake the line out on the ice for ready use or maintain within a suitable storage arrangement.
- d. Follow the same procedure for the standby diver's lifeline. The standby diver's lifeline is to be a different colour and 15 m longer than the diver's lifeline, as described at [Article 124](#) and [Figure 1-2](#).

9. **Ice Diving Buddy Line.** The normal CABA buddy line (NSN 4220-21-913-2503) described at [Article 125](#) shall not be used. The Ice Diving CABA Buddy Line is to be constructed of the same material of as the lifeline, and configured as follows:

- a. Diver attachment is by the use of two locking Carabiners (2500 kg SWL), one located at either end of the buddy line.
- b. The connecting line will be no less than 4 mm diameter, 2 to 4 metres in length, using a bowline and two half-hitches to provide a soft eye for each Carabiner. Alternatively, a hard or soft eye back-spliced to each carabineer with no less than 5 tucks (or 15 cm if using synthetic line) may also be used at either end.
- c. The buddy line shall be secured to the diver's harness (NSN 4240-20-001-2771), so not as to interfere with the diver's lifeline or the diver's equipment. The buddy line shall lead off from the lead diver's left side.

NOTE

If both divers are utilizing LWSSDE, the buddy line is used at the Diving Supervisor's discretion.

10. Diver Configuration

- a. LWSSDE is the preferred method of conducting ice diving operations. This ensures a standardized configuration for ice diving, an increased air supply, and increased safety through the use of hardwire communications.
- b. If LWSSDE is not available, CABA may be used in the following configuration:
 - (1) Two single 2265-litre cylinders mounted on the BDCMVBC using the double adapter block and two double cylinder bands.
 - (2) Each cylinder shall be fitted with a "J"-valve. The "J"-valve shall be cycled in the **down** position prior to commencing the dive.
 - (3) The diver's right cylinder is designated as the emergency air supply and shall be fitted with a first-stage regulator leading to a side block assembly (SBA) on the diver's right side, and an octopus second-stage (see [Figure 5B-5](#)). A mini gauge (see [Figure 5B-4](#)) shall be fitted to the 1st-stage regulator of the emergency air supply.

- (4) The diver's left cylinder is the primary air supply. It shall also be fitted with a first-stage regulator leading to the side block assembly (see [Figure 5B-7](#)).
- (5) The alternate (octopus) second-stage regulator is to be marked with high visibility tape placed on the intermediate pressure hose where the hose connects to the inlet fitting of the second-stage. This is to ensure that the regulator is not inadvertently used by the diver, preserving the air supply for an emergency (see [Figure 5B-8](#)). The use of bungee cord or surgical tubing to keep the alternate second-stage within the diver's "safety triangle" is permitted.

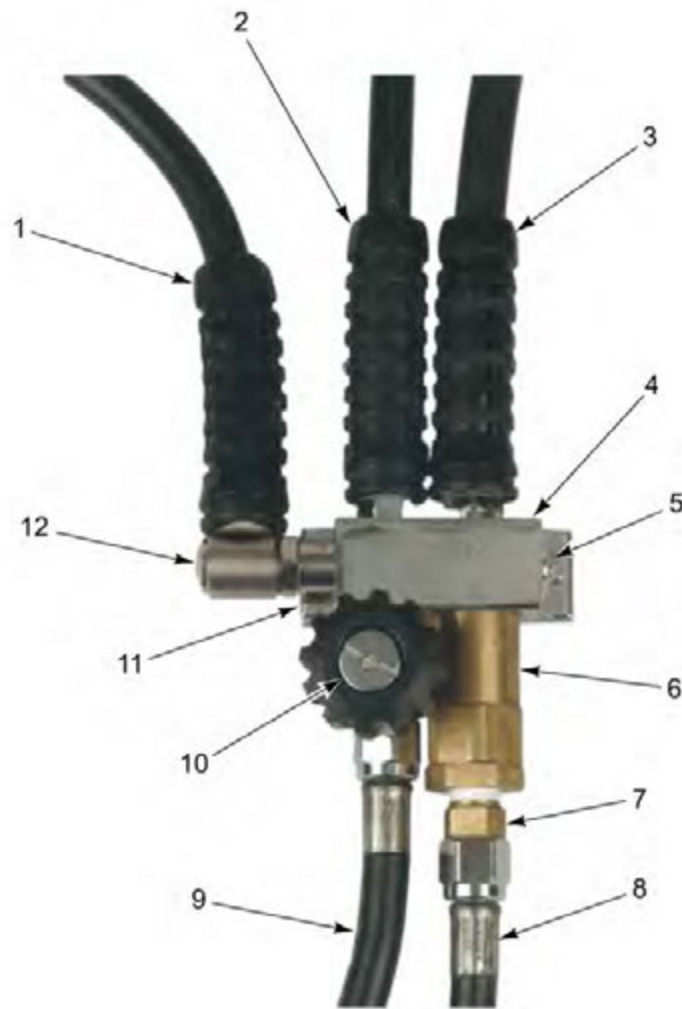

Figure 5B-4 Two Single 2265-Litre (80-Cubic Foot) Cylinders Rigged for CABA Ice Diving with Mini Gauge



Y583FP0125-00

Figure 5B-5 CABA Ice Diving Configuration



LEGEND

1. Suit Inflation Hose 33 in.
2. BC Power Inflator Hose 33 in.
3. IP Hose 30 in. (1/2 in. Hose for the AGA Full Face Mask)
4. Side Block Assembly
5. 3/8 in. Blanking Plug
6. One Way Valve Assembly
7. Scuba Adapter (1/4 in. MNPT to 9/16 in. Scuba Fitting)
8. IP Hose 39 in.
9. IP Hose 39 in.
10. Emergency Valve Assembly (Kirby Morgan)
11. Adapter, 3/8 in. M to 3/8 in. F, 5/8 in. long
12. 3/8 in. Male, 90° Elbow to 3/8 in. Female

Y583FP0129-00

Figure 5B-6 CABA Ice Diving Side Block Assembly

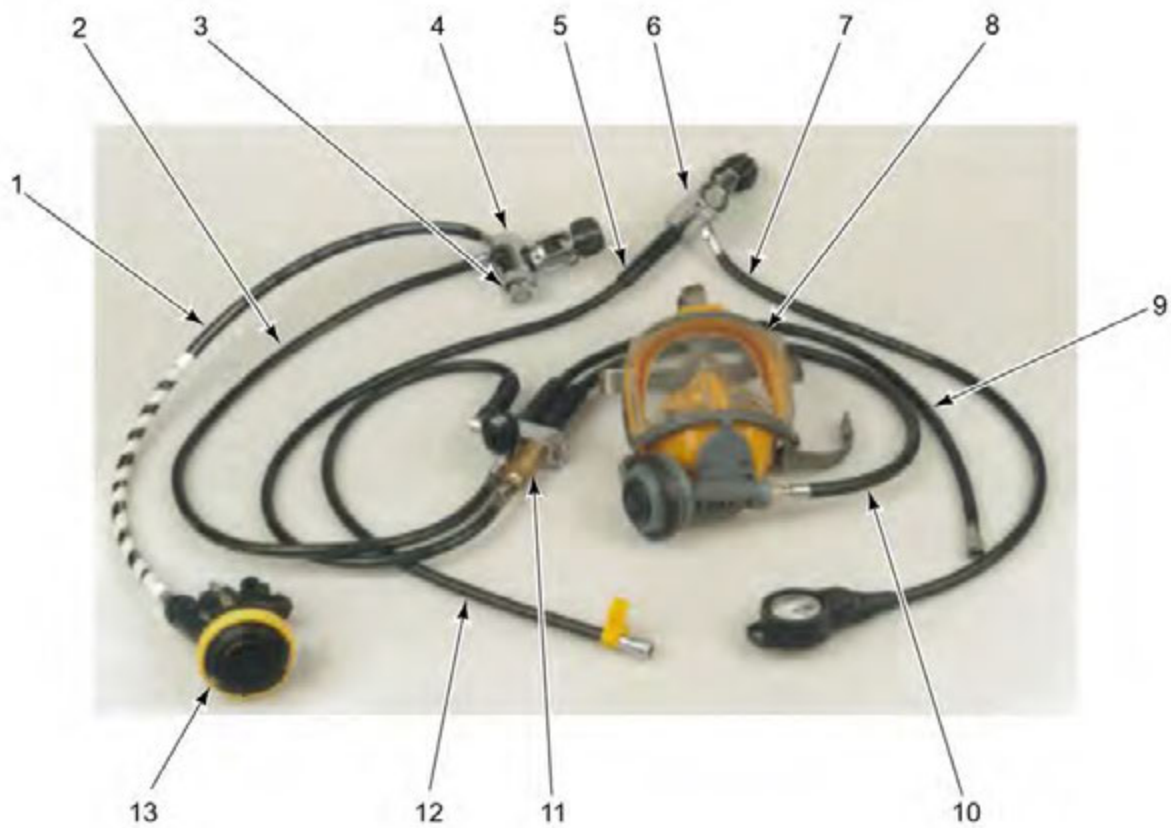

LEGEND

- 1. AGA Octopus Hose 39 in.
- 2. IP Hose 39 in.
- 3. Mini Gauge (SPG)
- 4. Emergency 1st Stage APEKS DST Regulator
- 5. IP Hose 39 in.
- 6. Primary 1st Stage APEKS DST Regulator
- 7. SPG (metric)
- 8. AGA FFM
- 9. BC Power Inflator Hose 33 in.
- 10. IP Hose 30 in. (1/2 in. Hose for the AGA Full Face Mask)
- 11. Side Block Assembly (Figure 5B-6)
- 12. Suit Inflation Hose 33 in.
- 13. AGA Hybrid Octopus 2nd Stage Regulator

Y583FP0130-00

Figure 5B-7 CABA Ice Diving Side Block Assembly



Y583FP0131-00

Figure 5B-8 Example of Octopus Regulator Marked for Ice Diving

- (6) A strobe light and indicator light shall be worn by all divers. The divers are to turn it on and check its operation prior to diving. Should an emergency occur, the diver shall activate the strobe light. This action will permit easier detection of the diver(s). The use of a day/night distress flare is of little value and not required in ice diving.
- (7) Each diver should carry an ice screw in addition to both dive knives. In the event the diver becomes disconnected from the lifeline, the ice screw will provide a more secure anchor while waiting for the arrival of the Standby Diver.
- (8) The divers shall use a BDCMV buoyancy compensator.

11. **Divers**

- a. Ice diving operations are normally conducted in pairs. One diver is assigned as the “Lead Diver”.
- b. The diver(s) and the standby diver are to normally dress in sheltered areas, and when ready, proceed with their attendant(s) to the dive site. Divers should be burdened with only the minimum equipment while walking over snow/ice terrain. Sled/snowmobile or support personnel can transport their equipment.
- c. Diver(s) secure their own lifelines with Carabiners IAW [paragraph 8](#) of this Section, “Divers’ Lifelines”.
- d. The Supervisor must conduct surface checks of all divers prior to anyone entering the water. Divers shall demonstrate clear knowledge of the location of the dive equipment (e.g. side block, suit inflation, alternate octopus second-stage).
- e. Attendants should leak check all HP/LP fittings with cold temperature leak detector. If this is not possible, the divers will conduct a leak check under the direct supervision of the Supervisor immediately upon entering the water.

12. **Standby Diver**

- a. The standby diver shall be at *Immediate Notice*.
- b. Do NOT conduct in-water leak check with standby diver, as equipment will freeze.
- c. The standby diver must be capable of providing an alternate breathing source to a stricken diver regardless of the breathing apparatus in use.
- d. Diving Supervisors should never allow a diver that has been in the water to continue as standby diver after a dive. Always allow divers to fully re-warm before taking over the duties of the standby diver or attendant.

NOTE

If utilizing LWSSDE for the standby diver it shall be configured from a *second* LWSSDE panel due to the need for a different over-bottom pressure setting.

13. **Attendant(s)**

- a. Attendant(s) shall be dressed warmly and with flotation.

NOTE

Attendants and surface crew working close to the hole shall wear flotation devices/clothing. Use of “ice stud” slip-on footwear should be considered.

- b. When diver(s) have left the surface, the attendant(s) shall maintain positive control of the lifeline by:
 - (1) Standing at the opposite side of the hole from the diver(s), and
 - (2) Being aware of the amount and direction of line paid out to the diver(s).
- c. Attendant(s) are to be trained in the manual line signals being used and must remain alert at all times. Manual signals must be implemented **immediately** in the event of electronic communications failure.

14. **LWSSDE Additional Umbilical Marking.** If LWSSDE is used for the in-water divers and CABA is used for the Standby Diver, the LWSSDE umbilical may be longer than the Standby Diver's lifeline. In this case, the LWSSDE umbilical is to be clearly marked at the 45-metre mark (e.g. through the use of Day-Glo orange trail tape or similar marking). The attendant shall not permit the 45-metre mark to enter the water at any time. This marking is in addition to standard lifeline/umbilical markings and serves as a prompt to the diving team. Furthermore IOT prevent the 45-m mark to be passed, the umbilical must be secured topside to a hard point to prevent the 45-m mark from entering the water.

15. **Communications**

- a. Hardwire electronic two (or three) -way communications is recommended.
- b. If hardwire communications are not available, thru-water communications are permitted. However, operators must be aware of the potential of signal overload if more than one team is operating in a small area.
- c. When diving in pairs the Lead Diver is to send/receive all signals. The Buddy Diver receives all signals and acknowledges all orders after the Lead Diver when round-robin electronic communications are employed. In this situation, the Lead Diver shall use the call sign "Red Diver" and the Buddy Diver shall use the call sign "Yellow Diver".
- d. If electronic communications are lost, the diver(s) and attendant(s) will revert to manual signals.
- e. If there is any confusion/doubt as to what is being signalled, the Diving Supervisor must recall the diver(s) to clarify the situation.

16. **Conduct of the Dive**

- a. The Diving Supervisor will direct the Lead Diver to enter the hole after the dive brief and surface checks have been completed. This must be done carefully and slowly so as not to damage plastic/rubber components due to cold temperatures.
- b. Entering at a corner with the attendant's help is the preferred method of entry. Once in the water, the diver moves aside to allow the next diver to enter.
- c. During the dive all personnel should remain watchful for cold stress, hypothermia, frostbite and snow blindness.
- d. Except in an emergency, never operate/tend more than two divers from one entry/exit hole.

17. **Decompression Dives**

- a. The "No-D" time limit must be established prior to diving and briefed to the divers.
- b. In-water decompression should be avoided due to cold stress to the divers and support crew.

18. **Post-dive Procedures.** On completion of a dive, the diver(s) should be assisted out of a corner of the entry/exit hole (buddy diver followed by the lead diver) and escorted by attendant(s) immediately to a warm change area.

19. **Freeze-up Precautions.** To avoid equipment (regulator/mask/BC/drysuit) freeze-up:
- a. Ensure all components are dry and free of moisture prior to dressing-in.
 - b. Avoid allowing diving equipment to freeze overnight when ambient temperatures are extremely low; experience has shown that many components will malfunction when pressurized or operated the next day. Every effort should be made to protect all life support equipment from extended storage in freezing temperatures.
 - c. Do NOT breathe through the regulator on the surface except when using the AGA DIVATOR II.
 - d. Avoid using the purge button on second-stage regulators.
 - e. Avoid prolonged use of BDCMV/drysuit inflation valves during the dive.
 - f. Diver(s) should be well briefed on freeze-up emergency procedures (EP's) prior to the dive.
20. **Thermal Considerations.** The next diving team should remain warm in a sheltered area if possible until required on site. Hot soup/fluids should be available for all personnel. The Standby Diver must be kept as warm as possible and other support personnel rotated frequently. Warm clothing must be layered to prevent hypothermia and should include thermal underwear, a warm parka (waterproof/breathable material) or environmental suit (floater suit) for cold and wind protection, waterproof gloves and boots (insulated rubber boots).

SECTION 3

SECURING THE DIVE SITE

1. The following actions are to be completed upon completion of the diving operation:
 - a. Remove all equipment from the dive site.
 - b. Replace ice blocks in entry/exit hole.
 - c. Mark the site with stakes and highly visible marking tape to alert all person(s) of the danger area.
 - d. Return and remove stakes/tape from entry/exit hole after ice has sufficiently frozen.

SECTION 4

EMERGENCY PROCEDURES (EPs)

1. Freeze-up Emergency Procedures

a. To avoid frostbite when freeze-up occurs:

(1) If using AGA DIVATOR II, hold the mask in a position as to allow the escape of LP air. The inherent design allows for proper spacing between mouth/nose via the oral-nasal, thus reducing cold air effects. However, rapid and severe frostbite damage of gums and teeth can occur if care is not taken.

(2) In CABA switch to alternate air source.

b. Inform the Buddy Diver. The Buddy Diver should isolate the free-flowing air source (normally the diver's left cylinder).

c. Abort the dive.

d. Conduct a controlled ascent to the entry/exit hole.

2. Diver's Loss of Lifeline/Buddy Line (in all Conditions of Visibility). In the event of loss of the lifeline or buddy line:

a. Diver(s) must ascend to the lower ice surface, insert ice screw(s) or standard dive knife, switch on strobe lights and wait for the Standby Diver.

b. Consider inflating stabilization jacket, drysuit and/or ditching weights.

c. Hang vertically if possible to increase the possibility of snagging the search line.

d. If electronic communications are fitted, provide details of surroundings (e.g. vicinity of nearest spoke).

3. Lost Diver. In the event that an attendant loses or believes that the diver may have lost the lifeline:

a. The attendant shall IMMEDIATELY inform the Supervisor of how much line is out and in what direction. If electronic communications are used, communicate intentions to divers. The Supervisor will assess the situation and instruct the Standby Diver to enter the water, and direct another senior member to organize a surface search.

b. Upon entering the water, the Standby Diver, as directed by the Supervisor, proceeds straight to the end of the line in a direction 15 degrees to one side of the lost diver's last known or suspected position.

c. The Standby Diver/Attendant shall maintain a taught lifeline on the underside of the ice so as to best aid in the lifeline snagging on the lost diver. Once at the end, the Standby Diver begins to sweep 360 degrees towards the lost diver's probable position in attempt again to snag the diver(s)/ice screw. Should the search fail it should be repeated once more before moving the search to the most likely emergency hole.

NOTE

If not already cut, spare personnel should be immediately detailed to cut extra access entry/exit holes.

4. **Ice Failure.** Frequently the ice surface will move or sag, leading to slow flooding of the dive site. Bearing this in mind, some precautions can be taken to provide raised working platforms for personnel who would otherwise end up standing in near-freezing water for extended periods. As rapid failure of the ice surface can also occur, flotation suits, jackets, inflatable craft and similar safety equipment should be utilized as appropriate.

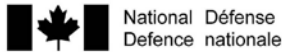

ICE DIVING EQUIPMENT — CABA / LWSSDE

ICE DIVING EQUIPMENT CHECKLIST

Check

1. Drysuit	Good condition	
2. Arctic wetsuit	Good condition (if MCW is not suspected)	
3. Mitts	Three-fingered	
4. Arctic hood		
5. Breathing apparatus		
6. Stabilization jacket		
7. Distress light (strobe)		
8. Indicating light	Chem-Lite or flashlight	
9. Working knife (standard)		
10. Safety knife		
11. Ice screw		
12. Two independent air sources utilized in one of the following two configurations:	LWSSDE Emergency cylinder (minimum 2265 litres (11 L at 205 bar)) with side block assembly. An alternate (octopus) second-stage regulator must be worn by the diver, and shall be worn by the standby diver. This cylinder is in addition to the secondary air source on the surface. The AGA mask is not to be substituted.	
	CABA As described in Section 2, para 10 of this Annex.	
13. Sufficient primary and secondary air sources must be available on site for the duration/depth of planned dive. The secondary air source must provide a minimum of another 33% of the calculated requirement of the task.		
14. Approved diver lifeline marked IAW Article 124. and Figure 1-2.		
15. Approved ice diving standby diver lifeline marked IAW Article 124. and Figure 1-2.		
16. Approved ice diving buddy line.		

Y583FP0132-00

Figure 5B-9 (Sheet 1 of 3) Ice Diving Equipment Checklist

ICE DIVING EQUIPMENT — CABA / LWSSDE		
ADDITIONAL ICE DIVING EQUIPMENT CHECKLIST		Check <input type="checkbox"/>
1.	DUOCOM RCC Subject to regulations on distance from nearest suitable treatment RCC facility.	
2.	Chemical lights 5 boxes	
3.	Ice auger, ice scrapers/chippers, ice tongs	
4.	Sounding line and electronic depth sounder and/or two depth gauges which incorporate maximum depth indication	
5.	Weighted shot line	
6.	Chainsaw Preferably two (due to water ingress to saw), canola oil (environmentally safe chain lubricant), tools and protective safety related equipment (cutting helmet, face screen or goggles, chaps and safety harness)	
7.	Handsaw, sturdy QTY 2	
8.	Axe QTY 2	
9.	Steel pegs/rebar QTY 12	
10.	Ice screws QTY 12	
11.	Hammer (large), sledge	
12.	Pieces of wood for securing lifelines QTY 4 (60 x 10 x 10 cm w/ hole in the centre to secure lifelines (if ice screws are not available))	
13.	Rubber matting or wooden pallets QTY 7 May require more for flooding around the entry/exit hole.	
14.	Ground tarpaulins As required	
15.	Plywood sheets QTY 4 Used with slotted pallets.	
16.	Benches, wooden QTY 4 (Wooden, NOT metal.)	
17.	Windbreak Large floorless tentage or tarpaulin on frame	
18.	Snow shovels/scoops QTY 8 Heavy-duty. Plastic preferred due to weight.	
19.	Toboggans QTY 4 Heavy-duty. Can be used to transport equipment/casualty. Snowmobile required for long distances.	

Y583FP0133-00

Figure 5B-9 (Sheet 2 of 3) Ice Diving Equipment Checklist

ICE DIVING EQUIPMENT — CABA / LWSSDE

ADDITIONAL ICE DIVING EQUIPMENT CHECKLIST (cont'd) Check

20. Snow blower	If conditions permit. Used to clear/maintain route to dive site, dive site and safety spokes.	
21. Thermometer	Air / water temperature	
22. U/W lights w/ lanyards	QTY 3	
23. Indicator lights (strobes)	One for each diver.	
24. Tool kits	Chain saw, diving equipment and misc. power machinery	
25. Portable stove	For warm liquids.	
26. Generator	For electric stove, coffee pot and lights if required.	
27. Propane, gas or electric heater	WARNING Danger of CO build-up and/or hypoxia in confined, non-ventilated areas.	
28. Air compressor	QTY 2 If available. Low temperatures increase failure rate. Always purge HP air before starting and after use.	
29. Various lengths of line, blocks, pulleys and crampons for hills/banks leading to dive site if required.		
30. B-GG-380-000/FP-002	CF Diving Manual, Vol. 2	
31. B-GG-380-000/FP-006	CF Diving Manual, Vol. 6, Diving Supervisor's Handbook.	
32. B-GG-380-000/FP-007	CF Diving Manual, Vol. 7, Aide-Mémoire du Superviseur de Plongée.	
33. Ground support vehicles	Vehicles must be adequate enough to carry all ice diving equipment and also be able to go "off road" (four wheel drive) for lakes that cannot be reached by maintained roads. The vehicles should be as close as possible to the dive site but NEVER on the ice.	

Y583FP0134-00

Figure 5B-9 (Sheet 3 of 3) Ice Diving Equipment Checklist

CHAPTER 6

STANDARD OPERATING PROCEDURES – SHIP'S DIVING

GENERAL

601. INTRODUCTION

1. The primary purpose of Ship's Team Divers (STD) is the protection of the ship from underwater sabotage attempts. This protection will include rapid hull inspections and limpet mine removal.
2. STD are also able to fulfill many other diving requirements of ships. This Chapter describes procedures peculiar to operational ship's diving. It should be used as a guide in planning and conducting operations involving ship's divers. Relatively simple tasks, such as recovering lost equipment or even locating the work site, may in some cases be complicated. Therefore, it is not possible to encompass all situations that have occurred or that are likely to occur. Accordingly, Ship's Team Diving Officers (STDO) must be prepared to innovate and adapt while staying within the framework of the diving regulations.
3. When working underwater, particular care should be taken with tools and articles easily dropped and lost. A tool bag or bucket should be used when carrying several tools or articles to the work site. In addition, a length of yellow or brightly coloured polypropylene line may be tied to each object so, if dropped, it may be more easily located. If the depth of water below the diver is greater than his/her qualification, recovery of an object can be difficult and at times impossible. This can compromise the task or result in a lengthy delay.
4. A few of the more common tasks encountered by STD are:
 - a. General ship's bottom/anode inspections,
 - b. Dome routines and inspections,
 - c. Plugging or patching discharges or intakes,
 - d. Propeller pitch calibration and
 - e. Poker gauge tests.
5. Each ship's team should have sketches or photos of the entire underwater portion of the hull readily available for use in locating hull openings and discharges. These drawings should indicate all underwater components, such as inlets, discharges, fittings and anode locations. STD should take advantage of any dry-docking to familiarize themselves with all underwater ship's fittings.

DIVING ON OR NEAR A SHIP'S BOTTOM

602. DIVING OPERATION REQUIREMENTS

1. When diving operations are planned to be under ships/vessels/submarines, the Diving Officer/Diving Supervisor shall ensure that a Diving Safety Checklist is completed (see [Figure 6-1](#) for a generic example, listing safety concerns found on many ships). Class-specific Safe-to-Dive Checklists must be created and kept up-to-date, since the fittings and hazards vary among each class in the fleet.
 - a. This checklist shall be retained by the Diving Officer/Diving Supervisor or in the case of diving conducted by a Fleet Diving Unit team, by the FDU Team Supervisor.
 - b. When diving under HMC Ships/Submarines refer to MARCORD, Vol. 1, 46-500, Annex B.
 - c. When diving under or near NATO Navy Ships the NATO Safe-To-Dive Certificate from ADIVP-1 (see [Figure 6-2](#)) must also be completed for each ship within 100 metres.

2. When diving operations are being conducted on or near a ship's bottom the Diving Supervisor shall ensure that the following precautions are strictly adhered to:
 - a. The Commanding Officer or OOW/OOD shall be informed before divers enter the water.
 - b. The Commanding Officer or OOW/OOD of the ship involved and all adjacent ships within 100 metres shall also be informed and shall present the Diving Supervisor with a completed and signed Diving Safety Checklist (Ship's class-specific SOP) before divers enter the water.
 - c. Propellers are to be locked with turning gear "IN". On the DDH 280 class, engine keys are to be locked in the Safe to Transmit Board.
 - d. Bow thruster is to be isolated and "Divers Down" signs are to be posted at appropriate positions.
 - e. When work is on or in the vicinity of the main inlets, whenever possible the main circulators should be **stopped** and the main inlet and discharge valves **shut**. If this is not possible, the main inlet circulation pumps are to be run at minimum rpm.
 - f. When work is on or in the vicinity of the ship's stabilizers,
 - (1) The breakers shall be opened at the switchboard and, where possible,
 - (2) The stabilizers are to be housed with the locking pin inserted.
 - g. Sonar transmissions shall not be permitted when divers are in the vicinity.
 - h. Sonar domes shall not be raised or lowered. All remote raise/lower circuit fuses shall be withdrawn and retained by the OOW/OOD. There will, however, be occasions when divers will be required to observe the lowering and raising of the ship's sonar dome. When this is necessary all divers must ensure that they are well clear of the dome.
 - (1) An effective communication method is to tap on the hull while another member of the ship's diving team is located in the sonar well and advises the inside operator when to raise or lower the dome. Two taps mean "lower" and three mean "raise". The inside diver answers the outside signals before acting or allowing the inside operator to work the dome.
 - i. The cathodic protection system is to be switched off.
 - j. A safety boat will be in the water at all times that divers are in the water, unless the diving operation can be conducted safely from a cat or similar platform close to the dive site.
 - k. The appropriate visual diving signals are to be displayed.
 - l. The Queen's Harbour Master (QHM), or equivalent authority in a Canadian port, and the appropriate harbour or port authorities are to be informed of the location, nature and expected duration of the diving operation.
3. When working on surfaced submarines, in addition to the foregoing, ensure that:
 - a. Hydroplanes and rudder cannot be operated.
 - b. Torpedo caps or doors are not operated nor water shots fired.
 - c. The main vents are harbour cotted.
 - d. The main ballast tank Kingston valves or flood valves are not operated.

e. The main ballast tanks are not blown.

f. The LP blower is not operated.

4. The above precautions are considered to be the **minimum** that must be followed to ensure the safety of diving personnel. It is not an all-inclusive list. Situations will occur that will require additional precautions to be taken.

5. Deviations from safety regulations are only permitted under special circumstances and must invariably be supported by written authority: for example, a SABEX operation order.



DIVING SAFETY CHECKLIST

ref: MARCORD 46-500

1. Location of Dive _____

(to include name(s) of ship(s) and specific hull area(s))

2. Date, Time & Planned Duration _____

3. Purpose of Dive _____

4. Diving Supervisor _____

5. Ship's Name _____

6. Notification of Key Personnel and Verification of Equipment Tag-Out
(to be completed by OOD/OOW or equivalent)

a. Notification of Key Personnel

- CO _____
 - XO _____
 - EO _____
 - CSE _____
 - Harbour Authorities (e.g. QHM) _____
- (initials)*
- (time signed)*

b. Verification of Equipment Tag-Out *(delete items not fitted)*

- | | |
|---|--|
| <ul style="list-style-type: none"> <input type="checkbox"/> Propellers secured <i>(including variable pitch)</i>; CPF <input type="checkbox"/> LOP and turning gear certified secure by Duty Tech <input type="checkbox"/> Bow thruster secured <input type="checkbox"/> Stabilizers secured <input type="checkbox"/> Sonar secured (transmissions plus raise/lower switch) – <i>includes fathometer/echo sounder and underwater telephone</i> <input type="checkbox"/> Cathodic protection off <input type="checkbox"/> Rudder(s) secured <input type="checkbox"/> Sea suction(s) secured <input type="checkbox"/> Diving signals displayed | <ul style="list-style-type: none"> <input type="checkbox"/> Sea discharge(s) secured <input type="checkbox"/> Z-drive propulsion de-energized <input type="checkbox"/> Submarines <i>(additional)</i> <input type="checkbox"/> Hydroplanes secured <input type="checkbox"/> Torpedo bow caps <input type="checkbox"/> Main vents harbour cottered <input type="checkbox"/> Ballast flood valves <u>not</u> to be operated <input type="checkbox"/> Main ballast tanks <u>not</u> to be blown <input type="checkbox"/> Low pressure blower secured <input type="checkbox"/> Garbage ejector |
|---|--|

I confirm that *(ship's name)* _____ is safe for the diving operations described in para 1 above to proceed. Precautions listed have been taken and will remain in effect until notified by the Diving Supervisor, in person, that diving operations are complete.

OOD/OOW _____
(or equivalent) (signature, date, time)

Diving Supervisor _____
(signature, date, time)

NOTES

1. A separate checklist is to be completed for each ship on which diving is to be conducted and for all other ships within 100 metres of the planned dive.
2. This completed form is to be retained by the Diving Supervisor until the completion of the diving operation. The Ship's Diving Officer must retain it for one (1) month after completion of the dive.

Figure 6-1 Diving Safety Checklist

SAFE TO DIVE CHECKLIST – SMALL CRAFT

NOTE 1: All vessels within 100 meters of any planned dive site are to complete a Diving Safety Checklist.

NOTE 2: This “Safe to dive check list – Small Craft” is intended to address safe clearance of small craft where the majority of equipment and machinery specified at Ref is not applicable.

NOTE 3: Small craft are defined as naval auxiliary vessels and civilian boats less than 100 ton that clearly do not incorporate the fitted machinery and underwater hazards that would be normally present on a ship.

NOTE 4: When doubt exists as to whether the vessel may be considered small craft – a Diving Safety Checklist shall be completed IAW Ref A & B.

NOTE 5: When multiple small craft are nested together under the charge on one Master / Captain / OPI, a single “safe to dive check sheet – small craft” may be used. All craft are to be listed and confirmed to be in the same safe to dive state.

A) TO BE COMPLETED BY DIVE SUPERVISOR

1. LOCATION OF DIVE: _____
2. NAME OF VESSEL(S): _____ / _____ / _____
_____ / _____ / _____
3. VESSEL’S CAPTAIN / OIC: _____
4. CONTACT INFO: _____
5. DATE / TIME: _____ / _____
6. DURATION: from _____ (local) / until _____ (local)
7. PURPOSE OF DIVE: _____
8. DIVING SUPERVISOR: _____
9. LOCAL HARBOUR AUTHORITIES (QHM) NOTIFIED _____
10. DIVING SIGNALS DISPLAYED: _____

B) TO BE COMPLETED BY VESSELS CAPTAIN / OIC

11. MAIN ENGINES SHUT DOWN _____
12. THROTTLE CONTROL PIN IN: _____
13. IGNITION KEYS REMOVED: _____
14. AUXILLARY MACHINARY SHUT DOWN: _____
15. U/W INTAKES SECURED: _____
16. ALL MEANS OF OVERBOARD DISCHARGE ISOTATED: _____
17. RUDDER / Z DRIVE / IO LEG SECURED: _____
18. BOW THRUSRTER SECURED: _____
19. STABILIZERS / TRIM TABS SECURED: _____
20. CATHODIC PROTECTION OFF: _____
21. ALL U/W ELECTRONIC TRANSMISSION (sonar, etc) OFF: _____

I confirm that _____ is safe for diving operations as described above. Precautions listed have been taken and will remain in effect for the time period indicated or until notified by the dive supervisor (in person) that diving operations are complete. The following exceptions to (B) are noted as follows:

Vessels Captain / OIC _____
(signature date time)

Dive Supervisor
Signature: _____

NOTE 6: The diving supervisor shall hold this completed form until completion of the dive. It must be retained for a period of one month upon completion of the dive. A completed copy shall be provided to the vessels Captain / OIC upon request.

Figure 6-2 Diving Safety Checklist



NATO Safe-To-Dive Certificate

REFERENCES ADivP para 0201e

e.g. OPORD/Serial _____

FOR _____

Ship's name

START TIME _____ **DTG** (*local times to be used*)

COMPLETION TIME _____ **DTG**

OTHER UNITS INVOLVED (*Ships adjacent or within 100 metres*) _____

DIVING TASK

Purpose _____

Location _____

Port _____

Vessel(s) to be dived on (*includes seabed under*) _____

Berth _____

Area of Ship (*if applicable*) _____

Authorized Deviations from Standardized Safety Precautions _____

I certify that the diving team is properly equipped and trained to carry out the required task.

Signature of Diving Supervisor

Name & Rank

It is certified that all required actions as stated on the attached checklist have been taken IAW: National Regulations / A DivP-1 para 0216 (*delete one if applicable*) to ensure that it is safe to dive on or in the vicinity of:

during the period stated.

Signature of Commanding Officer

Name & Rank

Date/Time

NOTE: ADivP-1 is to be consulted, since NATO may have promulgated modifications to this procedure. Refer to Article 603. for additional Canadian Forces safety precautions applicable when diving on foreign vessels.

Figure 6-3 (Sheet 1 of 2) NATO Safe-to-dive Certificate



NATO Safe-To-Dive Certificate

PERIOD OF DIVING OPERATION _____ **DTG to** _____ **DTG (local)**

PURPOSE OF DIVING OPERATION

(what & where)

In all cases controls must be labelled 'TAGGED-OUT FOR DIVING OPERATIONS' to prevent inadvertent operation.

CHECKS TO BE COMPLETED

MECHANICAL ENGINEERING

- Propellers, other thrusters, rudder(s), stabilisers and other underwater moveable gear (*e.g. S/M hydroplanes*) **IMMOBILISED.**
- All underwater inlets and outlets rendered **INOPERATIVE** (particularly main circulators and boiler blow-down valves).
- Cathodic protection **SWITCHED OFF.**

COMBAT SYSTEMS

- No sonar transmissions to be made (*includes fathometer/echo sounder & UWT*).
- Sonar domes and probes **IMMOBILISED.**
- Inform Ship's Company at 15-minute intervals that diving operations are taking place.

- Diving signals displayed.
- Degaussing system **SWITCHED OFF.**
- Torpedo tubes rendered **INOPERATIVE** /tube caps **IMMOBILISED.**

DECK

- No heavy items to be deployed over the side or moved (*e.g. anchors, boats, cargo & large fenders*).
- No boat traffic to be permitted except for the diving safety boat(s).

GENERAL

- Local Port Authority informed and permission to dive obtained including confirmation that no operations hazardous to divers will be undertaken within 100 m of the dive site during the period of the dive (*e.g. operation of dock inlets/outlets*).

PERSONS RESPONSIBLE

Signature & DTG

Name & Rank

NOTE: The minimum safety requirements for diving on vessels are listed above. They also apply to other vessels within 100 metres of the diving operations. Additionally, nations may use these requirements as a basis for more detailed checklists that are ship or class-specific.

Y583FP0138-00

Figure 6-3 (Sheet 2 of 2) NATO Safe-to-dive Certificate

603. DIVING OPERATIONS ON FOREIGN VESSELS BY CAF DIVERS

1. In addition to the precautions taken at [Article 602](#), further measures are necessary to address hazards that may not yet be covered under NATO procedures.
2. When diving on foreign warships the Commanding Officer shall ensure that:
 - a. Only diving that is deemed operationally essential is conducted on foreign warships/vessels.
 - b. Routine or pre-planned employment of CAF divers for operations such as inspections and maintenance is to be avoided. Such underwater services should be referred by the requesting navy up its respective national chain of command. Several navies have fly-away or deployable teams specifically for such purposes.
 - c. In the event essential diving ops must occur, the following additional safety precautions beyond [Article 602](#) are to be taken:
 - (1) Diving Supervisor in company with HMC ship's Marine Systems Engineering Officer (MSEO) are to physically sight that the MSEO/or equivalent of the foreign warship has secured the foreign ship for diving IAW NATO Safe to Dive Certificate.
 - (2) Both ship's MSEOs and the ship's Diving Supervisor are to co-sign the certificate required by DGM 09/01/A.
 - (3) HMC ship's MSEO and Diving Supervisor are to brief HMC ship's Commanding Officer on completion of securing the foreign warship for diving.
 - (4) A sentry shall be posted on the upper deck on the foreign vessel to assist the Diving Supervisor. This sentry shall be thoroughly briefed by the CAF Diving Supervisor and have a ready means of communicating within the foreign vessel.
 - (5) Ensure methods of efficient communication to the foreign ship's engineering department are well known in the event underwater systems are inadvertently activated during the dive (e.g. Internal broadcast systems, intercoms or PRCs).
 - (6) If the above measures cannot be accomplished diving is NOT to occur.
3. EXCEPTIONS: the only deviations from this policy are:
 - a. Clearance Diving Teams (CDT) composed of clearance divers under supervision of a CLDO, CI Div QL6A or 6B do not deploy with an MSEO and thus do not require a Canadian MSEO to accompany the Diving Supervisor when determining the safe-to-dive status of a vessel. When available, a senior MAR ENG ART/TECH (or equivalent) should be requested to assist in verifying status, and
 - b. On written authority of CO PSU (when stood up), a QL 4 Port Inspection Diver (PID) in charge of a diving team supporting the PSU operation may follow the direction at [paragraph 3.a.](#)

SHIP'S DIVERS DIVING SEARCHES

604. GENERAL

1. Underwater searches are broken down into several categories, including:
 - a. SHIP'S BOTTOM SEARCHES,
 - b. SEABED SEARCHES, and
 - c. JETTY SEARCHES.

2. This chapter will deal with the naval diver's (CI Div, PID, STD) role in ship's bottom searches. Seabed and jetty searching is covered in [Chapter 5](#).

605. SHIP'S BOTTOM SEARCHES

1. As with seabed searches, ship's bottom searches are an important part of the duties of STD. The problem is similar: the area to be searched is smaller but so is the object to be located, e.g. a ship's fitting or a limpet mine placed by underwater saboteurs.

2. The principles applied in seabed searches are also applied to ship's bottom searches, with techniques suitably modified. It is extremely important to the safety of the divers to adhere to the search methods as described and to avoid local modifications and any attempt to combine other diving modes, such as buddy diving, with a partial search team method. Such modifications have caused fatalities in the past.

3. Divers must be given every opportunity to become familiar with the various configurations of ship's bottoms. Whenever a ship is alongside the diving team should take the opportunity to exercise with hull search and disposal equipment. In addition, when dry-docked the diving team should familiarise themselves with the hull configuration and all of the ship's underwater fittings.

4. A selection of underwater lights is available to assist the diver in searching a ship's bottom. The particular type of illumination and techniques used depend on the underwater conditions. Plankton and particles in suspension in the water may often preclude the use of high-power lighting, but low-power lights or divers' search lamps may be effective. However, divers should never become wholly reliant on lighting and must practice operating solely by touch.

5. A number of search schemes are described in subsequent articles. Within the scope of the diving regulations, these articles may be adapted as necessary to suit the ship and local conditions. STD or the Diving Supervisor will base the choice of search scheme on the following factors:

- a. Underwater visibility,
- b. Tidal conditions or current,
- c. The underwater fittings of the ship concerned,
- d. The number of divers available and their state of work-up and
- e. The diving equipment available.

606. FREE AREA AFT SEARCHES

Free area aft searches for search schemes "A" and "B" shall be conducted IAW the rules and regulations laid out in [Articles 120](#) and [121](#).

607. SEARCH SCHEME "A" – NECKLACE SEARCH

1. Experience has shown that the necklace search ([Figure 6-4](#)) or variant thereof is the most adaptable for searching a ship's bottom or jetty. It is faster than any other search and all divers are in constant communication with each other. For safety it is important that the divers frequently verify the presence of the divers adjacent to them, particularly when visibility is poor. The absence of a diver is to be treated as a lost diver emergency IAW [Chapter 2](#).

2. The following equipment is required:

- a. One lightweight line (the necklace line), long enough to reach from the waterline, around the ship's bottom amidships, to the waterline of the opposite side.
- b. Two floats.

- c. Indicating lights for floats.
 - d. Diving equipment.
3. The necklace line is made up as follows:
- a. The line is prepared in two sections joined at the middle with non-swivel Inglefield clips ([Figure 6-4](#)). It shall be long enough to pass under the hull and reach the surface on each side.
 - b. A light float is spliced at each surface end of the necklace line.
 - c. At desired intervals a diver's hand loop, 1-metre maximum in length (see [Figure 6-4](#)), is spliced into the necklace search line. Alternatively, non-locking Carabiners secured to the diver may be attached to the search line. This method speeds up connecting divers to the search line and permits ease of search intervals if the visibility changes.
4. Divers enter the water, take up their allocated positions and attach themselves to the search line. The surface swimmers at each end of the search line need not be divers as long as they are capable of swimming with a snorkel and facemask and understand diving signals. They hold the necklace line, attend the float and search above and below the waterline.
5. All divers and surface swimmers shall wear an indicator light at night.
6. The search should generally start from forward and work aft, but this will depend on local tide and weather conditions.
7. If a mine is found, the drill taught by the FDUs and Command is to be carried out. Further information may be found in NAVORDs, *Ship Standing Orders*, CFCD 102, 108, Force Protection SOPs and Orders and classified publications held aboard each ship.

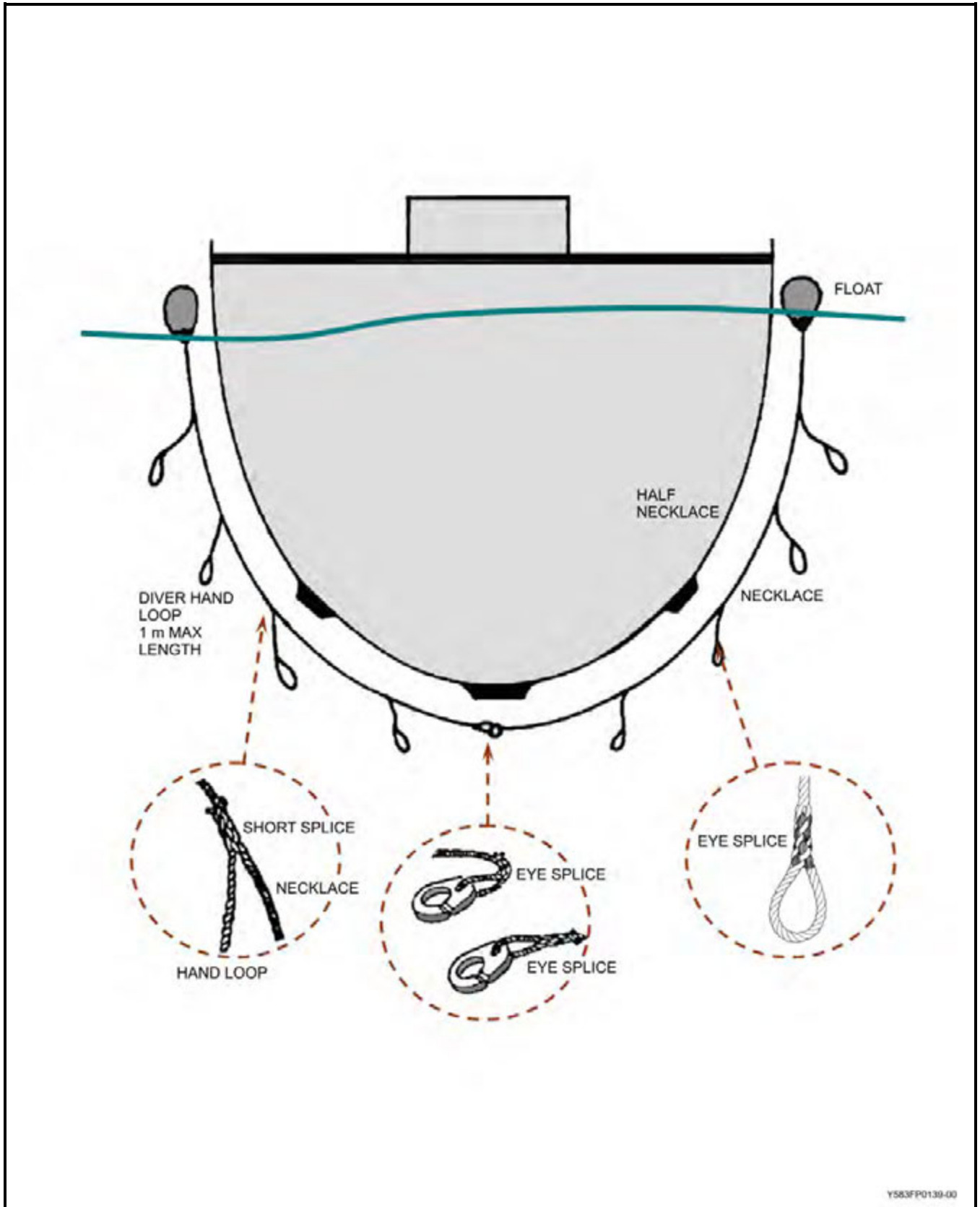

Figure 6-4 Search Scheme "A" – Necklace Search

608. MODIFIED SEARCH SCHEME “A” – HALF-NECKLACE SEARCH

1. Instead of having a necklace of divers encircling the complete hull, the search can be used efficiently in two passes or sweeps as a half-necklace ([Figure 6-4](#)), by searching from the keel to the surface on one side and then repeating the operation on the other side.
2. The half-necklace line is made in the same way as a full necklace line, with a float at one end and the Inglefield clip at the keel end.

NOTES

1. In depths of water greater than 30 msw, the CAF Diver’s Float (NSN 2090-21-912-1525) shall be used for all necklace searches.
2. In depths of water 30 msw or less, the standard CAF Diver’s Float is not mandatory for use on the necklace search. A smaller marker float capable of being pulled under obstructions such as fender logs or other ships may be substituted.
3. The necklace search may also be used by diving teams to search jetty faces/seabeds under the same restrictions as [paragraphs 1](#) and [2](#), subject to the least depth qualification on the team.

609. SEARCH SCHEME “B” – ZIG-ZAG SEARCH

1. Search Scheme “B” ([Figure 6-5](#)) is for STD not meeting the standard of efficiency required for necklace searches and requires a lifeline. The zig-zag search is a very thorough search, although much slower than the necklace search.
2. Carry out Search Scheme “B” using the following in addition to normal diving equipment:
 - a. Bottom lines, one for every 60 metres of ship’s length.
 - b. One (64-metre) codline jackstay wound on a wooden core for each diver.
 - c. A lifeline for each diver.
3. The search scheme is executed by divers swimming between bottom lines using the jackstay to trace the course of their search.
4. Divers may be employed on simultaneous jackstay searches in as many areas as their numbers permit.
5. If all areas cannot be searched at once, give priority to the most vulnerable parts of the ship.
6. Each zig-zag search proceeds as follows (see [Figure 6-5](#)):
 - a. Diver secures jackstay to bottom line “A” at “P” (visibility distance (V) above the keel). When visibility is nil, “diver’s arm reach” should be substituted for “visibility distance”.
 - b. The diver swims to bottom line “B” paying out the jackstay and searching below as the diver proceeds.
 - c. If the keel cannot be distinguished, the diver may go to the bilge keel or return to the waterline to “B” in order to continue the search without interruption. Care must be taken to place the jackstay on “B” at “Q” (V above the keel) ensuring that the jackstay is hauled taut.
 - d. The diver swims along the jackstay to “P”, searching above. The diver must search below as well if not already done.

- e. On arrival at "**P**", shift the jackstay up the bottom line twice visibility (**2V**) distance to "**R**".
- f. The diver swims back along the jackstay, searching above and below it.
- g. On arrival at "**Q**" shift the jackstay up the bottom line twice visibility distance to "**S**".
- h. The diver continues this process until reaching the waterline.

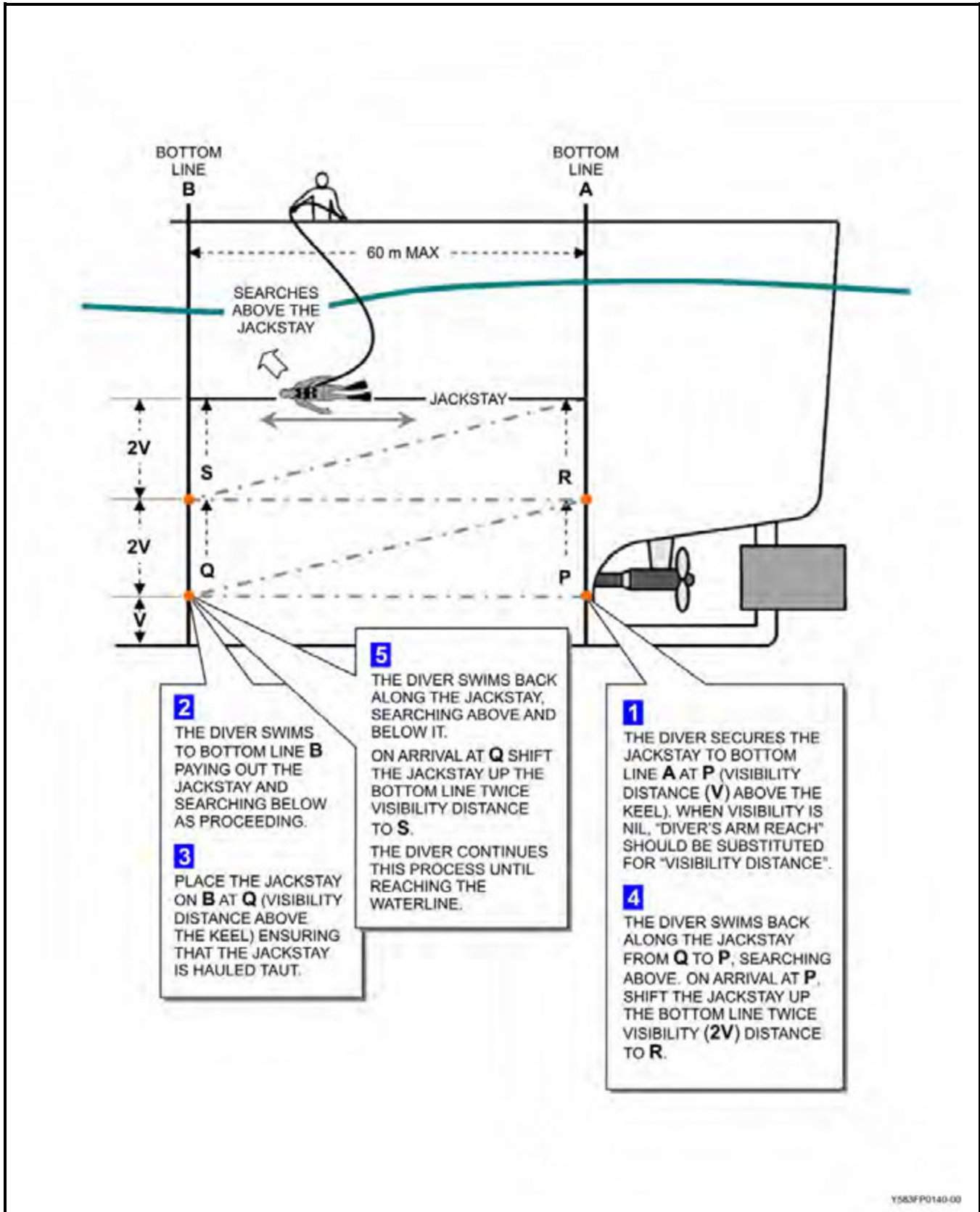

Figure 6-5 Search Scheme "B" – Zig-zag Search

610. SEARCH SCHEME “C” – LADDER SEARCH

1. Search scheme “C”, the ladder search ([Figure 6-6](#)), should be used when underwater visibility is such that a necklace search or a half-necklace search cannot be carried out. This search scheme requires more divers than search scheme “B” (zig-zag search).
2. Only Clearance Divers may use search scheme “C” (ladder search), as free-swimming is essential.
3. The advantages of search scheme “C” over search scheme “B” are as follows:
 - a. Overlaps do not occur; therefore the search is completed more quickly.
 - b. Divers work in pairs, an added safety factor.
4. In addition to normal diving equipment the following equipment is also required to carry out search scheme “C”:
 - a. Bottom lines, one for every 60 metres of ship’s length, and
 - b. One 64-metre codline jackstay wound on a wooden core for each pair of divers.
5. The search scheme is executed by a pair of divers who trace the course of their search with jackstays, one diver swimming below the jackstay, the other above. They swim in opposite directions.

NOTE

When visibility is nil, “diver’s arm reach” should be substituted for “visibility distance”.

6. Divers search as many areas at once as their numbers permit. If all areas cannot be searched together then priority must be given to the most vulnerable parts of the ship.
7. Each search proceeds with divers working in pairs, one member of each pair being designated as leader (DIVER No. 1):
 - a. With their jackstay between them, the divers go down their respective bottom lines – “A” and “B” – to the keel.
 - b. On arrival at the keel, DIVER No. 2 secures the end of the jackstay to bottom line “A” at visibility distance (**V**) above the keel and gives 2 -PULLS on the jackstay to inform DIVER No. 1 that the jackstay is secured.
 - c. DIVER No. 1 hauls taut the jackstay and secures it to the bottom line “B” at visibility distance above the keel. DIVER No. 1 then gives 2 -PULLS on the jackstay.
 - d. Both divers then swim along the jackstay, DIVER No. 1 searching above and DIVER No. 2 searching below.
 - e. On completion of the first search, the leader gives two pulls to instruct DIVER No. 2 to move his/her end of the jackstay up the bottom line twice the visibility distance (**2V**). When this has been done, DIVER No. 2 diver gives 2 -PULLS on the jackstay and the leader moves his/her end up the bottom line twice the visibility distance (**2V**).
 - f. The leader gives 2 -PULLS as a signal to search as before, DIVER No. 1 above the jackstay and DIVER No. 2 below.
 - g. The divers continue this process until they reach the waterline.

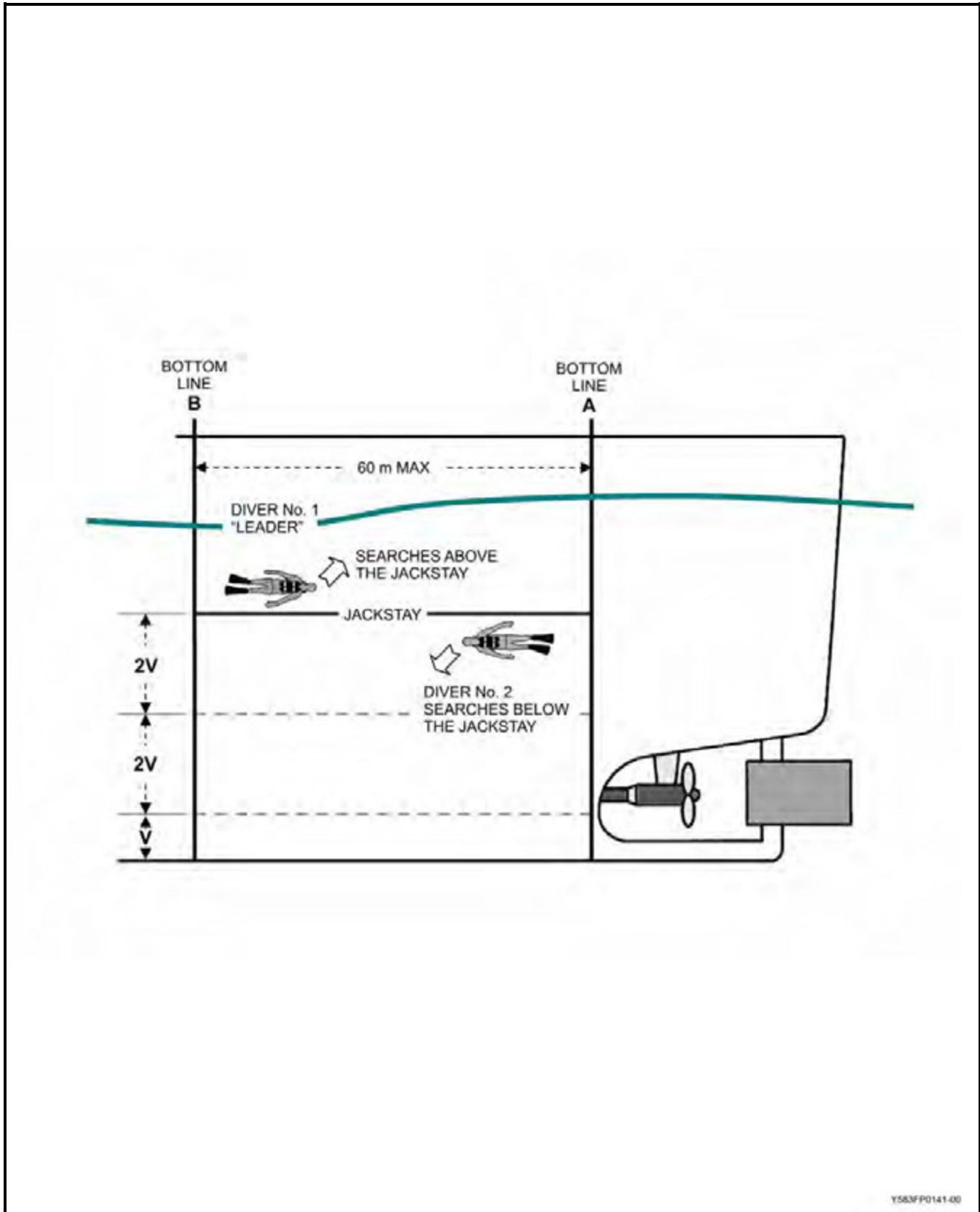

Figure 6-6 Search Scheme "C" – Ladder Search

611. EMERGENCY STATIONS

1. The ship may go to emergency stations for a number of reasons; however, divers are not required in all situations. The following is a list of emergency stations that may require STD involvement:

- a. RESCUE STATIONS,
- b. RAFT STATIONS,
- c. ABANDON SHIP,
- d. EMERGENCY FLYING STATIONS,
- e. FORCE PROTECTION PROCEDURES, and
- f. SABOTAGE EXERCISE (SABEX).

2. When a ship goes to emergency stations requiring divers, the STDO shall take positive control of the diving activities as required by the Commanding Officer.

3. Standard operating procedures, emergency procedures and divers' emergency station responsibilities shall be promulgated and posted in the diving locker area.

612. LIMPET MINE DISPOSAL EQUIPMENT

1. Limpet Mine Disposal Equipment (LMDE) is the primary weapon utilized by Ship's Team Divers to neutralize underwater anti-ship sabotage devices.

2. The LMDE is a weapon and shall be exercised and maintained by the diving team on a regular basis.

3. LMDE standard operating procedures, safety precautions and maintenance instructions are outlined in BR 8525, *LMDE Manual*, and MARCOM BR 8525, addendum. Also refer to [Article 121](#), *Free-Swimming – General Rules*.

NOTE

Limpet Mine Disposal Equipment (LMDE) and associated procedures are CLASSIFIED.

SUBMARINE SHIP'S DIVER**613. GENERAL**

1. STD in HMC Submarines will encounter tasks unlike those found in ships. Procedures for plugging inlets and conducting underwater searches are basically the same. Brief notes on those items unique to submarines are contained in subsequent Articles. Note that this section contains general guidance only and does not reflect the specifics of the VICTORIA class. All new procedures developed must be approved by Formation authorities in consultation with the appropriate FDU, in order to ensure safety and if necessary, the development of formal training. Diving in confined spaces is of particular concern in this regard.

614. BLANKING PLATES

1. Blanking plates are used to seal off the free flood openings of the ballast tank. A "blow-around" must be conducted before blanking off any ballast tank.

2. Once the blanking plate is secured in position and before opening the manhole, the main vents for that particular tank must be opened to check that the seal on the blanking plate is watertight.

615. BOW CAP SEALS

1. STD can replace bow cap seals. The underwater weapons personnel should be consulted to verify that the fitting of the seal is correct.

616. VELOCIMETER

1. The transducer is secured behind a hinged grate. The procedure for removal is straightforward once the grate (held by Allen screws) is removed.

617. UNDERWATER TELEPHONE

1. Removing the transducer is a simple procedure but replacing it is more difficult due to the weight of the transducer and the angle of the transducer receptacle.

2. A suggested method is to thread three (3) steel guide rods, each 305-mm in length, into the boltholes to assist in sliding the transducer into place. Start some of the securing bolts before removing the guide rods.

618. TORPEDO TUBE TEST DOORS

1. Check current publications for details and procedures on fitting of torpedo tube test doors.

619. DECOMPRESSION IN SNORTING SUBMARINES

1. Pressure variation caused by snorting will affect post-dive decompression similarly to flying after diving. Refer to [Articles 312](#), *Diving and Snorting Submarines* and [313](#), *Flying After Diving*.

AIRCRAFT RESCUE AND RECOVERY

620. GENERAL

1. Several classes of ships carry helicopters and STD must be familiar with the techniques for the rescue and recovery of these aircraft.

2. Shipboard publications (*e.g. HELP*) cover in detail the methods for recovery of a downed helicopter and safe procedures for crew rescue.

3. STD should make themselves completely familiar with their ship's aircraft so that in the event of a mishap they can react quickly and correctly in the rescue and recovery operations.

4. Helo floatation collars may be available in some ships. The team should be familiarized with correct procedures of use.

CHAPTER 7

COMBAT DIVING

701. OVERVIEW

1. Diving in the Land Force began in the 1960's when, as a result of the introduction of amphibious vehicles, it was essential to provide a diving capability to the safety organization for the swimming of vehicles. Amphibious operations also required a better capability for the underwater reconnaissance of crossing sites. Other tasks such as obstacle construction/breaching and the employment and detection of mines were eventually added. Following trials in 1966, in 1969 diving sections were established in combat engineering units.

2. With the loss of amphibious vehicles from the CAF inventory and recent conflicts demanding the landing of CAF troops on unfriendly shores, the role of the combat diver has become more critical to ensure the mobility of the Army. Be it finding and clearing fording/bridge sites to working with special force units and the Navy, Combat Divers ensure CAF troops can safely land on a foreign beach.

3. Combat Divers are Combat Engineers who perform the combat diving function as a secondary duty. They provide formations with the capability of projecting their will on to and under the water. They are capable of conducting tasks inland within close proximity of the shoreline as surface swimmers, or beneath the water with the aid of breathing apparatus. Proficient combat divers have a high probability of reaching the enemy bank or shore and executing their tasks undetected.

4. This Chapter provides a general overview of Combat Diving Operations. Additional information and direction concerning Land Force combat diving is detailed in B-GL-361-001/FP-001, Land Forces Engineer Operations, Chapter 10, "Combat Diving", and B-GL-361-007/FP-001, Field Engineer Manual, "Combat Diving".

702. THE ROLE OF THE COMBAT DIVER

1. The role of the Combat Diver is to extend Combat Engineer operations beyond land and into the water.

703. TASKS

1. Combat Diving tasks can be grouped into three of the six combat functions:

- a. **Manceuvre.** Maintains mobility,
- b. **Protection.** Counter-mobility and survivability, and
- c. **Sustainment.** Sustainment engineering.

2. [Figure 7-1](#), *Combat Diving Tasks*, details a summary of combat dive tasks and the level at which they are performed.

Serial No.	Task	REQ'D LEVEL DIVING EXPERTISE		
		DIVISION & BELOW		CORPS & THEATRE
		Close Support	General Support	
1	RECONNAISSANCE			
	• Water crossing site	X	X	X
	• Landing site & beach (see NOTE 1)	X		Special Forces
	• Engineer task	X	X	X
2	DEMOLITIONS			
	• Removal/destruction of U/W/surface obstacles	X	X	X
	• Destruction of piers, docks & U/W installations			X
	• U/W detection, neutralization & destruction of unexploded ordnance as part of Battlefield Area Clearance operations	X	X	X
3	MINE WARFARE & OBSTACLE CONSTRUCTION			
	• Construction of underwater obstacles including placement of mines	X		X
4	CONSTRUCTION			
	• Examination & repair of bridge piers & floating bridge equipment		X	X
	• Laying & repairing U/W pipelines and communication lines			Specialized Divers
	• Construction, maintenance & repair of docks, piers, U/W sewage systems & water systems			X
5	SAFETY, SEARCH & RECOVERY			
	• Safety Standby (SEE NOTE 2)	X	X	X
	• Search & Recovery		X	X
	• Special Operations			Special Forces

Y583FP0142-00

Figure 7-1 Combat Diving Tasks

NOTES

1. Currently the CAF does not conduct amphibious landings from the sea, other than unopposed landings to support Logistics Over-The-Shore (LOTS) operations. Normally the Navy will provide the diving support required for these operations. In some circumstances, combat divers may be tasked for this type of mission, which would require extensive re-grouping, training and co-ordination.
2. Combat divers may also perform safety standby duties in support of water crossing operations. This is essential in peacetime training and may be required during combat or other operations.

704. KEY ARMY DIVING APPOINTMENTS

1. The Office of Primary Interest Army Diving (OPI Army Diving) is held by the Commandant of CFSME. The OPI of Army Diving is the authority for all matters of policy and issues concerning combat diving as well as instructing the field engineer phase of the Combat Divers Course. Refer to [Article 103](#) for CAF Diving policy and authorities.
2. Changes to Army-specific diving procedures require OPI of Army Diving direction.
3. The Officer in Charge Army Diving (OIC Army Diving) is a Senior Diving Officer with the rank of Major, and is appointed by the OPI Army Diving. OIC Army Diving commands the Army Dive Centre located within CFSME.
4. Sergeant Major Army Diving (SM Army Diving) is a qualified Combat Diving Supervisor, MWO or WO, appointed by the OPI Army Diving, and also resides at the Army Dive Centre.
5. The Army Diving Centre (ADC) is located within CFSME and in addition to OIC and SM Army Diving, is staffed by two AHNX-qualified Sergeants and an ADUV-qualified Corporal. It is mandated to develop combat diving doctrine, training, techniques and procedures.

705. UNIT DIVING ORGANIZATION

1. The Unit Diving Officer is a qualified Combat Diving Officer, usually holding the rank of Major, and is responsible to the CO for all Unit diving.
2. The Unit Liaison Diving Officer is a Combat Diving-qualified officer in the rank of Captain/Lieutenant, and is responsible for liaison with external organizations when required.
3. Dive Stores Section Commander is a Sergeant or Master Corporal, qualified as a Combat Diving Supervisor. Dive Stores Section Commander provides advice and guidance to Diving Officers and Diving Section Commanders, and assists in the planning of tasks, administration and training of Unit divers, and is responsible for the maintenance of diving equipment and stores.
4. Diving Section Commander is a Diving Team Leader, Sergeant or Master Corporal, qualified as a Combat Diving Supervisor, and is responsible for the actual detailed planning and execution of a task.
5. Dive Storesman is a Corporal, qualified Combat Diver, and is responsible for the maintenance of diving stores and equipment, and assists in the planning and co-ordination of tasks.
6. For further description and responsibilities of diving appointments and organizations refer to B-GL-361-007/FP-001, Field Engineer Manual, "Combat Diving" Chapters 1 and 7.

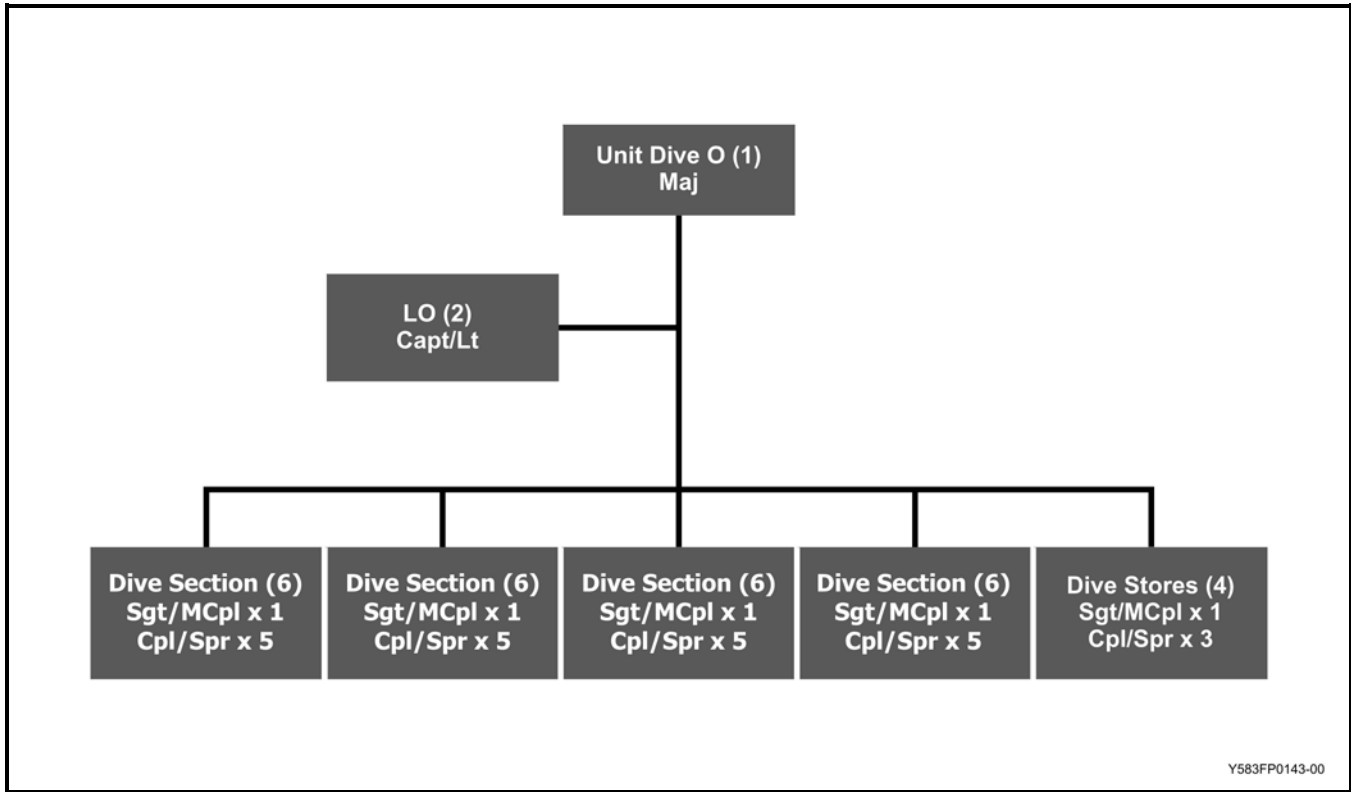

Figure 7-2 Combat Engineer Regiment (31 Divers)

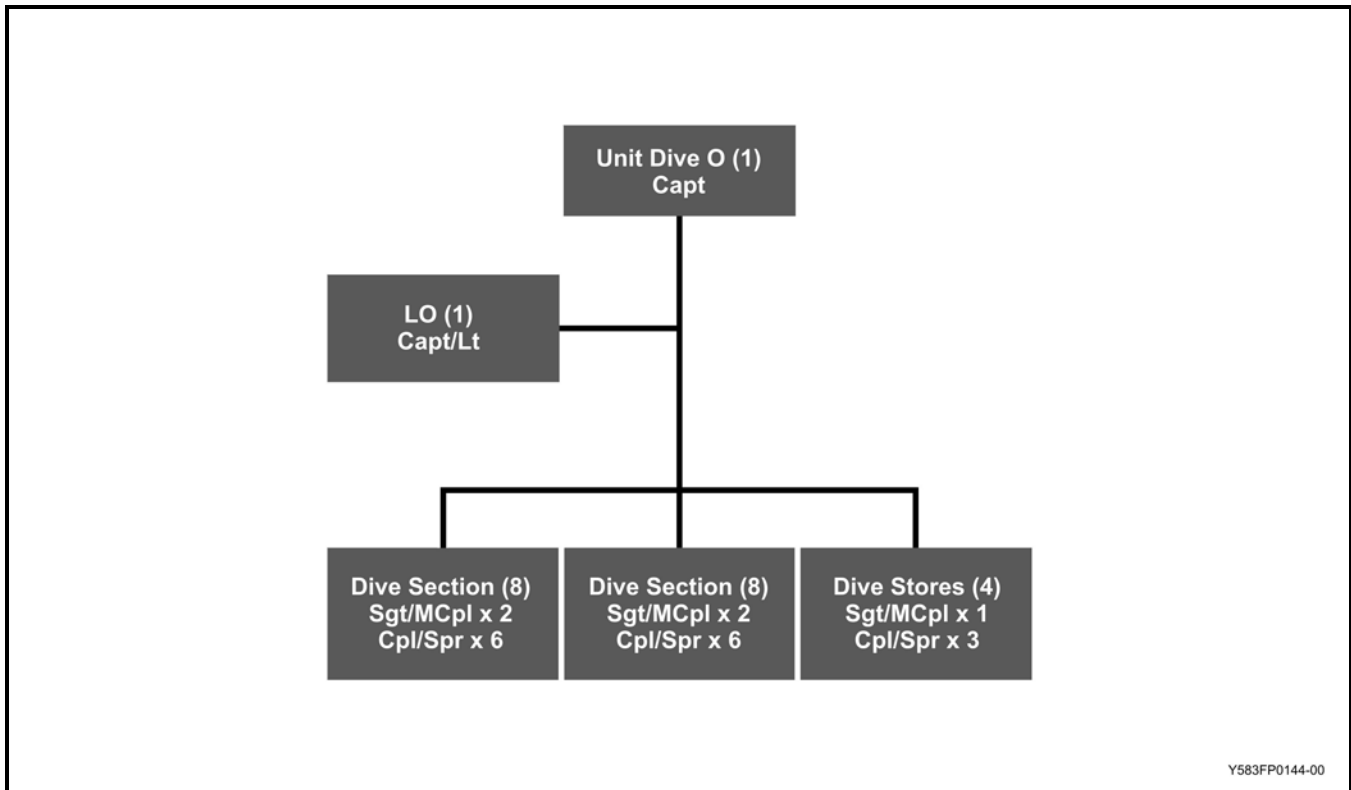

Figure 7-3 Engineer Support Regiment (22 Divers)

706. EMPLOYING COMBAT DIVERS

1. Combat Divers execute tactical missions in support of army operations.
 - a. They have the capability of crossing water obstacles and transporting limited amounts of equipment and stores for use in or beyond the immediate confines of the water.
 - b. They have a limited ability to sustain and protect themselves and generally do not engage in direct action against the enemy.
2. Combat diving operations extend beyond the scope of other CAF diving establishments. There are unique considerations relevant to the employment of combat divers as follows:
 - a. During operations combat divers may be required to conduct tasks independent of surface support personnel and safety organizations.
 - b. They will use explosives, small arms, equipment and tools on and under the water, and be exposed to the inherent risks of this function and
 - c. They have a greater chance of exposure to chemical and biological contaminants in the routine conduct of tasks than other soldiers.
3. When combat divers support and conduct tasks with other engineers and arms, the senior diver present co-ordinates the dive task and advises the local commander on dive-related issues.
4. Combat divers can use a wetsuit or a drysuit depending on operational or environmental conditions. Combat divers may conduct operations in one of the following ensembles or modes:
 - a. **Combat Swimmer.** Combat divers, as surface swimmers, can cross water obstacles. Given the proper conditions, surface swimmers can be effective.
 - (1) They are, however, vulnerable to detection by the lowest forms of surveillance systems.
 - b. **Compressed Air Breathing Apparatus (CABA).** Combat divers with breathing apparatus can conduct tasks within their depth limitation, no-decompression limits and endurance.
 - (1) Open-circuit equipment has limited tactical application when stealth is critical to mission success.
 - c. **Closed or Semi-closed Circuit Breathing Apparatus.** Combat divers, using closed or semi-closed circuit breathing apparatus can cross water obstacles and conduct tasks with a high degree of stealth. This equipment is generally fabricated of non-magnetic and composite materials. These systems increase diver endurance and efficiency when submerged. Combat divers using closed- or semi-closed circuit breathing apparatus can execute tasks with the highest degree of stealth. This capability is not currently authorized for CAF Combat Divers.
 - d. **Light-weight Surface-supplied Diving Equipment (LWSSDE).** This is an open-circuit, compressed air, surface-supplied umbilical system. Combat divers can use this equipment to access drowned vehicles, confined spaces or for sustainment tasks. This system allows audio communications between the diver and surface. It provides positive control of a diver, as individual divers are tended from the surface or from an entry point into a confined space/drowned vehicle.
5. When considering the use of Combat Divers, refer to B-GL-361-007/FP-001, Field Engineer Manual, Chapter 2, "Combat Diving" for additional information.

707. PRINCIPLES OF COMBAT DIVER EMPLOYMENT

1. The critical path for the successful execution of a combat diving task is the regrouping of divers and linking up with their equipment. The following are the principles of employment for combat divers:

- a. **Centralized Control.** Combat diving assets are a limited resource; consequently they should be centrally controlled at the highest practical engineer level.
- b. **Continuity.** The Combat Diving Team most familiar with the area operations and the situation should conduct the reconnaissance and the task. Once committed to a task it may be tactically and logistically difficult to change that commitment. Continuity expedites the successful execution of combat diving operations.
- c. **Anticipation.** The regrouping of combat divers and their equipment must be done in a timely manner. Foresight and anticipation of tasks will facilitate co-ordination of this process.

708. COMBAT DIVING SAFETY

1. The most effective safety mechanism in combat diving is a proficient combat diver. The proceeding chapters of this manual detail all the pertinent safety requirements, procedures and considerations inherent to CAF diving. In addition to those related to diving, the following factors must be considered for the use of Combat Divers:

- a. The use and effects of explosives and explosive accessories,
- b. The use and effects of small arms and ammunition,
- c. Operational safety,
- d. Training safety,
- e. Operation of boats and watercraft,
- f. Operating in contaminated environments,
- g. Helicopter operations,
- h. Geographic and climatic setting,
- i. Environmental impact,
- j. The safe transportation/handling of dangerous goods, hazardous materials and weapons, and
- k. Safety support to operations and training over water. Combat divers will be tasked to provide safety support to training and possibly operations over water.

2. Safety Standby Organization

- a. B-GL-381-002, Operational Training and Training Safety, details the requirements for safety organizations.
- b. Combat divers have the capability to provide a safety standby organization in support of any type of water activity.
- c. The senior Combat Diving Supervisor, supporting the training, exercise or operation must be prepared to offer expert advice to the site commander on dive-related matters.

d. The basic organization is outlined as follows:

- (1) **Boats.** There will be a minimum of two inflatable boats and
- (2) **Diving Personnel.** It is likely that LWSSDE will be used during a standby, as this equipment will facilitate the entry into drowned vehicles/aircraft and provide the Diving Supervisor with direct control and communications with the rescue divers. This will dictate the number of divers required to support a task. Refer to [Article 120](#), *Minimum Personnel Required*.

3. **Safety Boat and Equipment**

- a. The dive safety boat will be equipped IAW standard diving safety procedures and as detailed in B-GL-381-002.
- b. Diving safety boats are detailed in [Article 126](#), Safety Boats.
- c. The equipment required in the boat is listed at [Figure 5-9](#), CAF Diving Safety Equipment Requirements.

709. **GROUP NAVIGATION CONTROL SYSTEM (GNCS)**

1. Some combat diving tasks require divers to approach an objective as a team. A GNCS may be used to achieve this. By adapting the basic concepts of underwater navigation as free-swimming pairs, a team of divers can move as a group. It must be stressed that although this technique appears simple in conception, the coordination of several pairs of divers, typically in zero visibility or beyond visibility distance of each other, is quite difficult and requires several workups to be executed safely.

- a. The basic formation consists of pairs of divers in file, with a light buoyant line extending between them. [Figure 7-4](#) illustrates the GNCS.
- b. Before GNCS can be used, all conditions at [Article 526](#), *Group Navigation Control System (GNCS) Group Swimming*, must be met.

c. **GNCS Procedure**

- (1) The lead pair of “buddied” divers acts as the primary navigators for the group. One diver navigates while the other controls the GNCS line and communicates with trailing pairs with the line.
- (2) After entering the water, the team links up, establishes the formation and descends to the planned dive depth.
- (3) While swimming, all divers are responsible for maintaining the planned depth of the dive.
- (4) A designated diver in each “buddied” pair maintains control and tension of the line.
- (5) A second pair may be designated as secondary navigator; this will likely be the last pair in the formation.
- (6) In the event that a diver has to ascend due to an emergency:
 - (a) The buddy will join in the ascent.
 - (b) The pair nearest the ascending team will be notified.
 - (c) If a pair ascends, the Team Supervisor must regroup the team and reconsider the approach; this may require aborting the dive.

- (7) In the event that a diver has to ascend due to an emergency:
 - (a) The buddy will join in the ascent.
 - (b) The pair nearest the ascending team will be notified.
 - (c) If a pair ascends, the Team Supervisor must regroup the team and reconsider the approach; this may require aborting the dive.

2. The key elements to success and safe implementation of this system are the use of the buddy system. Detailed planning, as well as the rehearsal of all procedures and possible contingencies should be conducted. All team members must be proficient in buoyancy control and have an awareness of the planned details of the dive and navigation.

3. The GNCS line will be a continuous length of buoyant nylon or polypropylene rope. It must be long enough to accommodate the team, prevent members from interfering with each other while swimming, and prevent the fouling of any towed loads. The line should be of suitable diameter to be easily visible. It should not be the same colour as the buddy-lines. Non-corrosive snap-links, Fastex buckles, or clips are spliced or fastened along the line at each pair's position. A snap link or clip is attached to each pair's buddy line, and then clipped into the group line at each respective location. Standard or prearranged rope signals will be used to communicate along a GNCS line.

4. Through-water wireless communications should be considered when using a GNCS, as they will facilitate control and passage of information; however, use of rope signals can be applied. The use of such communications devices will depend on the threat, the ability of the enemy to monitor through-water communications and the warning the enemy may have on the use of divers. Generally, an enemy threat will preclude the use of through-water communications system.

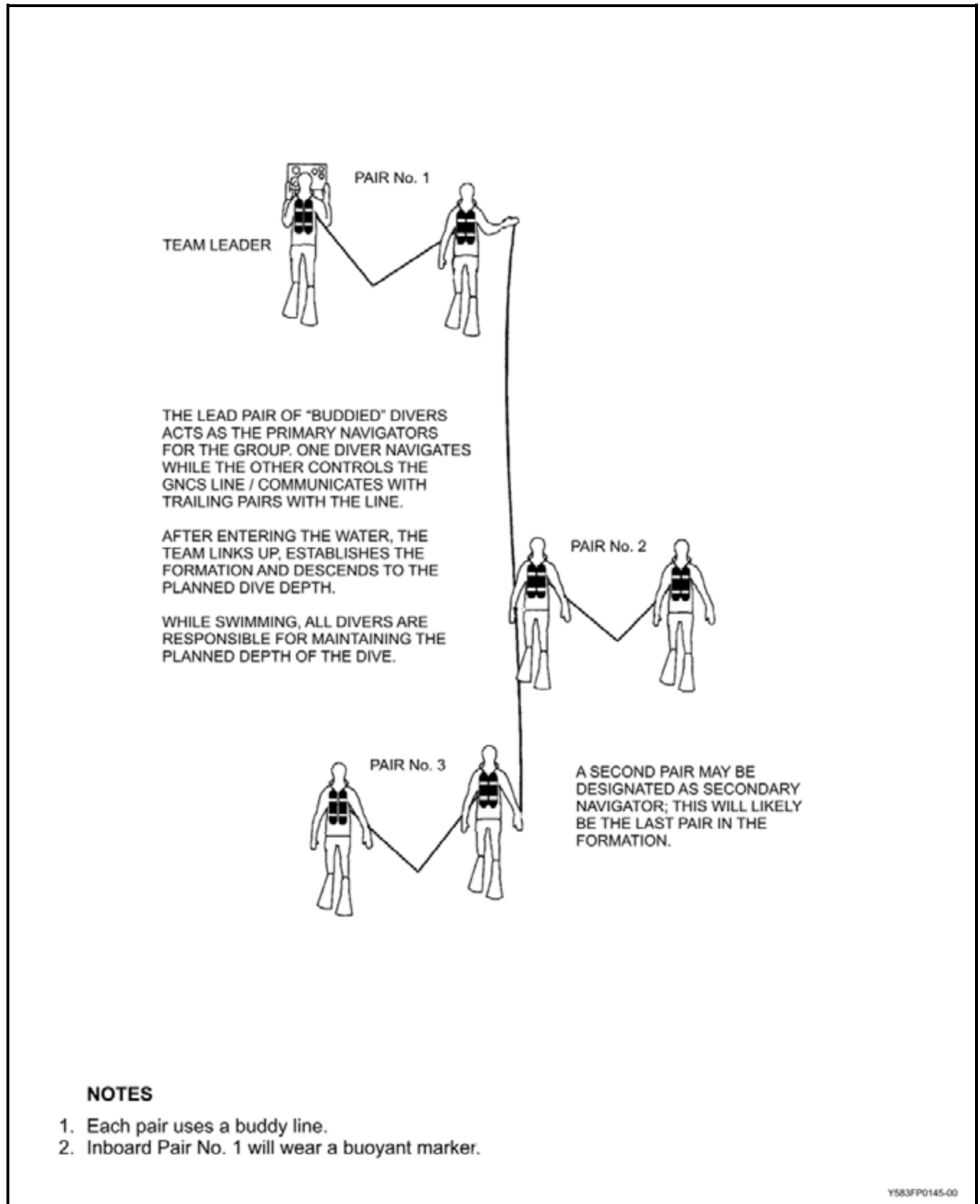

Figure 7-4 Group Navigation Control System (GNCS)

710. COMBAT DIVER TRAINING

1. Combat Divers, Supervisors and Officers receive initial and continuation training for their qualification at a Fleet Diving Unit and the ADC.
2. Collective training and maintenance of Combat Diver proficiency are functions of the LFC chain of command and the respective Field Engineer Units.
3. Course nomination and preliminary training of potential candidates is conducted at the Unit level, this allows for the most suitable candidates to be course-loaded.

711. CANDIDATE SELECTION AND EVALUATION

1. Potential candidates must meet the selection criteria stated in A-PD-055-003/PQ-001, OSS AFEP or ADUV, including completion of diving medical, dental and physical fitness test. Generally the preliminary course is conducted over a two-week period, which allows sufficient time to evaluate individual suitability and provide candidates enough time to determine their suitability for combat diving. Commanding officers have the prerogative to nominate candidates without the completion of diver preliminary training and selection.
2. As a limited number of vacancies are available for a given combat diving course serial, candidate selection is of the utmost importance.
3. The standards for physical fitness outlined in diving DAOD and CAF Fitness Standards DAODs should be considered the minimum. Candidates will be expected to exceed these standards.
4. The curriculum for the combat diver preliminary course should be based on the concept of specific adaptation to imposed demands, physically and mentally conditioning the candidate for those conditions the combat diver may experience while performing combat dive tasks.
5. Basic outline for the conduct of preliminary diver training and selection:
 - a. Aerobic endurance and strength training,
 - b. Endurance surface swims in open water and currents,
 - c. Breath-hold diving,

WARNING

Breath hold diving can be extremely dangerous if preceded by extensive hyperventilation. Refer to [Article 207](#).

- d. Black water conditions,
- e. Water entries from height,
- f. Introductory lectures on procedures, equipment, diving medicine and physics and
- g. All pre-selection evolutions utilizing CABA must be conducted under the control and supervision of ADC instructors with a minimum rank of MCpl. Candidates may be introduced to the following diving procedures within the confines of a pool:
 - (1) Clear mask,
 - (2) Swim w/snorkel and mask,

- (3) Swim w/snorkel and no mask,
- (4) Ditch and don mask,
- (5) Clear mask in full CABA,
- (6) Buddy-breath w/qualified diver, IAW [Article 221, paragraphs 1 and 2](#),
- (7) Ditch and don CABA,
- (8) Dive w/blacked out mask,
- (9) Conduct small underwater projects w/blacked-out mask,
- (10) Dive with plodding boots and
- (11) Use of underwater line signals.

NOTES

1. ADC dive instructors shall ensure that a local (on base) ADMO / ADMT is available during training and is aware of the intended training plan.
 2. Dives shall be conducted only in a controlled environment (i.e. pool) open water/river/lake assessments are not authorized.
 3. The preliminary pool testing shall be conducted only when an RCC can be reached within 4 hrs of road travel time.
 4. The RCC shall be notified and online before beginning any pool testing.
 5. The dive supervisor shall confirm travel time and method of transport between pool and RCC prior to commencing training.
 6. The fully qualified stand by diver shall be at immediate state when CBT Dvr candidates are in-water.
 7. 1:1 instructor / candidate ratio must be maintained throughout the assessment while candidates are in-water.
6. On completion of pre-selection, a written evaluation report, indicating ranking and suitability for further diver training will be promulgated.

712. CONDUCT OF COMBAT DIVER AND COMBAT DIVING SUPERVISOR'S COURSE

1. Candidates receive all formal qualification training at FDU (A) and ADC. A Combat Diving Supervisor and a Combat Diver will assist the FDU staff with course administration and by conducting and maintaining the relevant combat diver performance objectives.
2. Individual combat diver training must include conditioning and techniques that expose a candidate to the environmental conditions and stress likely encountered in the execution of tasks, with the aim of helping the combat diver adapt physically and mentally, gaining confidence and strength while making diving skills second-nature.

713. MAINTAINING CURRENCY AND PROFICIENCY

1. Combat divers must be given every opportunity to maintain currency and proficiency standards.
2. Operational tempo, career courses, posting assignments and temporary medical category may prevent a combat diver from maintaining currency. In such situations, [Figure 7-5](#) provides the guidelines and requirements to regain currency/qualification.

CRITERIA					
	Diver was Unable to Conduct a Dive Within 90 Days up to 120 Days	Last Dive Was Conducted Within 1 Year	Last Dive Was Conducted Within 2 Years	Last Dive Was Conducted Within 3 Years	Last Dive Was Conducted More Than 3 Years
Complete Rules and Regulations Review	NO see Note 4	YES	YES	NO	NO
Review Diver Signals	NO	YES	YES	NO	NO
Complete Dive Table Review	NO	YES	YES	NO	NO
Conduct Emergency Procedures Assessment in Pool or Camber Area	YES Can be open water	YES	YES	NO	NO
Conduct Open Water Emergency Procedures Dive Assessment	NO	At Dive O Discretion	YES	NO	NO
Supervise a Dive Under Supervision	NO	YES	YES	NO	NO
Waiver Request Needed	NO	NO	NO	Qualification Waiver 1 year extension Yes	N/A
Member Shall Attend Diving Requalification Course	NO	NO	Dive O Discretion	YES	NO
Co Shall Rescind Dive Qualification	IAW Vol 2	IAW Vol 2	IAW Vol 2	IAW Vol 2	YES IAW Vol 2
Member Shall Attend Diving Recertification Course	NO	NO	NO	NO	YES
NOTES					
<ol style="list-style-type: none"> Diving Requalification Course will still be required every 3 years even if the above chart table of criteria is met. Each dive team members shall complete the pre-instruction (PIP) package prior attending requalification course. CF Dive Table / Rules and Regulation review will be in accordance with A-P3-002-DST/PH-H01 Combat Diver TP, EC 001.01 and 001.04 as well as A-P3-002-DSU/PH-H01 Combat Diver Supervisor TP, PC 001 for supervisors. Dive supervisor to confirm comprehension of rules and regulations during dive brief. 					

Figure 7-5 Table of Criteria and Procedures to Follow for Combat Divers Regaining Diving Currency/Qualification

714. UNIT DIVING TEAM TRAINING

1. The skill sets required to be a combat diver require a high level of proficiency to be maintained, as such every opportunity must be exploited to allow combat divers to train as a team.
2. Unit diving team training must be integrated into the training calendar and should include combined all arms training to develop interoperability.

715. COLLECTIVE TRAINING EXERCISES

1. Regularly scheduled collective training of LFC Combat Diving Teams will standardize and develop combat diving techniques and procedures and identify evolving equipment requirements.

716. TRAINING WITH ALLIED DIVING TEAMS

1. The CLS and OPI Army Diving support and advocate the conduct of Small Unit Exchanges (SUE) between diving establishments of other nation's Armed Forces and LF diving establishments. Refer to [Article 112](#).

CHAPTER 8

STANDARD OPERATING PROCEDURES SEARCH AND RESCUE

GENERAL

801. DEFINITIONS

1. The Search and Rescue Technician (SAR Tech) Team is a primary Search and Rescue (SAR) resource. Team members are specifically trained to locate victims of air, ground or marine accidents, administer emergency medical treatment under adverse conditions and prepare survivors for and assist in survivor evacuation. Accidents in the marine environment frequently require the use of CABA for SAR Tech safety and for the effective survivor recovery.

2. This Chapter describes those CABA diving operations, regulations, qualifications and general information that pertain specifically to SAR Tech operational diving.

802. GENERAL DIVING REGULATIONS

1. The regulations, procedures, techniques and equipment common to all types of CABA diving are found in the preceding Chapters of this volume and apply to all non-rescue SAR Tech operations and to all SAR Tech diving training.

2. When SAR Tech divers conduct diving activities other than Search and Rescue diving, the special provisions and rules of this Chapter do not apply.

SAR DIVING REGULATIONS

803. SAR DIVING OPERATIONS

1. Accidents in the marine environment may require the use of CABA to enhance the safety of the SAR Tech Team and/or to assist in the effective recovery of survivors. Since these incidents would most likely occur during SAR helicopter missions and because of the urgent nature and inherent risks of these missions, orders covering SAR Tech diving operations are divided into "Rescue" and "Non-Rescue".

804. RESCUE DIVING OPERATIONS

1. SAR and humanitarian/civil-aid related distress situations in the marine environment in which there is the obvious potential for saving life are classified as Rescue Diving operations. Because of the urgent nature of these missions a two-person team may be deployed. A two-person team shall be comprised of two qualified SAR Tech divers, one of which must be a qualified QL6A Operational (OP) Team Leader (TL).

NOTE

This is the only situation in which a two-person team may be used for underwater diving operations.

2. The authority to deploy SAR Techs in a Rescue Diving situation in which there is an obvious potential for saving life shall be obtained from the Rescue Coordination Center (RCC). When authorization cannot be obtained from the RCC, the Aircraft Commander (AC), in conjunction with the TL shall assume authority. (IAW SAR aircraft SMMs). This authority is not to be confused with the decision whether or not it is safe to conduct the dive, which rests solely with the SAR Tech Team on scene.

805. NON-RESCUE DIVING OPERATIONS

1. Non-Rescue SAR rescue diving operations are those which do not have as their primary aim the saving of human life as part of a SAR operational tasking. They may include:
 - a. Identification of underwater wreckage including downed military aircraft;
 - b. General Service Diving in support to CAF installations, bases, wings or units; and
 - c. Humanitarian/civil-aid category incidents where diving assistance is requested by civil authorities through Regional Operations and where there are no other divers available.
2. All diving regulations as contained in B-GG-380-000/FP-002 shall be strictly adhered to in non-emergency rescue diving operations.
3. Authority to conduct non-emergency rescue diving operations shall be obtained from the following:
 - a. For SAR-related cases: RCC/Searchmaster.
 - b. For non-SAR (humanitarian/civil-aid) cases: Regional operations through RCC/Search Master.
 - c. For military operations: Through the Dive Safety Officer, normally the SAR Tech Leader advises the Commanding Officer.
4. Concurrence of the squadron Commanding Officer is required for all non-rescue diving operations. RCC will normally provide the co-ordination and vital communications link for all diving related missions.
5. SAR Techs are not normally to be tasked to dive for salvage or for the recovery of human remains.

806. CABA RESCUE DIVING AND CSRD OPERATIONS, SAR

1. SAR Tech diving procedures are detailed in this publication and further amplified in the RCAF FOM and SAR aircraft SMMs. [Annex A-8](#) contains the SOPs for Confined Space Rescue Diving Operations and [Annex B-8](#) contains the Safe Training Practices for CSRD.
2. The following procedures shall be followed when SAR helicopters that are engaged in Rescue Diving operations for SAR operations. A minimum of two qualified divers is mandatory for Rescue Diving operations from SAR helicopters with one of the divers being a qualified QL6A Op TL. Deployment of the SAR Techs shall be conducted as follows:
 - a. SAR Techs shall dress for the operation in accordance with [Annex A-8](#).
 - b. Dive weights SHALL only be used for Rescue Diving or CSRD Operations.
3. During operational or training water hoists/surface operations, the 30 cu/ft bottle may be used as a breathing medium with the following restrictions:
 - a. Sub-surface operations not authorized, surface swimming only;
 - b. Weights not worn; and
 - c. Personal flotation devices to be worn.

807. CONFINED SPACE RESCUE DIVING PROCEDURES

1. The SOPs for Survivor Extraction during Confined Space Rescue Diving are issued on authority of 1 Cdn Air Div HQ Winnipeg / SO SAR Tech.
2. [Annex A-8](#) is the principal reference document governing the conduct of all SAR Tech Confined Space Rescue Diving for Survivor Extraction.
3. The Dive Team always has the option to refuse to dive.

808. SAR TECH SAFE TRAINING PRACTICES

1. SAR Tech safe training practices are detailed in [Annex B-8](#) as well as the RCAF Flight Operation Manual (FOM).
2. **Diving Limitations.** The following limitations shall apply to training dives conducted by SAR Tech divers:
 - a. SAR Tech divers shall not exceed a maximum depth of 30 metres.
 - b. SAR Tech CABA equipped divers, while carrying out free entries from helicopters, shall be restricted to a height not exceeding three metres above water level and to a speed not exceeding five knots.
3. **Standby Diver**
 - a. A qualified standby diver shall be at IMMEDIATE NOTICE IAW [Article 108](#) during all Capsized Vessel training.
 - b. For Rescue Diving operations, the standby diver, **if available**, will be at IMMEDIATE NOTICE IAW [Article 108](#).
 - c. For all other CABA training, the Diving Supervisor will specify the state of readiness of the standby diver IAW [Article 108](#).
4. **Minimum Personnel Required.** The following regulations shall apply regarding the minimum number of required personnel during dive operations:
 - a. During Rescue Diving operations, a minimum of two qualified SAR Tech divers are mandatory for CABA operations with one of the divers being a qualified QL6A Op TL.
 - b. During Non-Rescue Diving operations, the rules found in [Article 120](#) will be followed.
 - c. During CSRD training, the minimum number personal required to conduct training is outlined in [Annex B-8](#).
5. **Free-Swimming**
 - a. Due to the complexity of the task, the risks involved, and urgent nature of survivor extraction, free swimming in pairs with or without a buddy line and free swimming solo is authorized for SAR Rescue Diving operations. SAR Techs are to consider free-swimming only as a last resort when the risk of entanglement or other hazards outweighs the use of buddy line. Free-swimming should never be considered routine or a preferred method to conduct Rescue Diving operations.
 - b. For all other free-swimming rules, refer to [Article 121](#).
6. **SAR Tech Dive Currency Requirements**
 - a. To remain operationally current, SAR Techs shall maintain the following minimum dive quarterly, semi-annual and annual currencies:

- (1) Rotary-wing
 - (a) **90 Days.** One CABA dive.
 - (b) **180 Days.** One open water CABA dive.
 - (c) **Annually.** CABA proficiency check.
- b. CABA training shall include one dive every 90 days. However, the SAR Tech diver should participate in six diving cycles in this period. A diving cycle includes all aspect of diving evolution such as pre-dive preparations, dive brief, conduct of the dive, post-dive maintenance, and debrief.
- c. A CABA helicopter entry may constitute a 90-day CABA currency dive with entries into the CAFDITS (Canadian Armed Forces Diver Information Tracking System) CAF 849 and the CAF 850 Divers log for a depth of 3-metre and 2 minutes total time.

NOTE

This SHALL not be used consecutively to meet the 90 day currency.

- d. Swimming pool dives may constitute a currency dive for Units that are restricted due to temperature and/or ice conditions; however, an open-water dive shall be conducted every 180 days. A CABA helicopter entry will not be counted towards the 180 days open water currency.
- e. In addition to currencies outlined above, SAR Techs shall successfully complete Proficiency Check Flights when administered and the SAR Tech Physical Fitness Test annually.
- f. If CABA currency lapses, a SAR Tech is operationally RESTRICTED. IOT regains operational status, the diver SHALL follow all procedures found in the RCAF Fight Operations Manual (FOM).

NOTE

The SAR Tech can conduct training flights that do not require diving.

- g. Requests for extension or waiver of any currency/proficiency requirement will be in accordance with the RCAF FOM.
 - h. Non-SAR Tech divers attached to SAR Unit dive teams SHALL follow rules and regulations applicable to their particular dive qualification listed in the B-GG-380-000/FP-002 and or all other applicable references.
7. **Continuation Training.** The following should be included in field and air training exercises as part of the SAR Tech Continuation Training Program:

a. **Air Training**

- (1) Hoists – guideline, boat, land, water, CABA Ensemble and double-hoist procedures.
- (2) Free and CABA helo entries.

- b. Open-book exams containing questions on diving shall be administered semi-annually, with a closed book exam containing dive questions administered annually.

8. **CABA Diving Administration.** As per B-GG-380-000/FP-002, [Chapter 1, Administration and Medical Records](#) Section.

9. **References**

- a. SMM 60-130-2605 (SAR),

- b. SMM 60-149 (Cormorant),
- c. SMM B-GA-002-146/FP-001 (Griffon),
- d. SMM 60-115-1003 (Buffalo).

809. CURRENCY REQUIREMENTS, SAR

- 1. SAR Tech currency requirements are detailed in the RCAF FOM.

810. SAR TECH RENTAL OF NON-SERVICE DIVING EQUIPMENT

- 1. Rental of non-service equipment is authorized for SAR Techs to carry out operational SAR taskings IAW [Article 804](#).
- 2. Only equipment not normally carried by SAR Techs in their personal dive standby kits may be rented (e.g. cylinders, weight belts and weights).
- 3. [Article 136, paragraph 3](#) is to be followed for all planned training where non-service CABA cylinders are intended to be used by the SAR Tech dive team.

ANNEX A8**CONFINED SPACE RESCUE DIVING FOR SURVIVOR EXTRACTION****SECTION 1****CSRD OPERATIONS GENERAL****1.1 – INTRODUCTION****1.1.1. GENERAL**

1. These Standard Operating Procedures **MUST** be read in conjunction with The Guidelines for Survivor Extraction from Capsized Vessels. The Guideline contains in-depth technical details used to support this document.

1.1.2. TERMINOLOGY

1. Key words used in this document have the following meanings:

- a. “Shall”, used to indicate a requirement;
- b. “Will”, used to indicate an intention or proposal;
- c. “May possible”, used to convey that something is permissible or possible;
- d. “Should”, used to convey a technique or action that is recommended but not mandatory;
- e. “WARNING”, used to emphasize an operating or maintenance procedure, practice, condition or statement, which, if not strictly observed, could result in injury or death of personnel;
- f. “CAUTION” used to emphasize an operating or maintenance procedure, practice, condition or statement, which, if not strictly observed, could result in damage to or destruction of equipment, loss of mission effectiveness or long term health hazards to personnel; and
- g. “NOTE” used when it is desirable to highlight a procedure, event or practice.

1.1.3. INTRODUCTION

1. These SOPs were developed utilizing the Search and Rescue Technician's (SAR Tech) Guidelines for Survivor Extraction from Overturned Vessels (1 CAD/TRSET Directive 2004). Change 3 2005-04-19 was the most current edition, up until resumption of CSRD training at CFSSAR Dec 2014.

2. Every SAR diving situation is different especially when conducting Survivor Extraction. It poses its own unique set of problems that must be taken into consideration by the SAR Tech dive team. It is realized that some modification will be necessary once the dive team is in location and had an opportunity to survey the situation. These SOPs are not intended to take away from the training and experience of the dive team. The dive team must weigh all factors they are faced in order to execute the safest rescue dive plan.

3. Operational 2 person SAR Diving is divided into two separate categories:

4. Rescue Diving (RD)- Classified as diving in support of SAR Operations with the possibility to save life and there is no confined space, or low risk of entanglement; and

5. Confined Space Rescue Diving (CSRD)- Classified as a more complex diving scenario that will require a SAR Diver to enter into a confined space in order to save a life. This entails greater levels of risk to the diver while conducting the rescue. This classification of diving due to the complexity and risk to the dive team, shall be surface supported in the conduct of this Rescue Operation phase of the dive.

6. The following considerations are not all inclusive; however, they provide the SAR Tech dive team with options, and a procedure in which to start initial planning for a possible CSRD;

- a. The submergence survival time will guide Team Leader's (TL's) decision to determine if there is reason to believe that survivors still exist;
- b. Is there is a high probability of locating survivors. (size of vessel and complexity of layout);
- c. Dive team is able to ensure the dive site is safe, i.e. buoyancy/stability of the structure being entered, debris in the water or entanglement hazards in the dive site vicinity; and
- d. Can the dive be completed reasonably with a two person SAR Tech dive team.

THE DIVE TEAM ALWAYS HAS THE OPTION TO REFUSE TO DIVE

1.1.4. PERSONNAL EQUIPMENT

1. Although mandatory equipment for CSRD is ever evolving, the current CAF in service dive equipment is all that is available until a purpose built CSRD ensemble is procured. SAR Tech Rescue dive teams involved in CSRD operation will wear and utilize the following mandatory equipment:

- a. SAR Tech dry suit with appropriate underwear, gloves and hood;
- b. Buoyancy Compensator (BC), waist knife, whistle, dive light, spare mask, strobe light, and securing lanyards (para cord);
- c. Flash light;
- d. Dive knife (lower leg);
- e. Fins;
- f. VHF/FM radio, left on the surface vessel once dive ops commence; and
- g. Day Night Flare.

1.1.5. STANDBY DIVE EQUIPMENT

1. The following gear is considered to be the minimum gear required to constitute an Ops CSRD kit. It can be carried on AC depending on unit area of responsibility (AOR) or held in the SAR TECH section pre-packed and ready to be loaded onto the standby aircraft as required.

- a. 2- Dive cylinders (more cylinders may be req'd depending on the situation);
- b. 2- Survivor Auxiliary Air Containers (SAAC) complete. This includes two 13 cu ft pony bottles with SAAC containers and 2 single whip regulators. (More cylinders may be req'd depending on the situation), two half masks and 2 x wrist / arm mounted glow-stick and tieback keepers;
- c. 2- 200 ft Detachable guidelines on dive reels;
- d. 1- MK-7 BUDDY-LINE hard-wire system communication system complete. This includes: 1 x communication box with head set and -2 x Communication lines (100' or 150') - 1 for each diver, 1 x Orange securing bag for hardline communication box and Dielectric grease;

NOTES

1. Each divers comms line must be equal in length with the other. If it is 100' then both need to be 100' and similarly with the 150' comms lines.
 2. TRSET to standardize Comm / Lifeline lengths at a future date at which time a DGM will be promulgated.
- e. 2- AGA Masks fitted with Gill Valve, comms ear/mouth pieces, attached to the first stage regulator AGA whip, (may be fitted with hands free lights);
 - f. pressure gauge console able to accommodate digital depth gauge/ bottom timer, and compass);
 - g. Pinch bar;
 - h. 1- Spare parts kit;
 - i. 2- Medical scissors;
 - j. 1- Grease pencil;
 - k. 4x Internal weight pockets full of weights (remove weight as required);
 - l. 1x Dive Supervisor Handbook;
 - m. 1- Roll gun tape;
 - n. 8- Chemical lights 12 hrs;
 - o. 1- Mini hand held depth sounder;
 - p. 6- Non-locking carabineers;
 - q. 2- CSRD Extraction buddy lines;
 - r. 1- Waterproof, rugged case to use for possible aerial delivery or hoisting; and
 - s. 2- 2000 Lumen Flashlights.

SECTION 2

CSRD OPERATIONS DIVING PROCEDURES

2.1 – INTRODUCTION

2.1.1. PRE LAUNCH

1. Obtaining on scene information in the prelaunch stage will assist the TL to determine if a CSRD is likely. On scene conditions, personnel, and equipment should be gathered by RCC from the persons on scene and relayed to the TL:

- a. Time of Incident;
- b. Stricken vessel type / position / number of pers on board;
- c. Number persons unaccounted for;
- d. How is vessel floating (upside down, bow up, stern up etc);
- e. Cause of capsized (sea state, collision, taking on water);
- f. Hull damage;
- g. Sea state / depth / tide / temp / current / wind strength; and
- h. Appropriate support vessel on scene / size / mobility / comms.

2. If a CSRD is suspected request a backup SAR Tech dive team from RCC. If the preferred SAR Tech dive team is not available consider the following listed in the NOTES below and in the following order of preference:

NOTES

1. DND clearance divers (may not be trained in survivor extraction);
2. RCMP or other police dive team (may not be trained in survivor extraction);
3. COAST GUARD dive team (West coast); and
4. Commercial divers (may not be trained in survivor extraction).

NOTE

If a backup dive team is not immediately available request re-supply of filled dive tanks from the nearest available source and or take as many extra as practicable. Expect a delay in response time, as most of the above resources do not have immediate access to transportation that will get their team to the site

3. Ensure VTS (vessel traffic system) demands a “slow bell” (minimum wake from passing vessels, (channel 11 or 12) and that Coast Guard Radio broadcasts a request for minimum wake in the area on channel 16.

4. Request large vessels for stabilizing the capsized vessel.

5. Have first unit/pers on scene pound on hull to see if there are conscious survivors inside, and then search surrounding water for escaped survivors. Instruct the first unit on scene, not to cut a hole in the hull.

2.1.2. SAR DIVER PREPARATIONS-ON ROUTE

1. CSRD extraction of survivors is time sensitive and efficiency of the execution is paramount. On route preparation time can be limited and requires specific equipment.
 - a. Prepare medical equipment - Oxygen, suction, airways, AED, stretchers, bag & mask, electric blankets, advance casualty care equipment;
 - b. Package the dive equipment for aerial delivery or hoist as required;
 - c. Ready divers personal equipment;
 - d. Prior to insertion complete final safety checks confirming insertion plan to the support vessel of personal and equipment; and
 - e. Confirm communications plan with aircraft, surface to AC.

2.1.3. ON SCENE INITIAL ASSESSMENT & INITIAL ENTRY CONDIDERATIONS

1. The decision to dive shall include the following factors:
 - a. The Dive Team SHALL get a response back from inside the vessel to continue the rescue effort. The team must be positive that there is a life to save before proceeding with a Dive;
 - b. Ensure request for available dive team assets through RCC and if available consider their ETA into your initial dive team plan;
 - c. Have all available info before initiating dive. I.e. number of POB, their last known position, and as much info regarding vessel layout;
 - d. Assess Vessel Stability:
 - (1) Is it stable;
 - (2) Is it properly secured;
 - (3) Assess Sea State, current;
 - (4) Depth of the water and direction of drift i.e. will it run aground; and while the dive team is diving.
 - e. Ensure the dive team approaches from upwind and up current (less debris, fuel, less tiring).

2.1.4. SURFACE SUPPORT/PLATFORM SETUP

1. Appropriate surface support to include, but not be limited to; boats, barges, docks and shorelines along with surface personnel in support to assist divers and tend lines. Surface support shall be of sufficient size and configuration to accommodate all divers and their equipment in conjunction with the on-scene environmental conditions.
 - a. Clear area for tending / entry point;
 - b. Each space will be different;
 - c. Each platform will be different (ensure props or intakes / outlets will not interfere or be a hazard to the dive team and or their tended lines);
 - d. Connect comms & secure comm lines to the surface vessel;

- e. Perform a comms check;
- f. Brief tenders, on appropriate comms procedures / safety concerns and ensure they know which diver they are tending; and
- g. Have a plan established for the surface support personnel to assist in pulling out any survivors or victims extricated from the vessel. i.e. Par-buckling or mechanical lift.

2.1.5. INITIAL ENTRY PROCEDURES

- a. Upon entry into the water, the dive team must conduct a leak check between both divers;
- b. SHALL attach CRSD buddy line to entry diver's comm line / safety line as required;
- c. Tending diver manages entry divers line in conjunction with the surface tender;
- d. Entry diver begins to pound on hull & listen if already not completed on the surface. (Use butt end of dive knife);
- e. If possible, scribe a line on the hull at the waterline or establish a physical reference to note the waterline on the hull if not already completed on surface;
- f. Tending diver manages lines, watching out for hazards, boat movements;
- g. Once pounding heard and the survey is completed of the vessel / structure, a decision may be made to enter the vessel / structure; and
- h. The rule of thirds shall always be applied in the CSRD environment, a third in, a third out, and a third in reserve.

2.1.6. ENTRY DIVER

- 1. It is important for the entry diver to give a constant description on what he/she is seeing and doing.
 - a. Confirm their BAR with their dive partner;
 - b. Dive down to find entrance and secure it, tie back any debris that is in the way or possible hazard; and
 - c. Entry diver will reconfirm BAR with tending diver before entering the vessel / structure.

2.1.7. TENDING DIVER

- 1. The tending diver may descend below the surface if the sea state is rough.

Their duties are as follows:

- a. Remind the entry diver to give BAR updates every 5 minutes;
- b. Maintain watch on vessel waterline as scribed, marked or physically referenced on the hull;
- c. If required, reassuringly communicate with entry diver to help keep him/her calm; and
- d. Ensure the entry point is clear.

2.1.8. ENTRY DIVER

Their duties are as follows:

- a. Remain calm throughout the dive;
- b. Move slowly and methodically to prevent entanglements;
- c. Clear debris / entanglement hazards from their path as best able; and
- d. Keep a running dialogue with the tending diver to keep him / her informed of the situation and their progress.

2.1.9. ENTERING THE SURVIVOR'S COMPARTMENT

1. SAR divers SHALL not remove their own facemask and regulators inside air pockets, as fuel ingestion is probably inevitable which will compromise diver safety.

- a. Entry diver should release a chem light as a warning to the victim;
- b. Surface slowly away from the chem light if possible; and
- c. Ensure a thorough search of the compartment is completed

2.1.10. EXTRACTING SURVIVORS

- a. The entry diver should never remove their mask in the air pocket;
- b. The entry diver should speak in a reassuring tone with the AGA mask completely out of the water if possible;
- c. Ask these questions;
 - (1) Are you alone? If not,
 - (2) Where did you see them last?
 - (3) Can you swim?
 - (4) Have you ever scuba dived before?
- d. Explain egress procedure;
- e. Attach SAAC to survivor placing the half mask on survivors face;
- f. Have them practice breathing under water for a short time;
- g. Encourage the survivor to breathe normally and controlled throughout; and
- h. Let the survivor know that there will be another diver waiting at the vessel entry point.

NOTE**EXTRACTION POINTS TO CONSIDER**

1. Remember BAR/PSI checks & limit for entry (rule of thirds);

2. Keep talking to the survivor, over explaining is better than being silent;
3. If the survivor is panicked use life guard position;
4. Explain to the survivor to not hold their breath, in order to prevent a possible air embolism;
5. Prepositioning the tending diver for the survivor extraction; and
6. Every person / situation is different and must be treated as so.

Do the best you can!

2.1.11 IF THE SURVIVOR IS UNCONSCIOUS

- a. Keep the survivor's mouth closed using the Head Sandwich technique.
- b. The entry diver may require extra assistance from the tending diver.

NOTE

Deceased victims should only be extracted if all savable have been extracted first and it is safe, not causing increased undue risk to the dive team to do so.

2.1.12. TENDING DIVER

- a. Continue to ask entry diver for BAR / PSI updates and route description (if not doing so);
- b. Remind surface tenders to keep slack out of the lines, but not fight the divers progress (if required);
- c. Watch water line and any changes in vessel stability or position in the water; and
- d. Be prepared to assist the entry diver with the extraction of survivors at the entry point.

2.1.13. ENTRY DIVER

- a. Inform the tending diver that you are heading out with a survivor;
- b. Inform the tending diver to meet you at the entry point; and
- c. Do not let survivor rocket to surface unattended ensuring a controlled ascent and normal breathing / exhalation of the survivor.

2.1.14. MULTI-VICTIM EXTRICATION

1. In the event of a Multi-victim extraction it is imperative to understand the dive team is a rescue asset not recovery. Water temperature and time to on scene are factors if unconscious victims will be extricated.

- a. Utilize the same entry procedures as before;
- b. Save the savable first and foremost, in the following order; and
 - (1) Conscious;
 - (2) Unconscious;
 - (3) Deceased.

- c. Utilize the same procedures as in a single man extraction.

NOTE

Utilizing a reel is an option. Vessel layout should determine the necessity to use a reel. Start by tying the anchor end off at the entry point.

SECTION 3

CSRD OPERATIONS DIVING PLATFORMS

3.1 – INTRODUCTION

3.1.1. INTRODUCTION

1. This chapter describes launching and preparing for CSRD operations from different platforms and aircraft. Unit area of operations aircraft platforms will dictate best rescue practices. General information is held in this chapter.

3.1.2. PLANNED OPERATIONS FROM SURFACE SUPPORT VESSEL

- a. SAR Techs hoist or parachute to an appropriate support vessel with required equipment;
- b. Review communication procedure with all involved personnel; and
- c. Select crewmembers to assist in the dive operation where they can best be utilized. (Assisting in tending from platform, standing by to pull survivor out of the water). Ensure proper brief is given on duties expected.

3.1.3. PLANNED OPERATIONS FROM SAR HELICOPTER

1. The SAR Tech Team Leader (TL) will determine the insertion method based on the conditions found on scene. The TL should remember that no lines or ropes are to be attached to the diver when jumping from an elevated platform.

- a. Divers dress complete, with air turned on minus AGA mask. Complete safety checks on each other. Don AGA mask and perform final safety check before exiting via free entry or hoist from the helicopter;
- b. When the SAR Techs exit the helicopter, they place one hand over the facemask, while the other hand supports the diving cylinder to prevent it from rising during the water entry. On departing the helicopter, avoid jumping so as not to strike the regulator on the door frame. The SAR Techs enter the water in an upright position. When two or more personnel exit the helicopter, they shall allow sufficient time/space between individual exits to ensure the safety of all personnel. However, the exits should still be performed as a two-man stick;
- c. When SAR Techs have exited the helicopter and prior to carrying out CABA operations, they ensure that the visual “thumbs up” signal is given to the FE. The signal indicates that they are in good condition and are beginning the diving operation;
- d. Divers approach the vessel in a normal manner preferably up wind/up current, while remaining clear of any fuel/oil slick;
- e. Divers can conduct an initial recce if support vessel is on-route or prior to boarding the surface vessel;

2. Establish and maintain comms from the surface vessel to helicopter by utilizing the VHF/FM radio. Request passive information and bingo fuel updates while CSRD operations are in progress.

NOTE

The helicopter should depart the immediate vicinity of the CSRD (high noise levels only add to on scene confusion), remaining approximately 500 - 1000 meters away from dive scene as required.

3.1.4. PLANNED OPERATIONS FROM SAR FIXED WING

1. Surface vessel SHALL be on scene and have mobility to recover equipment and SAR Techs. Water para and aerial delivery of equipment procedures are detailed in aircraft SMMs.

- a. To prevent damage to the CRSD equipment, careful packaging in hard shelled, waterproof cases must be considered;
- b. Surface vessel SHALL be warned of prop entanglement hazards when recovering equipment and parachutists;
- c. SAR Techs should land away from the stricken vessel due to contaminated water. Fuel cannot be seen in parachute descent;
- d. Establish and maintain comms from the surface vessel. Ask for passive information and bingo fuel updates while CSRD operations are in progress; and
- e. Once equipment and personnel have been collected, CSRD operations can commence.

SECTION 4

CSRD OPERATIONS EMERGENCY DIVING PROCEDURES

4.1 – INTRODUCTION

4.1.1. EMERGENCY CONTINGENCIES FOR ENTRAPMENT

1. If a diver becomes entrapped in a compartment in the capsized vessel by a hatch or door closing behind him, he should inform the surface and the other diver will assist from the outside with tools at hand (pinch bar, knives, screwdrivers, etc).
2. If unable to free the diver, consider the following:
 - a. Through RCC, request additional resources, DND clearance divers or commercial salvage divers. Advise them of the boat's construction. (i.e.: steel, wood, fiberglass);
 - b. Check on ETA of equipment and back up dive team as previously arranged;
 - c. Have RCC check nearest fire halls for Fire Department Extraction Equipment (i.e.: hand or power operated "jaws of life," partner saws, chain saws, hydraulic extraction devices);
 - d. Have RCC arrange transport of equipment and personnel familiar with its use. Hand operated equipment can be used underwater;
 - e. Arrange for more air tanks for the trapped diver and work out a method of supplying air (may be able to pass 2nd stage regulator through a small opening); and
 - f. Consider towing capsized vessel to shallow water and grounding it so that a chain saw (wood or fiberglass) or partner saw (steel boat) may be used to cut an opening without danger of sinking the vessel. Watch for fuel tank placement when cutting.
 - g. If the diver becomes entrapped due to the drifting vessel running aground. Consider rolling boat over with a towline. Requisition help on channel 16 from a nearby suitable vessel to use as a towboat (small tug, fish boat, CCG Cutter). Decide the best way to roll the boat, usually down slope and with the current. Attach a towline to the opposite gunwale, right amidships over the keel. If the vessel is on the bottom in shallow water this may be done by the 2nd diver hooking an anchor under the gunwale, if there are no suitable strong points right amidships. The anchor should be secured with a line to keep it from sliding off as the towboat takes up the strain. If the vessel is completely submerged the diver should note the compass bearing orientation of the vessel and inform the surface. Have the towing vessel pull perpendicular to the capsized vessel's keel for a short distance.

4.1.2. DISORIENTATION

1. Compartmented steel vessels (tugs, seiners, etc.) will tend to have more complex interior layouts, especially military or decommissioned military vessels. If diver becomes disoriented in the capsized vessel, consider the following:
 - a. Turn upside down and "stand" on the deck. This may help in visualizing the layout of the boat and where to go next.
 - b. Follow lifeline out until reoriented. This may be the only option in zero visibility conditions.
 - c. In all cases advise surface and the Tending diver

4.1.3. CAPSIZED VESSEL SINKING

1. This may not be apparent to the diver in the capsized vessel. The dive tender on the surface as well as the tending diver must keep an eye on the waterline level of the capsized vessel and inform the diver(s) of any changes.
2. If communication circuit fails the following signals shall be used:

AIR ESCAPING -RAPID POUNDING ON HULL- GET OUT “IMMEDIATELY”

3. The Tender is to wait until the Entry Diver is out of the vessel then both divers ascend together to the surface. Divers must disconnect from lifelines if they are hampered in anyway by the line while escaping from the vessel.

4.1.4. AIR SUPPLY FAILURE

- a. Advise surface and Tender immediately, switch to secondary air source (SAAC if available);
- b. Follow lifeline and proceed to main exit point; and
- c. Tender to immediately follow lifeline and provide secondary air source regulator and mask.

4.1.5. ENTANGLEMENT

1. Diver entanglement can lead to full entrapment. Remaining calm and assessing the situation for best course of action will save time and air resources and hopefully prevent a worsening of the situation;
 - a. A diver's knife is very poor tool for cutting monofilament line. Scissors or specially designed line cutters are the most effective tools for this situation. The diver should not struggle, as this often worsens the situation. He should advise the Tender he is tangled and will first try to free himself;
 - b. If the anchor point of the line or net is below the diver, gain a little positive buoyancy in order to tension the line or net before attempting to cut it. If anchor point is above the diver, gain a little negative buoyancy; and
 - c. If unable to free, call the Tender for assistance or if voice comms fail, use 2-2-2 pulls on the diver lifeline.

4.1.6. SURVIVOR PANIC

1. If a survivor is panicking in the air pocket, take out stable survivors first. Reassure the survivor the best that you can. A full explanation of what the survivor is going to experience may calm them down. Consider bringing in the Tending diver to assist in the extraction.
2. If the survivor panics during extraction, use lifeguard techniques. The best position to be in is behind and slightly below the survivor, so they cannot reach the divers mask/regulator. If the entry diver is pulling the survivor from the vessel, the Tending Diver should be ready to assist.

4.1.7. OTHER CONSIDERATIONS

1. In zero visibility conditions, proper site evaluation and history of the incident will help determine whether to dive or not. Zero visibility diving should only be attempted when the dive team has determined the risk is acceptable, using parameters including but not limited to:
 - a. No gillnets;
 - b. No drifting debris (ice, logs, partially buoyant vehicles, etc);

- c. No currents;
- d. The divers ability to cope with the situation;
- e. Depth;
- f. History of the case; and
- g. Vessel traffic encountered; and
- h. Log booms.

4.1.8. COMMUNICATIONS FAILURE

1. The use of voice communicating systems will alleviate the tendency for the diver to feel alone. Diver panic can increase air consumption and possibly cause a diving emergency. Alternate means of communicating must be understood by the dive team. Depending on the CSRD situation the Dive team should give serious consideration to aborting the dive in the event of a comms failure.

2. In the event of a communication system failure, the first step where no voice alternative exists is to attract the attention of the other diver. Rapping on a tank or waving a light slowly up and down are attention-getting signals. A rapid side-to-side light motion or strobe activation is considered an emergency signal (Something is wrong). Once a diver has the attention of the other diver, standard hand signals may be used by shining their dive light on their free hand. Alternately bells and pulls are to be utilized with the lifeline.

- a. 2-2-2 pulls - I am fouled and require assistance.

WARNING

Do Not Use Diver Recalls (Thunder flashes) or Day Night flares. There may be large amounts of fuel in the immediate area of the capsized vessel, which could ignite if a Diver Recall or Day Night flare were to be used.

4.1.9. NIGHT CSRD OPERATIONS

1. Night diving operations may present the diver with more stress and anxiety than encountered in a similar daylight environment. Managing this stress when it is experienced is essential to safe and effective night dive operations.

2. With the exception of additional lighting, night diving dress does not vary significantly from standard SAR TECH diver dress. However, due to the reduced visibility it is important to ensure alternate air sources are clearly identifiable. All instrumentation; compass, timer, depth gauge, and pressure gauge should be luminous/illuminated for easy reading. A whistle should be attached to the divers stab jacket. It will act as a redundant surface communication method in the event of diver separation in conjunction with the strobe. Divers should carry a backup dive light securely fastened to them. Chemical light sticks are useful in night diving operations. They can be used for marking ascent/decend lines, diver's position, and entrances to confined spaces, etc.

3. Visual references for diver orientation may be more difficult to maintain in the limited lighting offered by the divers light. For this reason, descent & ascent should be conducted with the aid of a "reference line" when operations permit. Anchor lines or lines from marker buoys are well suited for this purpose, and will be available aboard most surface support vessels.

4. Dive site illumination (0-40 ft depth) may be effectively enhanced by having surface vessel direct their searchlight onto the surface.

ANNEX B8

SAFE TRAINING PRACTICES FOR CONFINED SPACE RESCUE DIVING (CSRD) TRAINING

INTRODUCTION

1. These training guidelines were developed utilizing the Search and Rescue Technician's (SAR Tech) Guidelines for Survivor Extraction from Overturned Vessels (1 CAD/TRSET Directive 2004). Change 3, 2005-04-19, was the most current edition, until resumption of CSRD training at CFSSAR Dec 2014. These CSRD training guidelines are also available on the 1 CAD/TRSET Share Point site under the SAR Tech/Standards/SAR Rescue Diving-CSRD Standards headings.

NOTE

Utilization of the standardized Mission Approval and Launch Authority (MALA) process for diving, may be helpful for the dive team to fully identify the risks involved not only in operations but also in the planning of dive training.

2. The CSRD training guidelines are to be utilized in conjunction with the operational CSRD SOPs, but have some differences as SAR Tech dive teams will have to follow all applicable diving regulations as outlined in previous chapters of the B-GG-380-Vol 2 for dive training.

- a. CFSSAR, utilizing "Lessons Learned", adopted these safe training practices to mitigate the inherent hazards of CSRD in the training environment and as such;
- b. These safe training practices **SHALL** be followed by all SAR Tech diving teams conducting CSRD training at CFSSAR or while conducting unit CSRD training at home or at another unit's location.
- c. CSRD Training Dives SHALL be conducted from an appropriate surface support vessel / platform.

NOTE

Surface support to include, but not be limited to; boats, barges, docks and shorelines along with surface personnel in support to assist divers and tend lines. (As per CSRD SOP's, Planned Operations from Surface Support Vessel, [2.1.4](#), pages 8A-5 and 6 and [3.1.2](#) page 8A-10.

- d. As dive training is conducted in an ever changing environment, lessons learned have provided insight to evolve the acceptable parameters surrounding CSRD safe training practices. The following guidelines **SHALL** be strictly enforced while conducting CSRD training;
 - (1) In Clear visibility – Defined as visibility unimpeded by turbidity where the ability to see is no less than 5 metres;
 - (a) The DTV SHALL be positioned offset of the surface platform at a 45 degree angle to allow maximum access to all sides.
 - (b) Supervisor:
 - i. SHALL be a SAR Tech Dive Supervisor who has completed the CSRD training and is a current SAR Tech diver / supervisor.
 - ii. SHALL only supervise one pair of divers at a time.
 - iii. SHALL ensure the headset is monitored and voice communications are maintained with the dive team at all times.

- iv. SHALL review the CSRD emergency procedures / SOP's prior to the days training.
 - v. SHALL brief the divers on training goals and diver emergency procedures.
- (c) Live casualty used who is:
- i. An operational SAR Tech / QL5A SAR Tech Diver.
 - ii. Is familiar with the DTV and its emergency exits / procedures.
 - iii. Wearing a 30 cu/ft pony bottle with ½ mask.
- (d) Standby Diver SHALL be:
- i. Dressed at the immediate (CABA).
 - ii. Tended (tender briefed by the dive supervisor).
 - iii. On the surface platform.
- (e) SAR Tech 2 Man Dive Team SHALL be:
- i. Dressed as per the SOP's for CSRD diving.
 - ii. Individually tended from the surface (tenders SHALL be briefed on their duties by the dive supervisor).
- (2) In Limited visibility – Defined as visibility impeded by turbidity where the ability to see is between 5 and 1 metres;
- (a) DTV SHALL be positioned offset of the surface platform at a 45 degree angle to allow maximum access to all sides.
- (b) Supervisor:
- i. SHALL be a SAR Tech Dive Supervisor who has completed the CSRD training and is current as a SAR Tech diver / supervisor.
 - ii. SHALL only supervise one pair of divers at a time.
 - iii. SHALL ensure the headset is monitored and voice communications are maintained with the dive team at all times.
 - iv. SHALL review the CSRD emergency procedures / SOP's prior to the days training.
 - v. SHALL brief divers on training goals and diver emergency procedures.
 - vi. May consider using the Manikin as a substitute rather than a live casualty.
- (c) Live casualty used who is:
- i. An operational SAR Tech / QL5A SAR Tech Diver.
 - ii. Is familiar with the DTV and its emergency exits / procedures.
 - iii. Wearing a 30 cu/ft pony bottle with ½ mask.

iv. Manikin may be substituted (determined by dive supervisor).

(d) Standby Diver SHALL be:

- i. Dressed at the immediate (CABA).
- ii. Tended (tender briefed by dive supervisor).
- iii. On the surface platform.

(e) SAR Tech 2 Man Dive Team SHALL be:

- i. Dressed as per SOP's for CSRD diving.
- ii. Individually tended from the surface (tenders SHALL be briefed on their duties by the dive supervisor).

(3) In No visibility – Defined as visibility impeded by turbidity where the ability to see is less than 1 metre;

NO CSRD PENETRATION DIVING INTO THE DTV SHALL BE CONDUCTED

(4) If simulating zero visibility to build confidence, i.e. blacked out mask drills, water visibility SHALL be greater than 5 meters; and

(a) The DTV SHALL be positioned offset of the surface platform at a 45 degree angle to allow maximum access to all sides.

(b) Upper hatches will remain open for added interior visibility to the survivor and tending diver.

(c) Manikin only will be used as the casualty for the extraction. If the diver opts to penetrate the DTV.

(d) Supervisor:

- i. SHALL be a SAR Tech Dive Supervisor who has completed the CSRD training and is a current SAR Tech diver / supervisor.
- ii. SHALL only supervise one pair of divers at a time.
- iii. SHALL ensure the headset is monitored and voice communications are maintained with the dive team at all times.
- iv. SHALL review the CSRD emergency procedures / SOP's prior to the days training.
- v. SHALL brief divers on training goals and diver emergency procedures.

(e) Standby Diver SHALL be:

- i. Dressed at the immediate (CABA).
- ii. Tended (tender briefed by dive supervisor).
- iii. On the surface platform.

(f) SAR Tech 2 Man Dive Team SHALL be:

- i. Dressed as per SOP's for CSRD diving.
- ii. Individually tended from the surface (tenders SHALL be briefed on their duties by the dive supervisor).
- iii. Will conduct confidence training dive initially (see training objectives).
- iv. Only penetrating the DTV if comfortable with the confidence training dive.

